

Dart's VSI2 Voltage Signal Isolator Features

The Dart VSI2 (Voltage Signal Isolator) allows for the use of either a grounded or non-grounded remote DC signal such as 0 to 5 through 0 to 250Vdc, 4-20mA current, or a remote speed pot. The DC input signal type can be selected for voltage (Vin) or current (4-20mA) via the JP2 jumper clip. There is a Hi/Lo range jumper (P4) selection that should be set to the (Lo) setting when using a 4-20mA signal or voltage ranges of 0-5 through 0-25Vdc. When using voltage ranges of 0-25 through 0-250 this jumper must be set to (Hi). The GAIN trimpot is used to set full linear output in reference to the input signal range. The output of the VSI2 board is a linear signal that is proportional to the remote input signal being supplied. The VSI2 incorporates a feedback circuit, which virtually eliminates output changes due to the thermal drift of logic components. The VSI2 is packaged in an aluminum chassis mount housing and contains an on-board power supply for its logic circuit, which is powered from 120 VAC or 240 VAC line power. An electrical isolation rating of 2500Vrms is achieved by the use of an optically isolated IC package. The VSI2 requires an AC input to drive the power supply.

Although this isolator was specifically designed to be used with Dart's 500/530B series, it can be used with virtually any speed control that has a speed reference circuit of +5 to +15VDC and an input impedance greater than 47KΩ. The output of the VSI2 is a filtered, pulse width modulated signal that is directly proportional to the input speed signal. The wide input range allows the VSI2 to follow signals as low as +5V logic levels and up to the 180VDC levels present at the armature leads of a 180VDC motor. By simply connecting the input terminals across the armature leads of a "master motor", you can use the VSI2 for master/follower operation. The addition of a scaling pot will provide for proportional follower operation.

Installation Diagram

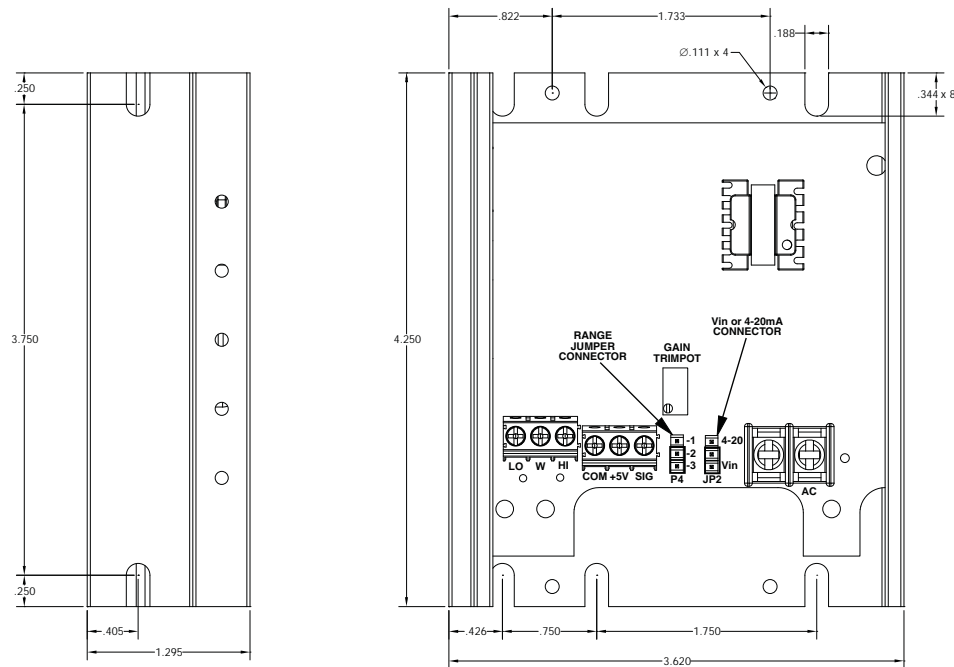

Setup Procedures

1. With NO power to VSI2, connect a DC Voltmeter to control outputs as follows: Meter COMMON to the -ARM terminal, Meter POSITIVE to the +ARM terminal. Select correct meter range (0-90V or 0-180V).
2. Preset GAIN pot on the remote signal board fully CCW.
3. Place the JP2 jumper clip in the proper position based on the input signal being used.
4. Place the P4 jumper clip in the Lo position for 4-20mA signals or voltage signals less than 25Vdc. Place the P4 jumper clip in the Hi position for voltage signals greater than 25Vdc. (NOTE: Never exceed 250Vdc)
5. Make sure all connections are properly made per the hookup connection diagram and then apply AC power to the controller.
6. Set the remote input signal to its lowest setting. Adjust the MIN trimpot to deadband (the point just before an increase causes an output).
7. Apply the maximum remote input signal. Motor should start to run. Adjust the GAIN pot CW until no further increase in control output voltage occurs and then decrease the gain pot slowly until output voltage to the motor drops approximately 5Vdc.
8. Set the MAX trimpot on the VSI2 to the correct motor voltage.
9. Some interaction between trimpots may occur. Recheck the Min trimpot setting and repeat steps 6 through 8 as needed.

VSI2 HOOK-UP CONFIGURATIONS

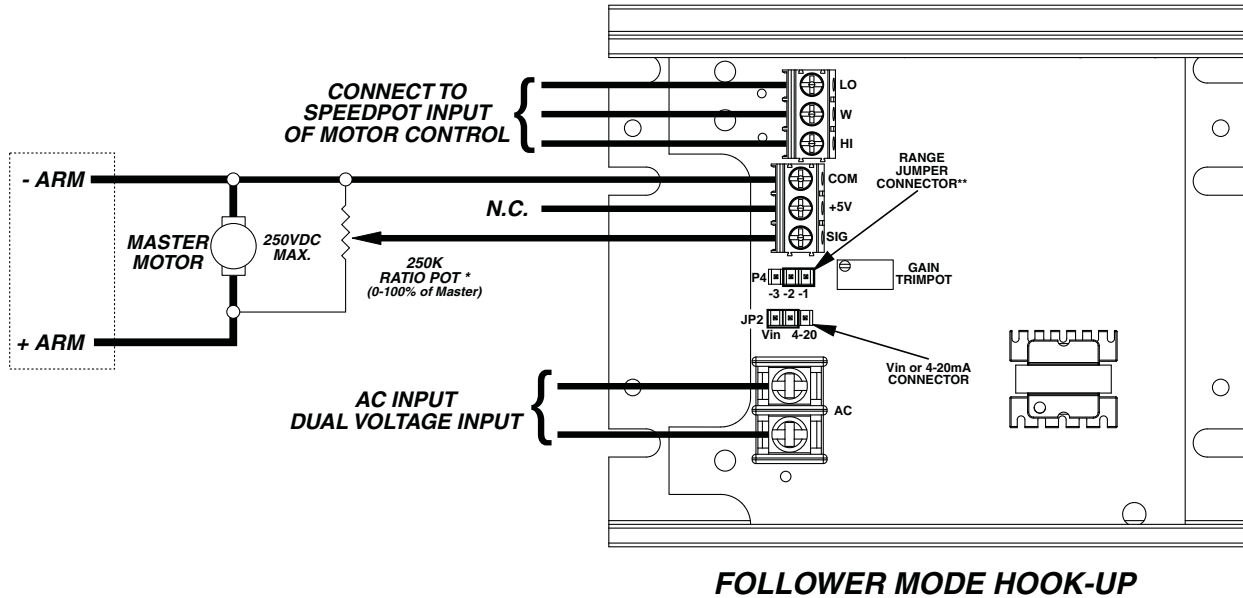
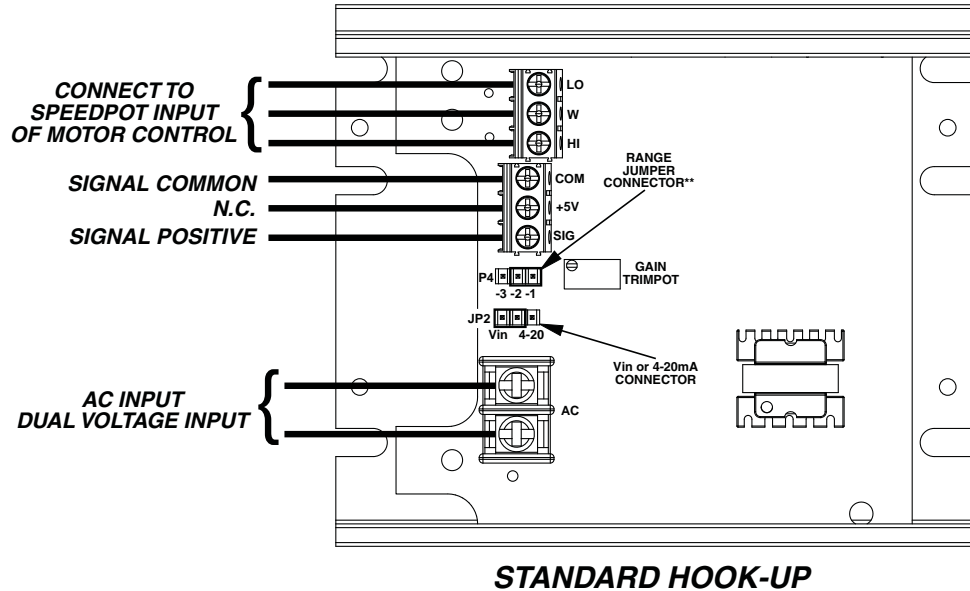

NOTES:

* If ratio of Master is NOT needed, delete the 250K pot and connect +Armature directly to Signal Input.

** Jumper clip is used to select input voltage range. When installed from P4-1 to P4-2, the range is 0-25VDC thru 0-250VDC; when installed from P4-2 to P4-3, range is 0-5VDC thru 0-25VDC.

REPAIR PROCEDURE

In the event that a Product manufactured by Dart Controls Incorporated (DCI) is in need of repair service, it should be shipped, freight paid, to: Dart Controls, Inc., 5000 W. 106th Street, Zionsville, IN. 46077, ATTN: Repair Department. Please include Name, Shipping Address (no P.O. Box), Phone Number and if possible, e-mail address.

Those orders received from anyone without an existing account with DCI must specify if they will be paying COD or Credit Card (Master Card/Visa/American Express). This information is required before work will begin. If you have an account with Dart your order will be processed according to the terms listed on your account. Products with Serial Number date codes over 5 years old will automatically be deemed Beyond Economical Repair (BER). A new, equivalent device will be offered at a substantial discount.

Completed repairs are returned with a Repair Report that states the problem with the control and the possible cause. Repair orders are returned via UPS Ground unless other arrangements are made. If you have further questions regarding repair procedures, contact Dart Controls, Inc. at 317-873-5211.