

DM8000 CONTROL SERIES

DART

CONTROLS

Instruction Manual

**Field Programmable Digital Tachometer
for Rate, Time, and Count**



**5000 W. 106th Street
Zionsville, Indiana 46077**

**Phone (317) 733-2133
Fax (317) 873-1105
www.dartcontrols.com**

Quick Jump

What models and options are available?

See page 3.

Looking for detailed specifications?

See page 3.

Want to get started fast?

See basic electrical hook-up details on page 5.

See mechanical installation details on page 4.

See some sample applications starting on page 21.

Need Help?

See troubleshooting on page 28.

Warranty

Dart Controls, Inc. (DCI) warrants its products to be free from defects in material and workmanship. The exclusive remedy for this warranty is DCI factory replacement of any part or parts of such product which shall within 12 months after delivery to the purchaser be returned to DCI factory with all transportation charges prepaid and which DCI determines to its satisfaction to be defective. This warranty shall not extend to defects in assembly by other than DCI or to any article which has been repaired or altered by other than DCI or to any article which DCI determines has been subjected to improper use. DCI assumes no responsibility for the design characteristics of any unit or its operation in any circuit or assembly. This warranty is in lieu of all other warranties, express or implied; all other liabilities or obligations on the part of DCI, including consequential damages, are hereby expressly excluded.

NOTE: Carefully check the control for shipping damage. Report any damage to the carrier immediately. Do not attempt to operate the drive if visible damage is evident to either the circuit or to the electronic components.

All information contained in this manual is intended to be correct, however information and data in this manual are subject to change without notice. DCI makes no warranty of any kind with regard to this information or data. Further, DCI is not responsible for any omissions or errors or consequential damage caused by the user of the product. DCI reserves the right to make manufacturing changes which may not be included in this manual.

WARNING

Improper installation or operation of this control may cause injury to personnel or control failure. The control must be installed in accordance with local, state, and national safety codes. Make certain that the power supply is disconnected before attempting to service or remove any components!!! If the power disconnect point is out of sight, lock it in disconnected position and tag to prevent unexpected application of power. Only a qualified electrician or service personnel should perform any electrical troubleshooting or maintenance. At no time should circuit continuity be checked by shorting terminals with a screwdriver or other metal device.

Table of Contents

Introduction	2
General Features	2
Models & Options	3
Model Table	3
Available Options.....	3
Recommended Accessories	3
Specifications	3
Electrical	3
Mechanical.....	3
Environmental	4
Mechanical Installation	4
Exploded Panel View.....	4
Cut-out and Mounting Dimensions.....	4
PU-E Series Pickup Installation	5
Electrical Installation & Diagrams	5
P1 Terminal Block Wiring Diagram	5
Dimensions	5
P1 Terminal Block Descriptions	6
-1 Option Wiring	6
Basic Operating Instructions	7
Rate, Time, and Counter Modes Explained	7
Visual Reference.....	7
How to Change a Parameter's Value (The Short Story).....	7
Operating the User Interface (The Long Story)	7
Detailed Configuration Instructions	8
Default Configuration	8
Resetting the Unit to Factory Defaults	8
JP1 (Program Enable Jumper)	8
Software Parameters.....	9
Parameter Descriptions	12
Forward / Reverse - Timing Charts	19
Application Examples	21
Pump Flow Monitor with Audible and Visual Alarm.....	21
Conveyor Oven Time Monitor with Over-Heating Alarm.....	22
Take-up / Pay-out Reel Material Measurement with Alarm.....	23
Bi-directional Incremental Position Display	25
Shared Display Between Two Pickups (Motors)	26
Troubleshooting	28
Technical Support Options	28
What's Special About www.dartcontrols.com ?	28

Introduction

The DM8000 Series Digital Meter is a powerful, microprocessor-based unit capable of being either field or factory configured for a number of today's demanding measurement needs. It can be quickly configured to operate as a digital rate meter, time in process meter, totalizer, zero-speed switch or feature-filled process counter. It also offers up to two alarm outputs which can be adjusted for a number of trigger conditions. Utilizing Dart's modular bus design techniques, the DM8000 is ideal for volume OEM applications requiring specialized inputs and outputs. Contact Dart Controls' Sales Department for details. This flexibility makes the DM8000 ideal for applications such as:

- Pay-out and Take-up Limit Monitors
- Conveyor Oven "Tunnel-Time" Monitors
- Rotating Machinery Tachometers
- Material Measurement Meters

Its durable 1/8DIN aluminum housing can be easily mounted in a panel or control cabinet. New optional pluggable terminal block allows the installer to quickly install or replace units without the hassle of physically removing and reattaching wires. The unit can be ordered with either standard European-style terminal block or optional "pluggable" connector.

General Features

- Microprocessor-based design combines the ultimate in responsiveness and accuracy in one package
- Selectable display update rate
- Capable of measuring shaft speeds lower than 1 RPM @ 1 pulse per revolution
- Large 4 digit, 1/2" LED display
- Factory or field programmable via front-panel keypad
- Lexan membrane and gasket (which are included) meet NEMA 4X standards when used with NEMA 4X enclosures
- Internal program-enable jumper selectively prevents tampering with unit's configuration
- European terminal block or pluggable terminal block available
- Universal power supply accepts line voltages inputs from 85-250VAC @ 50-60Hz without switches or jumpers.

The unit automatically adjusts as needed.

- Non-volatile memory stores adjustable parameters even when power has been removed
- Compatible with a variety of signal input types including: Hall-Effect Pickups, Photoelectric, TTL, etc.

Note: Open collector devices must be capable of sinking 3mA.

- Wide operating ambient temperature range of -10C to 45C (14F to 113F)
- Self-contained power supply for external sensor, limited to 5V @ 50mA
- Up to 2 programmable alarm outputs with Form C contacts rated to 250VAC @ 5A
- Multiple auto-ranging features allow the user to view display values from 0.001 to 99,990 in any user-defined unit. (GPH, MPH, RPM, etc.)
- Multiple operating modes including:
 - Rate Mode – Displays in rate unit such as RPM, Gallons per Second, etc.
 - Time Mode – Displays in time unit such as HH:MM, MM:SS, SS:TT, or other unit
 - Counter Modes – Displays resettable and reloadable counter value which can optionally increment or decrement for each input pulse. Quadrature inputs can automatically be translated to up/down counts for bidirectional applications.
 - Rate Mode with Direction indicator – Displays in rate unit such as RPM, Gallons per Second, etc, also indicates which direction the pick-up is truing.
 - Time Mode with Direction indicator – Displays in time unit such as HH:MM, MM:SS, SS:TT, or other unit also indicates which direction the pick-up is truing.
 - Dual Rate Mode – Displays in rate unit such as RPM, Gallons per Second, etc, of two inputs.
 - Dual Time – Displays in time unit such as HH:MM, MM:SS, SS:TT, or other unit of two inputs.

Models & Options

Model Table

Model	Input Voltage	Alarm Outputs	Measures Rate?	Measures Time?	Up Counter?	Down Counter?	Quadrature Encoder Compatible?
DM8000	85-250VAC	1	Yes	Yes	Yes	Yes	Yes

Available Options

Option Suffix	Description	Example
-1	Expansion board which adds support for remote push button wiring via a European style terminal block.	DM8000-1
-P	Optional pluggable terminal block	DM8000-P
-R	Optional second isolated alarm output relay (250VAC @ 5A)	DM8000-R, DM8000-1-R

Recommended Accessories

Model	Description	Pulses per Revolution	RPM Range When Used With DM8000 Series
PU-2E / PU-2R*	Hall-Effect Pickup, Single Channel	1	1.0 – 100,000 RPM
PU-4E / PU-4R*	Hall-Effect Pickup, Single Channel	2	0.5 – 50,000 RPM
PU-20E / PU-20R*	Hall-Effect Pickup, Single Channel	10	0.1 – 10,000 RPM
PU-40E / PU-40R*	Hall-Effect Pickup, Single Channel	20	0.05 – 5,000 RPM

* "R" indicates outdoor duty version.

Specifications

Electrical

Line Input Voltage	Any Voltage from 85-250 VAC
Line Input Frequency	Any Freq. from 48-62 Hertz
Signal Input Frequency Range	0 – 100,000 Pulses per Minute (Higher frequencies are possible when using internal frequency divisor)
Display Range	0.001 – 99,999
Units of Operation	User Programmable, any Unit
Sensor / Pickup Power Supply	5V @ 50mA
Isolated Alarm Relay Output Ratings	250VAC @ 5A

Mechanical

Display Type	LED, Red, 4 Digit, ½" Height
Housing Type (with supplied gasket in NEMA 4X panel)	NEMA 4X
Connector Style (pluggable connector optional)	12-position 5mm European Style
Terminal Block Torque Setting	4.4 in. lb. Max or .5Nm
Faceplate Material	Polycarbonate with GE Lexan Overlay
Housing Material	Aluminum
Length (Panel Depth)	4.63", 117.5mm
Width	4.54", 115.3mm
Weight	.84 lb, 13.5 oz, 382g

Environmental

Operating Temperature Range-----10C to 45C (15F to 115F)

Operating Humidity Range----- 95%, non-condensing

Mechanical Installation

Exploded Panel View

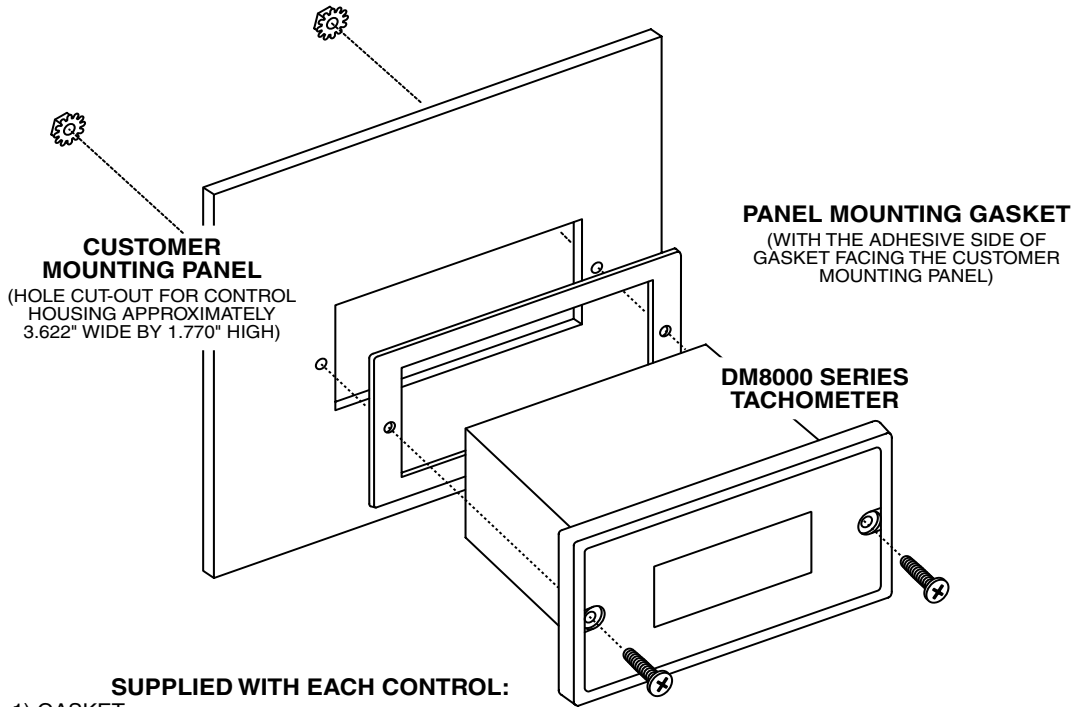

SUPPLIED WITH EACH CONTROL:

- 1) GASKET
- 2) (2) 6-32 X 3/4 PANHEAD BLACK OXIDE STAINLESS SCREWS
- 3) (2) #6 NUT WITH LOCKWASHER

Cut-out and Mounting Dimensions

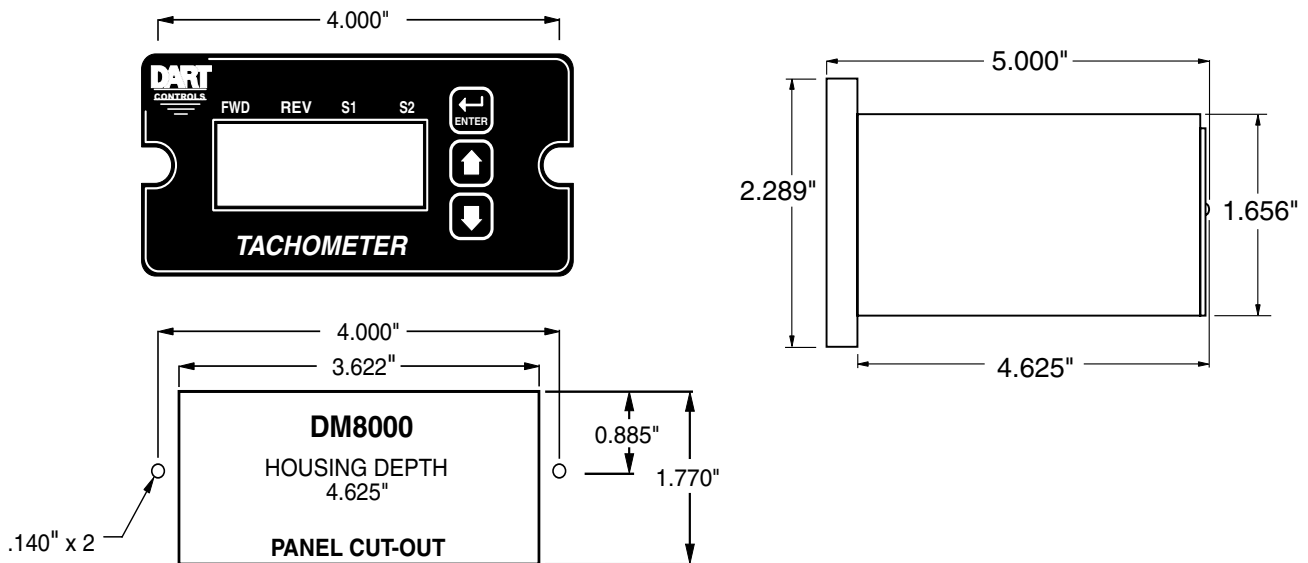

PU Series Pickup Installation

The PU series pickup is an economical way to monitor motor speed. Its patented design provides for ease of installation in otherwise difficult to reach areas. The PU operates from a +5V power supply, producing a 5 volt square wave whose frequency is proportional to speed. This signal is fed into the DM8000 control as a speed or position reference for the microprocessor.

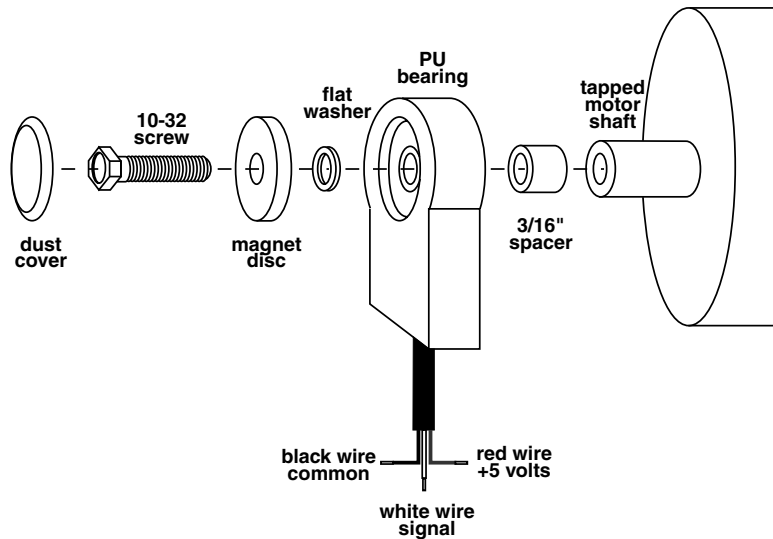

Model Number	Pulses per Revolution
PU-2E / PU-2R	1
PU-4E / PU-4R	2
PU-20E / PU-20R	10
PU-40E / PU-40R	20

Dimensions

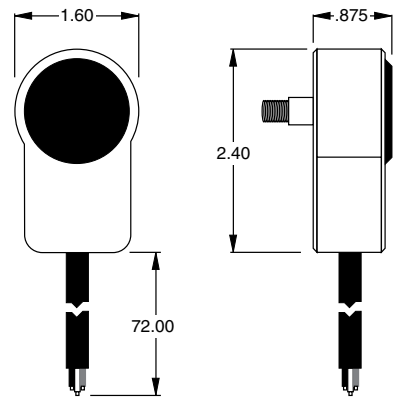

No other mounting screws are necessary, as the cord will keep the unit from rotating.

Caution: The PU cord should not be grouped with other wires or cords. For applications with PU wire over 6 feet long, or noisy environments, a shielded cable is recommended. Connect the shield to the common terminal on the DM8000, leaving the shield on the PU end floating.

Electrical Installation & Diagrams

P1 Terminal Block Wiring Diagram

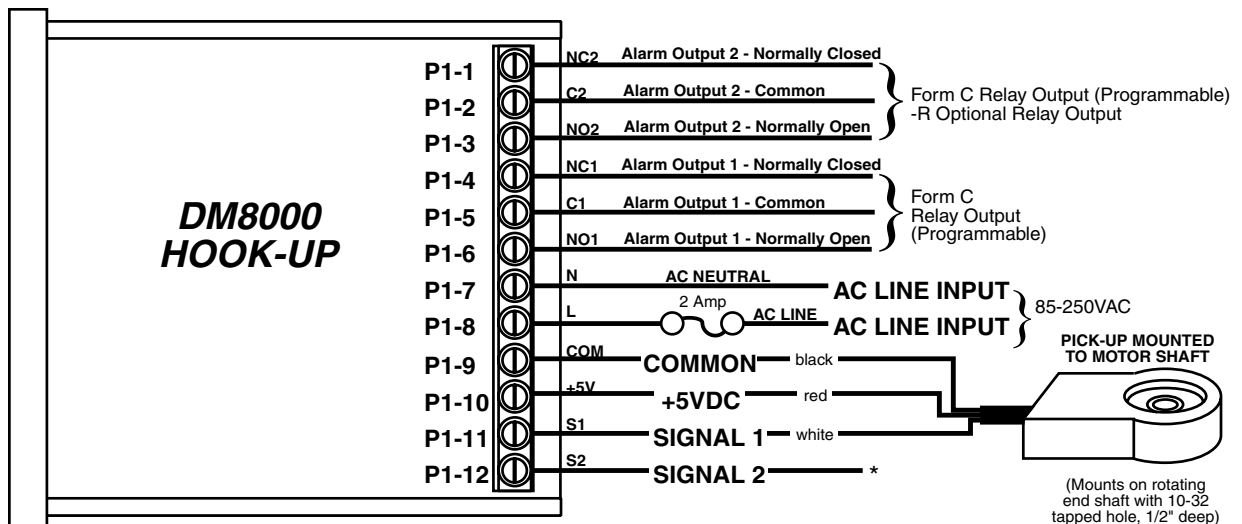

* Used for various functions, including quadrature counter mode.

P1 Terminal Block Descriptions

- P1-1 (2NC) – This is the normally-closed contact of the second user assignable relay output. This terminal is active only on units ordered with the -R option.
- P1-2 (2C) – This is the common contact of the second user assignable relay. This terminal is active only on units ordered with the -R option.
- P1-3 (2NO) – This is the normally-open contact of the second user assignable relay output. This terminal is active only on units ordered with the -R option.
- P1-4 (1NC) – This is the normally-closed contact of the first user assignable relay output.
- P1-5 (1C) – This is the common contact of the first user assignable relay.
- P1-6 (1NO) – This is the normally-open contact of the first user assignable relay output.
- P1-7 (AC / N) – For single phase AC lines connect the Neutral side of your AC line to this terminal. For systems with two hot AC lines, connect either of the Hot AC lines to this terminal.
- P1-8 (AC / L) – For single phase AC lines connect the Hot side of your AC line to this terminal. For systems with two hot AC lines, connect either of the Hot AC lines to this terminal.
- P1-9 (COM) – This is the common point for the control logic. The speed sensor common lead as well as any other source needing to reference the control common will be connected to this terminal.
- P1-10 (+5V) – This is a self-contained +5VDC power supply capable of up to 50mA. The speed sensor supply lead can be connected to this terminal for its power source.
- P1-11 (S1) – This is the Signal input terminal for single channel operation or channel 1 of dual channel operation. The signal lead of your speed or counter sensor will be connected here.
- P1-12 (S2) – This is the Signal input terminal for channel 2 during dual channel operation. The second signal lead of the speed or position sensor should be connected here. This terminal is also used as a reset input or function change input for various operations of the control. In counter modes, this input may also be used as a counter reset or enable gate.

-1 Option Wiring

The -1 option board is a module which allows external up and down push buttons to be wired to the unit. These buttons operate exactly like the Up and Down buttons on the user interface. This module is commonly used to allow PLCs or hand-held pendants to operate the front-panel remotely. Wire for the external buttons are attached via a 3mm European terminal block on the -1 option board. The buttons are activated by shorting the terminal labeled Com to either the Up or Down terminal.

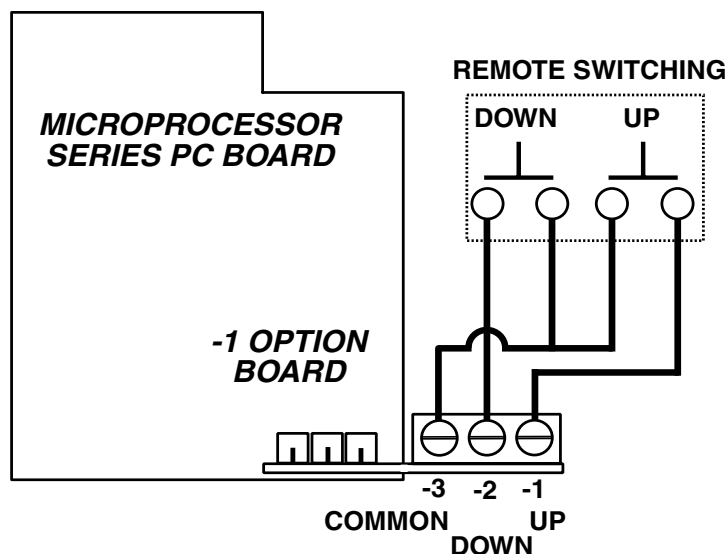

Basic Operating Instructions

Rate, Time, and Counter Modes Explained

In Rate Mode, the DM8000 measures the input frequency, converts it to the user-defined units, and displays the rate in the display window of the user interface. Most applications utilize rate mode and display in units such as gallons-per-minute, feet-per-second, and RPM.

In Time Mode, the DM8000 measures the input frequency, converts it to the user-defined time units, and displays the time in the display window. This mode is most-commonly used in time-sensitive processes such as conveyor ovens and plating applications.

In Counter Modes, the DM8000 counts each incoming pulse, scales it per the user-defined ratios, and displays the count in the display window. Typical counting applications include linear material measurement, cycle counters, and liquid volume measurement.

In Rate or Time with Direction modes a quadrature pick-up is required. In these modes it will perform the same functions as above under Rate or Time modes but the FWD and REV annunciators will be used to indicate the direction that the pick-up is turning. Please refer to the FORWARD / REVERSE - TIMING CHARTS for more information on the timing of the quadrature pick-up.

In Dual Rate or Dual Time modes two signals are needed, one on S1 and one on S2. In these modes it will perform the same functions as above under Rate or Time modes but the S1 and S2 annunciators will be used to indicate which signal is being viewed. In order to switch between the two signals the Up and Down buttons are used; Down for S1 and Up for S2.

Visual Reference

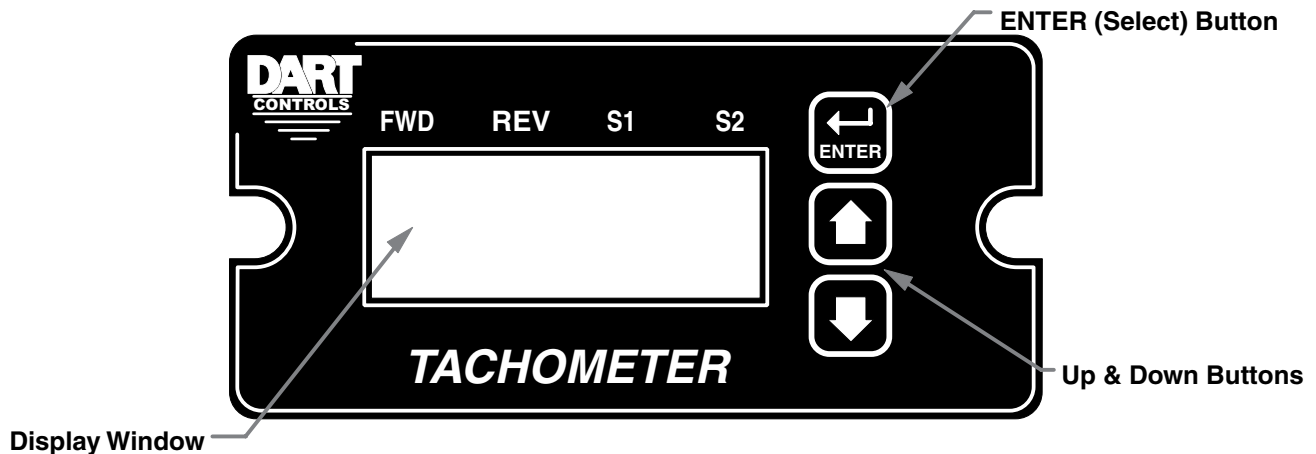

How to Change a Parameter's Value (The Short Story)

1. Hold down the Enter button until Parameter-Selection Mode is entered
2. Using the Up and Down buttons, select the desired parameter number to view or edit
3. Press the Enter button to change the value of the parameter
4. Using the Up and Down buttons, change the parameter's value as desired
5. Press the Enter button to permanently save the changes (Return to Parameter-Selection Mode)
6. Select parameter zero and press the Enter button to return to Running Mode

Operating the User Interface (The Long Story)

Although the DM8000 user interface is very versatile, it is also simple to setup and operate. With just a few button presses, it allows the user to configure a number of adjustable parameters. The LED display has three basic operating modes: Running Mode, Parameter-Selection Mode, and Value Mode. Each of the three modes have specific visual indicators that allow the user to immediately determine the current state or mode of the user interface. Parameter-Selection Mode and Value Mode can only be entered if the Program Enable jumper is in the "On" position.

Rate Mode is the default display of the unit when power is applied. The DM8000 will spend the majority of its time in this mode. In Rate Mode, the display shows the measured value in the appropriate user-defined format of rate, time, or count. As the input signal changes, the display is continuously updated to show the latest measurement. In this display mode, the Up and Down buttons serve no function other than to reset or silence alarms if configured accordingly. Example displays for rate, time, and count operating modes are 13.60, 45:30, and 9301.

Parameter-Selection Mode can be entered by simply pressing and holding the Enter button down for three seconds. Once in Parameter-Selection Mode, the far left of the display will be a 'P'. The right side of the display will indicate the currently selected parameter number for editing purposes. Pressing the Up or Down button will increase or decrease the selected parameter number on the display. Although the parameter numbers are in numerical order, some numbers are skipped. These numbers represent reserved parameters that are not yet implemented and are not displayed. Once the desired parameter number is displayed, a press of the Enter button will change the display to the Value Mode. When in Parameter-Selection Mode, pressing the Enter button with parameter 0 selected will cause the unit to return to Running Mode. Example displays for Parameter-Selection Mode are P 1, P 12, and P 54. See the Software Parameters for a list of available parameters.

Value Mode is used to modify the value of the selected parameter. When in Value Mode, the two dots which form the colon, between digits two and three, will alternately flash (one, then the other) to inform the user that a parameter's value is being edited. Pressing the Up or Down button increases or decreases the selected parameter's value. See the Software Parameters for a list of allowable values and ranges. Value changes take effect immediately. For example, when scrolling through the alarm output conditions, the relay will activate as the always-active selection is passed. Once the desired value is showing in the display window, pressing the Enter button again will return to Parameter-Selection Mode. The new value is not saved in permanent memory until the Enter button is pressed. Removing power from the unit while in Value Mode may result in the specified new value being lost.

Detailed Configuration Instructions

Default Configuration

When shipped from the factory, the following basic settings are in place:

Rate Mode Operation in RPM

S1 Signal Input Pulses-per-Revolution: 1

Decimal Point Display: Off

Auto-Ranging: Disabled

Alarm Output(s): Disabled

Resetting the Unit to Factory Defaults

The factory-default settings can be easily restored using either of two methods. Both methods require the Program Enable jumper to be in the "On" position. The first is to apply power to the unit with both the Enter and Down buttons pressed for 3 seconds. The second is to change the value of parameter 95 to 5.

JP1 (Program Enable Jumper)

The JP1 jumper is located under the dust cover on the back end of the upper board. When the jumper is set to the "Off" position, all programming features are locked out to the front panel user. When the jumper is in the "On" position, the programming parameters are open to change. JP1 is shipped from the factory set in the "On" position.

Software Parameters

Parameter	Description	Value Range (units)	Factory Default	User Settings
0	Selecting this item exits to Running Mode	n/a	n/a	
Read-Only Parameters				
1	Model Number	n/a	80	
2	Software Build	1 – 9999	n/a	
3	Hardware Version	1 – 9999	n/a	
4	Serial Number – Major (reserved)	n/a	n/a	
5	Serial Number – Minor (reserved)	n/a	n/a	
General Setup				
10	Operating Mode	1 – Rate Mode 2 – Time Mode 3 – Up Counter 4 – Down Counter 5 – Up / Down Counter 6 – Rate Mode with Direction 7 – Time Mode with Direction 8 – Dual Rate Mode 9 – Dual Time Mode	1	
11	Display Intensity	0 – 31 (Dim – Bright)	20	
14	Input Trigger / Prescaler Setup	1 - Every Rising Edge 2 – Every Falling Edge 3 – Falling Edge / 4 4 – Falling Edge / 16	1	
16	Counter Mode Reset Configuration	1 – Reset Disabled 2 – Reset on Keypress 3 – Reset on S2 Low 4 – Reset on S2 High	1	
Signal Input #1 (S1) Setup				
20	Display Reference	1 – 9999 (Display Units)	1000	
21	Reference RPM	1 – 9999 (RPM)	1000	
22	Pulses Per Revolution	1 – 9999 (PPR)	1	
23	Recovery Rate	0 – 1000 (1/2 seconds) 0 – Disabled > 0 – Recovery 1/2 seconds	10	
24	Display Smoothing / Averaging	0 – 60 (seconds) 0 – Disabled > 0 – Averaging Seconds	1	
25	Decimal Point Position	0 – DP Disabled (XXXX) 1 – X.XXX 2 – XX.XX 3 – XXX.X 4 – XXXX.	0	
26	Auto-Ranging Configuration	0 – Auto-Ranging Off 1 – Auto-Range on Overflow 2 – Auto-Ranging On	0	
27	Counter Mode Reset / Preload Value	0 – 9999 (counts)	0	
Signal Input #2 (S2) Setup				
30	Display Reference	1 – 9999 (Display Units)	1000	
31	Reference RPM	1 – 9999 (RPM)	1000	
32	Pulses Per Revolution	1 – 9999 (PPR)	1	

Software Parameters, cont'd

Parameter	Description	Value Range (units)	Factory Default	User Settings
33	Recovery Rate	0 – 1000 (½ seconds) 0 – Disabled > 0 – Recovery ½ seconds	10	
34	Display Smoothing / Averaging	0 - 60 (Seconds) 0 – Disabled > 0 – Averaging Seconds	1	
35	Decimal Point Position	0 – DP Disabled (XXXX) 1 – X.XXX 2 – XX.XX 3 – XXX.X 4 – XXXX.	0	
36	Auto-Ranging Configuration	0 – Auto-Ranging Off 1 – Auto-Ranging on Overflow 2 – Auto-Ranging On	0	
37	Counter Gate Configuration	1 – Disabled 2 – Counting Enabled (Low) 3 – Counting Enabled (High)	1	
Alarm Output #1 Configuration				
40	Activation Conditions	0 – Always Off 1 – Always On 2 – Active when S1 Above Limit 3 – Active when S1 Below Limit 4 – Active when S1 inside Range 5 – Active when S1 outside Range 6 – Active when S2 Above Limit 7 – Active when S2 Below Limit 8 – Active when S2 inside Range 9 – Active when S2 outside Range	0	
41	Output Style & Reset Mode	1 – Constant & Auto Reset 2 – Constant & Manual Reset 3 – Pulsed & Auto Reset 4 – Pulsed & Manual Reset	1	
42	Reset Configuration	1 – No Sil., Reset on Key 2 – No Sil., Reset on S2 High 3 – No Sil., Reset on S2 Low 4 – Sil., Reset on Key 5 – Sil., Reset on S2 High 6 – Sil., Reset on S2 Low	1	
43	Display Flash On Active Alarm	0 – Alarm Flash Disabled 1 – Alarm Flash Enabled	0	
44	Pulse on Time	1 – 3600 (seconds)	1	
45	Pulse off Time	1 – 3600 (seconds)	1	
46	Pulse Count	0 – 9999 (pulses)	0	
47	Lower Limit	0 – 9999 (display units)	0	
48	Upper Limit	0 – 9999 (display units)	9999	
Alarm Output #2 Configuration				
50	Activation Conditions	0 – Always Off 1 – Always On 2 – Active when S1 Above Limit 3 – Active when S1 Below Limit 4 – Active when S1 inside Range 5 – Active when S1 outside Range 6 – Active when S2 Above Limit 7 – Active when S2 Below Limit 8 – Active when S2 inside Range 9 – Active when S2 outside Range	0	

Software Parameters, cont'd

Parameter	Description	Value Range (units)	Factory Default	User Settings
51	Output Style	1 – Constant & Auto Reset 2 – Constant & Manual Reset 3 – Pulsed & Auto Reset 4 – Pulsed & Manual Reset	1	
52	Reset Configuration	1 – No Sil., Reset on Key 2 – No Sil., Reset on S2 High 3 – No Sil., Reset on S2 Low 4 – Sil., Reset on Key 5 – Sil., Reset on S2 High 6 – Sil., Reset on S2 Low	1	
53	Display Flash On Active Alarm	0 – Alarm Flash Disabled 1 – Alarm Flash Enabled	0	
54	Pulse On Time	1 – 3600 (seconds)	1	
55	Pulse Off Time	1 – 3600 (seconds)	1	
56	Pulse Count	0 – 9999 (pulses)	0	
57	Lower Limit	0 – 9999 (display units)	0	
58	Upper Limit	0 – 9999 (display units)	9999	
	Parameter Memory Commands			
95	Restore Settings to Factory Default	0 – Do Nothing & Exit 5 – Restore Factory Defaults	0	
98	Save to User Default Area	0 – Do Nothing & Exit 5 – Save Setting	0	
99	Restore from User Default Area	0 – Do Nothing & Exit 1 – Restore Settings	0	

Parameter Descriptions

Parameter 0 – Exit to Running Mode

When parameter 0 is selected in Parameter-Selection Mode, the unit will return to Running Mode and display the running value. This should be selected once changes to parameters are completed.

Parameter 1 – Model Number (Read Only)

This is a number which represents the base model number for the product. For the DM8000 Series, the model code is 80.

Parameter 2 – Software Build (Read Only)

The software build is a code which identifies the software version of the unit.

Parameter 3 – Hardware Version (Read Only)

The hardware version is a code which identifies which hardware was used to build the unit.

Parameter 4 & 5 – Serial Number, Major & Minor (Read Only)

These parameters are reserved for future use as an electronic serial number and are unique to each manufactured unit.

Parameter 10 – Operating Mode

This parameter defines the basic mode of operation for the entire unit. It determines if the unit is measuring rate, time, or count information. The following modes are available for the DM8000:

Mode 1 – Rate Mode

Rate mode displays measurements in rate units such as RPM, Gallons per Hour, or Feet per Second.

Mode 2 – Time Mode

Time mode displays measurements in time units using the format AA:BB. By default AA:BB represents minutes (AA) and seconds (BB). Optionally, it can be configured to represent hours (AA) and minutes (BB) or other user-defined units with a 1:60 relationship.

Mode 3 – Up Counter

Counter modes (3 – 5), display measurements in pulse counts or user-defined units which are proportional to pulse count. In these modes, the DM8000 will count the pulses which are applied to the S1 input and display the related value. In this mode, each input pulse increments the counter. **NOTE:** When in Count Mode, Parameter 23 needs to be set to zero.

Mode 4 – Down Counter

Same as Mode 3 above except each input pulse decrements the counter.

Mode 5 – Up / Down Counter

Same as Mode 3 above except each input pulse either increments or decrements the counter depending upon the state of Signal Input #2 (S2). If S2 is tied to common, the counter is incremented; otherwise, it is decremented.

Mode 6 – Rate Mode with Direction

Same as Mode 1 with annunciators indicating direction of travel. See Forward/Reverse Timing Charts Section for further details. *Note: a quadrature pickup must be used.*

Mode 7 – Time Mode with Direction

Same as Mode 2 with annunciators indicating direction of travel. See Forward/Reverse Timing Charts Section for further details. *Note: a quadrature pickup must be used.*

Mode 8 – Dual Rate Mode

Same as Mode 1, except monitoring two rate inputs using up and down arrow to toggle between the two.

Mode 9 - Dual Time Mode

Same as Mode 2, except monitoring two time inputs using up and down arrow to toggle between the two.

Parameter 11 – Display Intensity

This parameter adjusts the intensity of the LED display digits in the front panel of the unit. The values of 0 – 31 correspond to a gradual change from very dim to very bright. This is often useful when the DM8000 is used in the same panel as other pieces of equipment with LED displays and a uniform display brightness is desired. Simply adjust the DM8000 to match its surroundings.

Parameter 14 – Input Triggers / Prescale

This parameter determines how the DM8000 processes the S1 signal input. It specifies which signal edge is used for the measurements and the value of the internal frequency divider or prescaler. Modes 3 and 4 should only be used if the input pulse rate exceeds the unit's maximum native pulse rate (see specifications for details); otherwise, timing and counting calculations may become sluggish and unnecessarily inaccurate.

Mode 1: Every Rising Edge, No Prescaler

In this mode, the signal input is measured at every rising edge.

Mode 2: Every Falling Edge, No Prescaler

In this mode, the signal input is measured at every falling edge.

Mode 3: Falling Edge, Prescaler = 4

In this mode, the signal input is measured at every 4th falling edge. This mode is especially useful when the signal input frequency is beyond the native pulse-per-minute range of the DM8000. Because unit will automatically compensate for the prescaler, there is no need to factor in the prescaler value when setting the Display and RPM Reference parameters.

Mode 4: Falling Edge, Prescaler = 16

Same as Mode 3 except the signal input is only measures every 16th falling edge.

Parameter 16 – Counter Reset Configuration

In counter applications, it is often desirable to have the user or an external signal reset the counter value to zero or some predetermined value. This parameter specifies which actions will cause the counter to reset to the Counter Reset / Preset Value, parameter 27.

Mode 1: Reset Disabled

The counter cannot be reset.

Mode 2: Reset On Button Press

The counter will reset to the Counter Reset / Preset Value, parameter 27, when any of the user-interface buttons are depressed.

Mode 3: Reset On S2 Input Low (Wired To Common)

The counter will reset to the Counter Reset / Preset Value, parameter 27, when S2 (signal 2) is brought to an electrically low state or wired to the unit's common.

Mode 4: Reset On S2 Input High (Not Wired To Common)

The counter will reset to the Counter Reset / Preset Value, parameter 27, when S2 (signal 2) is brought to an electrically high state (+5V) or left to float disconnected from the unit's common.

Parameter 20 – Signal Input 1 (S1) Display Reference

This is the number to be displayed when at the user-specified motor Reference RPM. In Rate Mode, this value represents the numerator of the rate unit such as feet, ounces, or revolutions. In Time Mode, this value represents the reference time measured in seconds or minutes. If the desired display is HH:MM, then all values should be entered in minutes. If MM:SS is desired, then all values should be entered in seconds. In Counter Modes, this value is the reference count ratio which corresponds to the number of counts which equate to the specified number of reference pulses, parameter 21. See applications for examples.

Parameter 21 – Signal Input 1 (S1) Reference RPM (Reference Pulses in Counter Modes)

This is the reference RPM at which the Display Reference value should be displayed. In Rate and Time Modes, this value represents the RPM of the encoder to which the Display Reference corresponds. In Counter Modes, this value is the Reference Pulses which correspond to the specified number of displayed counter, parameter 21. See applications for examples.

Parameter 22 – Signal Input 1 (S1) Pulses per Revolution

This is the number of pulses per revolution. Value may be from 1 to 9999.

Parameter 23 – Signal Input 1 (S1) Recovery Rate

This is the rate at which the display will attempt to recover once the pulse train appears to have stopped. The recovery rate is the number of half seconds which the unit will wait before dividing (Rate Mode) or multiplying (Time Mode) the display value by 2 in an attempt to accurately represent the current speed or time. In the absence of input pulses, this will continue at regular intervals until either 0 (Rate Mode) or 99:99 (Time Mode) is reached. Setting this parameter to 0 will disable the automatic recovery feature. If this parameter is set too low for the application, the division or multiplication may prematurely occur causing the reading to read too high, too low, or unstable. This can easily be corrected by simply increasing this parameter's value or disabling it by setting it to zero. **Note:** When in Count Mode, this parameter needs to be set to zero.

Parameter 24 – Signal Input 1 (S1) Display Smoothing / Averaging

This is the amount of time, in 1-second increments, which will be averaged before updating the display. Setting this parameter to 0 will disable the averaging feature.

Parameter 25 – Signal Input 1 (S1) Decimal Point (DP) Position

This selects the format of the display with respect to the decimal point's position. This parameter does not effect the value entry for other parameters. For example, if the user desires to display 10.00 at an input of 300RPM, then parameter 20 would be set to 1000, parameter 21 would be set to 300, and parameter 25 would be set to 2.

Mode 0: Fixed XXXX

Mode 1: Fixed X.XXX

Mode 2: Fixed XX.XX

Mode 3: Fixed XXX.X

Mode 4: Fixed XXXX.

Parameter 26 – Signal Input 1 (S1) Auto-Ranging Configuration

This selects how the unit auto-ranges and formats the numbers for the display.

Mode 0: Auto-Ranging Disabled

The auto-ranging mode is disabled. Ignoring decimal points, this limits the units display range from 0 to 9999. Values beyond this range will display as an overflow error (-OF-).

Mode 1: Auto-Ranging On Overflow Only

In this mode, auto-ranging will only be activated if the display value exceeds the maximum native display value. For example, in XX.XX decimal point mode, 99.99 would be the maximum native value for a 4-digit display. When the display is in overflow, it will display only the 4 most significant digits and the decimal point will flash.

Mode 2: Auto-Ranging Always Active

In this mode, auto-ranging is always active and continuously attempts to display the 4 most significant digits. For example, the display will automatically range from 0.001 to 9999 as needed. In this mode, any value over 9999 will be displayed as an overflow error (-OF-).

Parameter 27 – Counter Reset / Preset Value

This is the value that will automatically be loaded into the display after the counter has been reset. See Counter Reset Configuration, parameter 16, for more details.

Parameter 30 – Signal Input 2 (S2) Display Reference

This is the number to be displayed when at the user-specified motor Reference RPM. In Rate Mode, this value represents the numerator of the rate unit such as feet, ounces, or revolutions. In Time Mode, this value represents the reference time measured in seconds or minutes. If the desired display is HH:MM, then all values should be entered in minutes. If MM:SS is desired, then all values should be entered in seconds. In Counter Modes, this value is the reference count ratio which corresponds to the number of counts which equate to the specified number of reference pulses, parameter 21. See applications for examples.

Parameter 31 – Signal Input 2 (S2) Reference RPM (Reference Pulses in Counter Modes)

This is the reference RPM at which the Display Reference value should be displayed. In Rate and Time Modes, this value represents the RPM of the encoder to which the Display Reference corresponds. In Counter Modes, this value is the Reference Pulses which correspond to the specified number of displayed counter, parameter 21. See applications for examples.

Parameter 32 – Signal Input 2 (S2) Pulses per Revolution

This is the number of pulses per revolution. Value may be from 1 to 9999.

Parameter 33 – Signal Input 2 (S2) Recovery Rate

This is the rate at which the display will attempt to recover once the pulse train appears to have stopped. The recovery rate is the number of half seconds which the unit will wait before dividing (Rate Mode) or multiplying (Time Mode) the display value by 2 in an attempt to accurately represent the current speed or time. In the absence of input pulses, this will continue at regular intervals until either 0 (Rate Mode) or 99:99 (Time Mode) is reached. Setting this parameter to 0 will disable the automatic recovery feature. If this parameter is set too low for the application, the division or multiplication may prematurely occur causing the reading to read too high, too low, or unstable. This can easily be corrected by simply increasing this parameter's value or disabling it by setting it to zero. **Note:** When in Count Mode, this parameter needs to be set to zero.

Parameter 34 – Signal Input 2 (S2) Display Smoothing / Averaging

This is the amount of time, in 1-second increments, which will be averaged before updating the display. Setting this parameter to 0 will disable the averaging feature.

Parameter 35 – Signal Input 2 (S2) Decimal Point (DP) Position

This selects the format of the display with respect to the decimal point's position. This parameter does not effect the value entry for other parameters. For example, if the user desires to display 10.00 at an input of 300RPM, then parameter 20 would be set to 1000, parameter 21 would be set to 300, and parameter 25 would be set to 2.

Mode 0: Fixed XXXX

Mode 1: Fixed X.XXX

Mode 2: Fixed XX.XX

Mode 3: Fixed XXX.X

Mode 4: Fixed XXXX.

Parameter 36 – Signal Input 2 (S2) Auto-Ranging Configuration

This selects how the unit auto-ranges and formats the numbers for the display.

Mode 0: Auto-Ranging Disabled

The auto-ranging mode is disabled. Ignoring decimal points, this limits the units display range from 0 to 9999. Values beyond this range will display as an overflow error (-OF-).

Mode 1: Auto-Ranging On Overflow Only

In this mode, auto-ranging will only be activated if the display value exceeds the maximum native display value. For example, in XX.XX decimal point mode, 99.99 would be the maximum native value for a 4-digit display. When the display is in overflow, it will display only the 4 most significant digits and the decimal point will flash.

Mode 2: Auto-Ranging Always Active

In this mode, auto-ranging is always active and continuously attempts to display the 4 most significant digits. For example, the display will automatically range from 0.001 to 9999 as needed. In this mode, any value over 9999 will be displayed as an overflow error (-OF-).

Parameter 37 – Signal Input 2 (S2) Counter Gate (Enable / Disable) Configuration

This selects how the S2 input is utilized in single channel counter modes.

Mode 1: Disabled (Required For Up / Down Counter Mode)

The S2 input will not function as a gate control and instead will act as the second input for dual-channel counter operation.

Mode 2: Counting Enabled When S2 Input Low (Wired To Common)

The unit will continue to count input pulses as long as the S2 is in an electrically low state or connected to the unit's common terminal. When the S2 input goes high (+5V) or is allowed to float disconnected, the counter will be frozen at its current value.

Mode 3: Counting Enabled When S2 Input High (Not Wired To Common)

The unit will continue to count input pulses as long as the S2 is in an electrically high (+5V) state or allowed to float disconnected. When the S2 input goes low or is wired to the unit's common, the counter will be frozen at its current value.

Parameter 40 & 50 – Alarm 1 & 2 Conditions

This defines which conditions will result in the alarm 1 or alarm 2 outputs being activated.

Mode 0: Always Inactive

The alarm output will remain in an inactive state. In this state, the NC and C contacts will be internally electrically connected.

Mode 1: Always Active (When Power Is Applied)

The alarm output will become active when the power is applied to the unit. In this state, the NO and C contacts will be internally electrically connected.

Mode 2: Active When Signal Input 1 (S1) Display Value Above Limit

The alarm output will activate when the displayed value is above the upper limit settings, parameters 48 and 58 accordingly.

Mode 3: Active When Signal Input 1 (S1) Display Value Below Limit

The alarm output will activate when the displayed value is below the lower limit settings, parameters 47 and 57 accordingly.

Mode 4: Active When Signal Input 1 (S1) Display Value Inside Range

The alarm output will activate when the displayed value is greater than or equal to lower limit settings and less than or equal to the upper limit setting.

Mode 5: Active When Signal Input 1 (S1) Display Value Outside Range

The alarm output will activate when the displayed value is less than the lower limit setting or greater than upper limit setting.

Mode 6: Active When Signal Input 2 (S2) Value Above Limit

The alarm output will activate when the displayed value is above the upper limit settings, parameters 48 and 58 accordingly.

Mode 7: Active When Signal Input 2 (S2) Value Below Limit

The alarm output will activate when the displayed value is below the lower limit settings, parameters 47 and 57 accordingly.

Mode 8: Active When Signal Input 2 (S2) Value Inside Range

The alarm output will activate when the displayed value is greater than or equal to lower limit settings and less than or equal to the upper limit setting.

Mode 9: Active When Signal Input 2 (S2) Value Outside Range

The alarm output will activate when the displayed value is less than the lower limit setting or greater than upper limit setting.

Parameter 41 & 51 – Alarm 1 & 2 Output Style & Reset Configuration

This setting configures the output mode and reset method for the alarm outputs.

Mode 1: Constant & Auto Reset

In this mode, the alarm output will remain active until the alarm condition ceases to exist. The alarm will automatically reset when the conditions return to normal.

Mode 2: Constant & Manual Reset

In this mode, the alarm output will remain active until the alarm is reset manually. See parameters 42 and 52 for details.

Mode 3: Pulse & Auto Reset

In this mode, the alarm output will pulse on and off until the alarm condition ceases to exist. The pulsed modes are commonly used for audible alarms where a constant output would be considered distracting or awkward. The alarm will automatically reset when the conditions return to normal.

Mode 4: Pulse & Manual Reset

In this mode, the alarm output will pulse on and off until the alarm is reset manually. See parameters 42 and 52 for reset details. The pulsed modes are commonly used for audible alarms where a constant output would be considered distracting or awkward.

Parameter 42 & 52 – Alarm 1 & 2 Reset Configuration

This setting determines which actions will cause an active alarm to be silenced or reset.

Mode 1: No Silencing, Reset On Any Button Press

In this mode, an active alarm cannot be silenced. Once the alarm condition ceases to exist, however, any user-interface button may be pressed to cause a manual reset.

Mode 2: No Silencing, Reset On S2 Input High (Not Wired To Common)

Similar to Mode 1. Once the alarm condition ceases to exist, setting the S2 input to a high (+5V) state or allowing it to float disconnected will cause a manual reset.

Mode 3: No Silencing, Reset On S2 Input Low (Wired To Common)

Similar to Mode 1. Once the alarm condition ceases to exist, setting the S2 input to a low (COM) state or wiring it to common will cause a manual reset.

Mode 4: Silencing Enabled, Reset On Any Button Press

When the conditions for an active alarm persist, pressing any user-interface button will result in the alarm being silenced or deactivated, but not reset. A second attempt to reset the alarm must be made after the condition ceases to exist to clear the alarm.

Mode 5: Silencing Enabled, Reset On S2 Input High (Not Wired To Common)

Similar to Mode 4. Setting the S2 input to a high (+5V) state or allowing it to float disconnected will cause the alarm to be silenced or reset depending on the current state of the alarm conditions.

Mode 6: Silencing Enabled, Reset On S2 Input Low (Wired To Common)

Similar to Mode 4. Setting the S2 input to a low (COM) state or wiring it to common will cause the alarm to be silenced or reset depending on the current state of the alarm conditions.

Parameter 43 & 53 – Alarm 1 & 2 Display Flash On Alarm

This will cause the display to flash when an alarm condition is active. If the unit is in Dual Rate or Time modes, the display will only flash on the display that has the alarm. Example, if you have the alarm sounding on S2 and you are looking at S1 speed, the display will not flash until you look at S2. If the alarm is set for Always Active the display will not flash, but the output relay will be activated.

Parameter 44 & 54 – Alarm 1 & 2 Pulse on Time

This parameter defines the number of seconds the output should be enabled during the 'on' phase of an active pulsing alarm's output. See application samples for examples.

Parameter 45 & 55 – Alarm 1 & 2 Pulse off Time

This parameter defines the number of seconds the output should be disabled during the 'off' phase of an active pulsing alarm's output.

Parameter 46 & 56 – Alarm 1 & 2 Pulse Count

This setting determines how many pulses are outputted when the alarm is activated and is configured in pulse output style. *When 0 is entered, the unit will be set for continuous pulses while the alarm is active.*

Parameter 47 & 57 – Alarm 1 & 2 Lower Limit

This setting defines either the lower limit or lower end of a range for the alarm region. Alarm limits are set in display units without regard to decimal point or colon position. In Rate and Counter Modes, a limit of 123 could represent a display value of 123, 12.3, 1.23, or 0.123. When in Time Mode, a limit of 123 would represent 1:23 on the display.

Parameter 48 & 58 – Alarm 1 & 2 Upper Limit

This setting defines either the upper limit or upper end of a range for the alarm region. Alarm limits are set in display units without regard to decimal point or colon position. In Rate and Counter Modes, a limit of 123 could represent a display value of 123, 12.3, 1.23, or 0.123. When in Time Mode, a limit of 123 would represent 1:23 on the display.

Parameter 95 – Factory Default Command

When set to a value of 5, the unit will be reset to factory default settings. This can also be achieved by applying power to the unit with both the Enter and Down buttons depressed. *The programming jumper must be in the "On" position for this method to function.*

Parameter 98 – Save to User Default Area Command

When set to a value of 5, the unit will store all adjustable parameters to the user default area. The user default area is intended to be a location where an OEM or integrator can store settings specific to their application. Using this, an OEM can easily refresh their custom settings in the field if an end-user accidentally reconfigures the unit unsuccessfully. Another common use for this area is testing and initial setup. The user can store known-good settings here and easily experiment without the fear of losing the optimal configuration.

Parameter 99 – Restore from User Default Area Command

When set to a value of 1, the unit will restore the all adjustable parameters from the user default area. See parameter 98 for additional information.

FORWARD / REVERSE - TIMING CHARTS

FORWARD - RISING EDGE

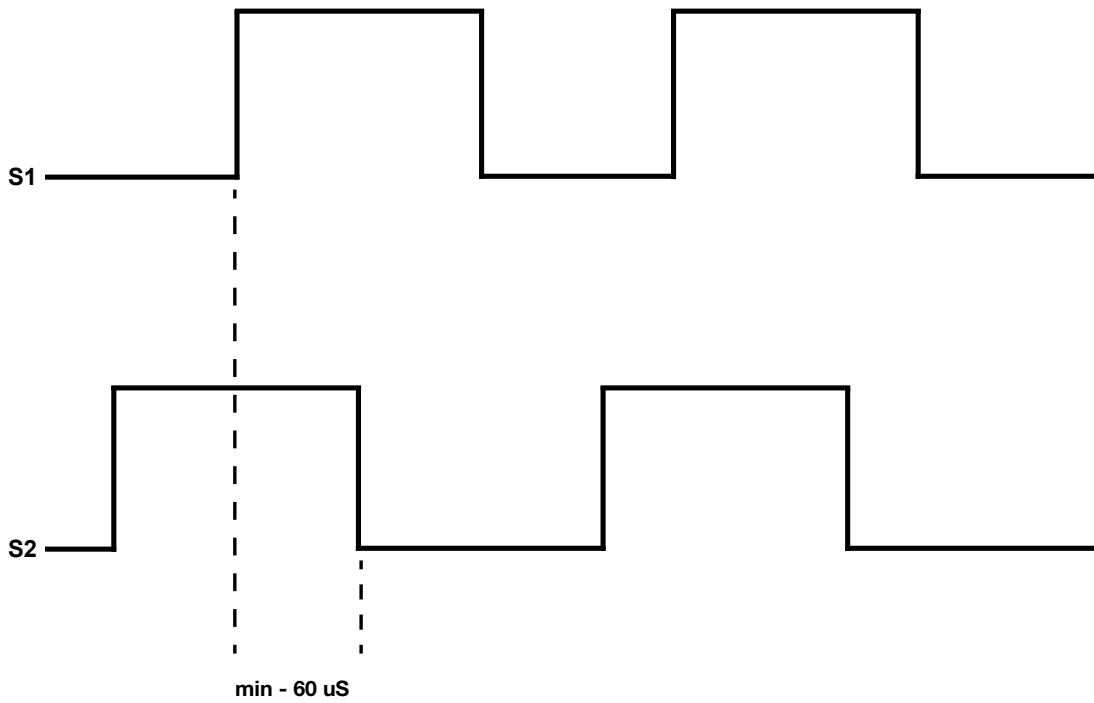

Forward - The Falling Edge of S2 must happen a minimum of 60 microseconds after the Rising Edge of S1.

REVERSE - RISING EDGE

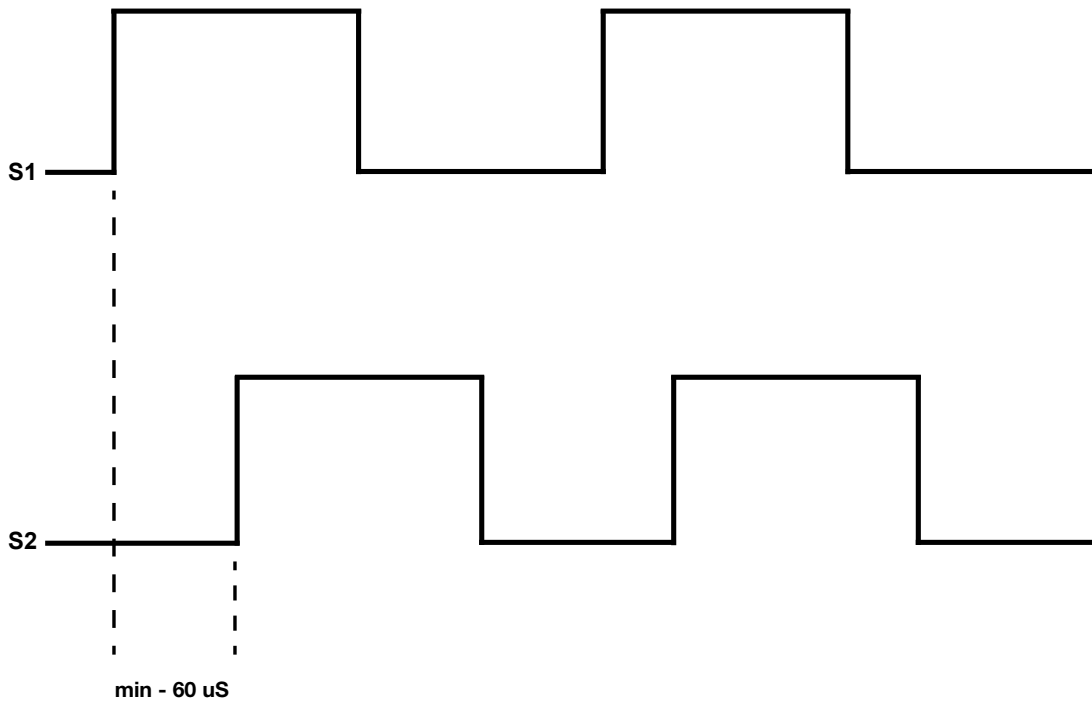

Reverse - The Rising Edge of S2 must happen a minimum of 60 microseconds after the Rising Edge of S1.

FORWARD - FALLING EDGE

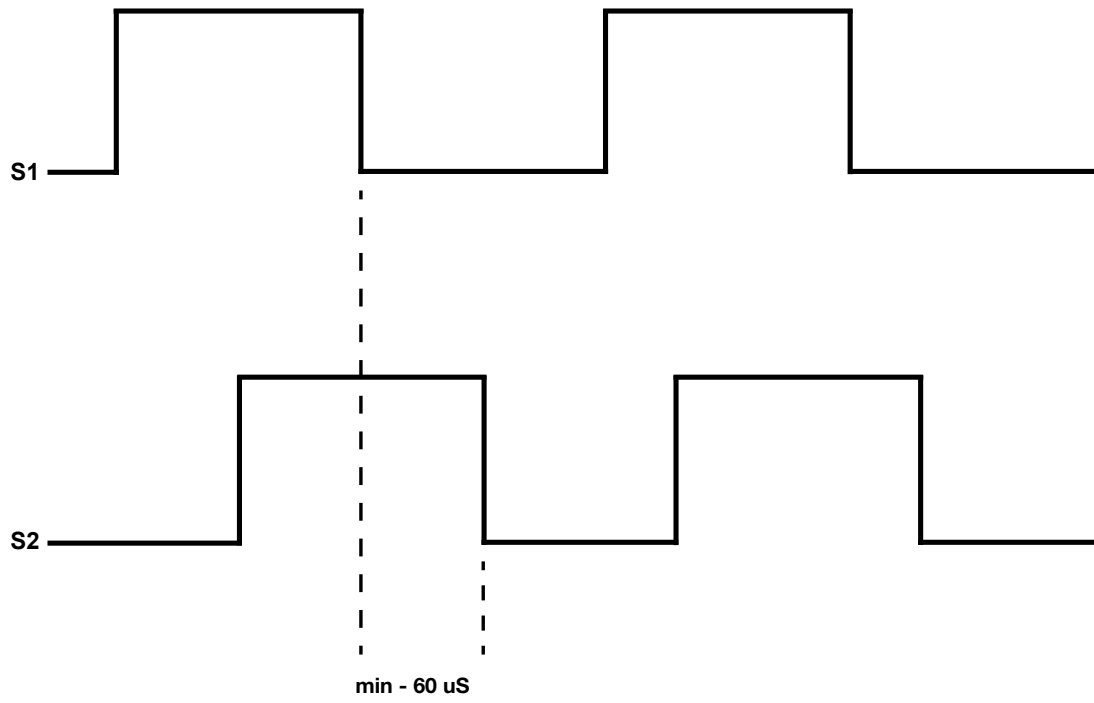

Forward - The Falling Edge of S2 must happen a minimum of 60 microseconds after the Falling Edge of S1.

REVERSE - FALLING EDGE

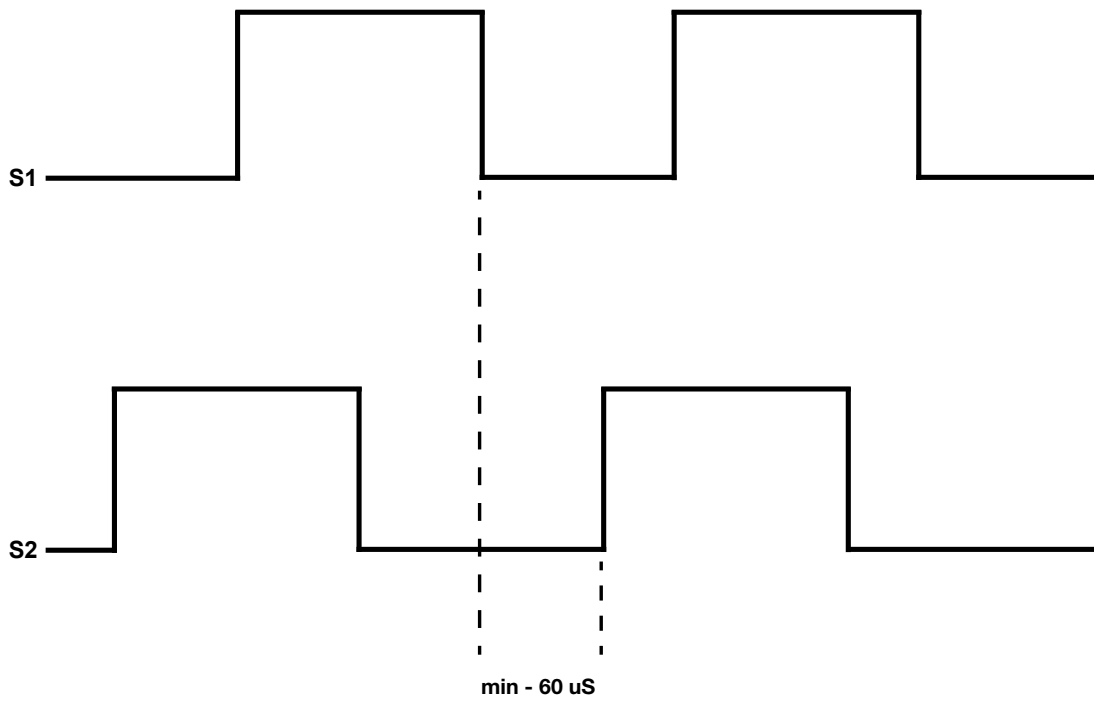

Application Examples

Pump Flow Monitor with Audible and Visual Alarm

Description:

A pump monitor which displays the pump rate in gallons per minute with an audible and visual alarm output which will warn the operator of excessively low flow conditions under 5.00 GPM. The alarm should not be able to be silenced and should be reset when any front-panel button is pressed. The display should indicate in the format "xx.xx" (GPM). Due to normal fluctuations in flow rates, it is desirable to have the display filter or average the value over 3 seconds to produce a more accurate and steady display.

Application Diagram:

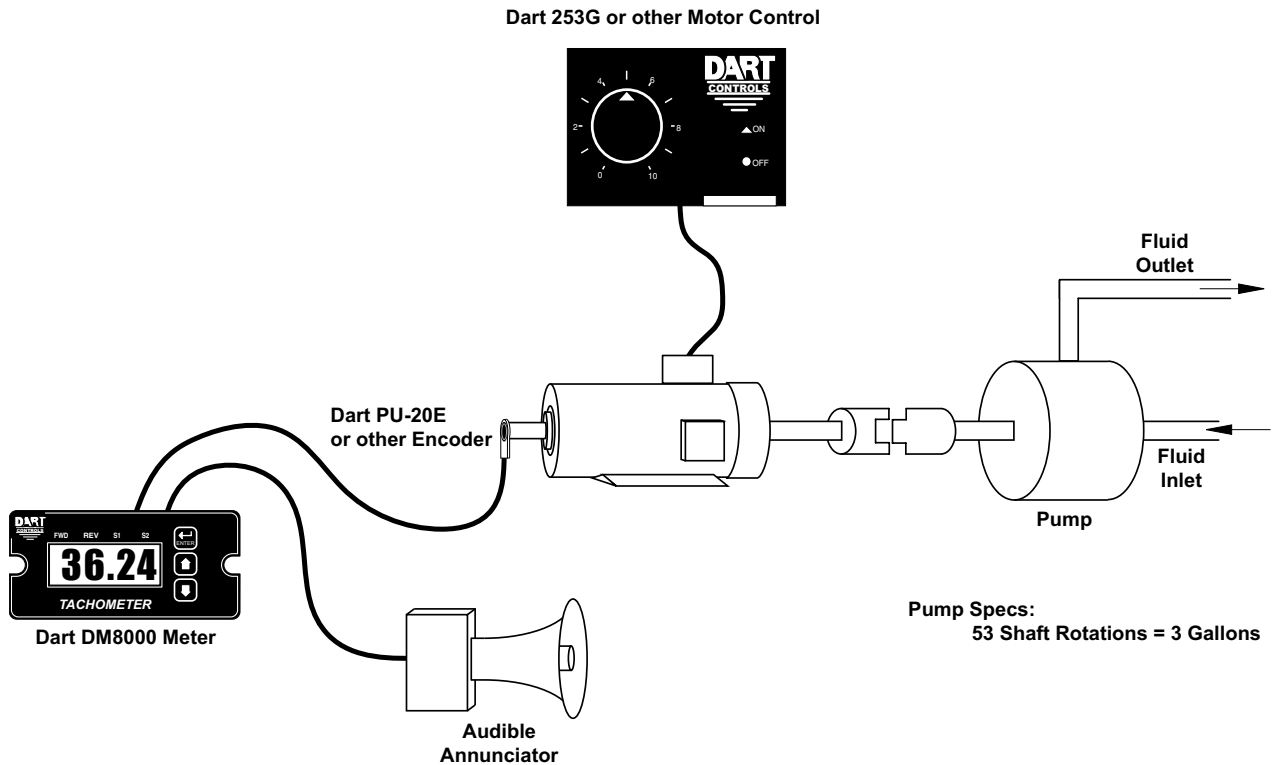

Wiring Diagram:

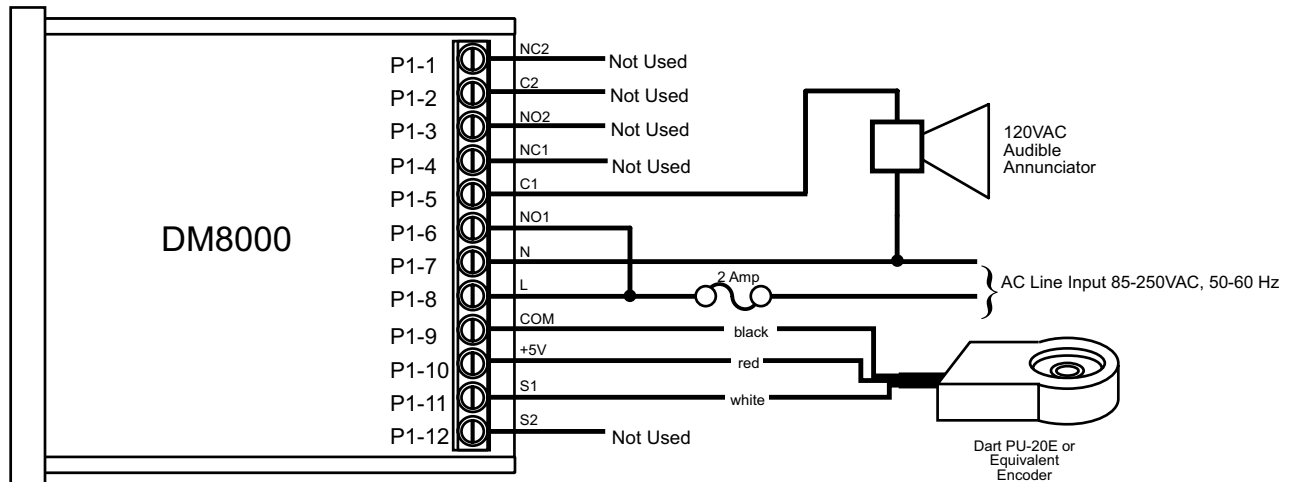

Parameter Configuration:

Parameter	Value	Notes
10	1	Rate Mode Setting (GPM is a rate-based unit)
20	300	Display should indicate 3.00 GPM (300) when motor at Reference RPM, parameter 21
21	53	This is the RPM at which the Display Reference, parameter 20, should be displayed
22	10	Pulses per revolution of shaft encoder or pickup is 10 PPR
24	3	Display filtering / averaging set to 3 seconds
25	2	Decimal point position set to XX.XX on display
40	3	Alarm active when display value is below lower limit
41	2	Constant alarm output with manual reset required
42	1	No silencing, reset on any button press
43	1	Flash display when alarm output is active
47	500	Lower limit setting for 5.00 GPM (500). Limits are entered without regard for decimal point position

Conveyor Oven Time Monitor with Over-Heating Alarm

Description:

An oven monitor displaying the “tunnel” time in minutes and seconds. The tunnel time is defined as the time it takes for the heated object on the conveyor to travel from point A to point B in the application diagram below. A visual indicator should activate if the tunnel time rises above a preset limit of 22 minutes and 30 seconds which could cause overheating of the processed material. The indicator should automatically reset when the tunnel time returns to the normal operating range. For ease of use, the display should be averaged over a period of 1 second.

Application Diagram:

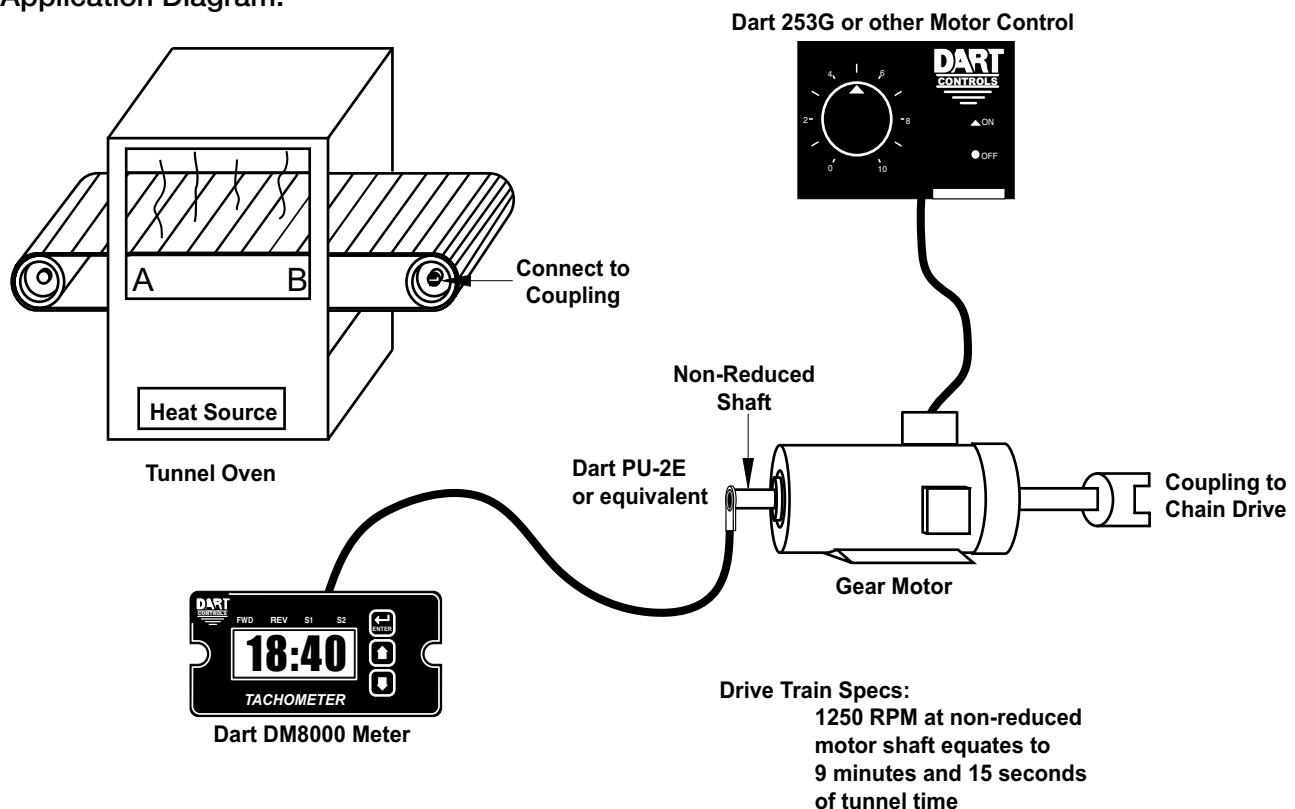

Wiring Diagram:

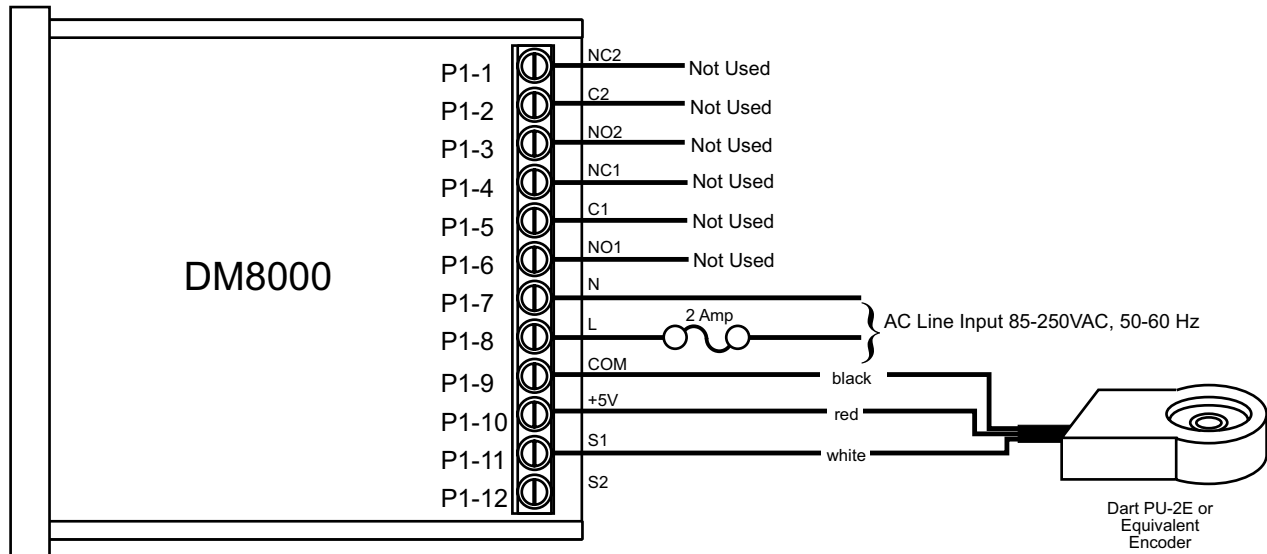

Parameter Configuration:

Parameter	Value	Notes
10	2	Time Mode Setting
20	555	Display should indicate 9:15 (555) when motor at Reference RPM, parameter 21. In time mode, all display values are entered in total number of seconds. For example, 555 = (9 minutes * 60 seconds-per-minute) + 15 seconds.
21	1250	This is the RPM at which the Display Reference, parameter 20, should be displayed.
22	1	Pulses per revolution of shaft encoder or pickup is 1 PPM
24	1	Display filtering / averaging set to 1 seconds
40	4	Alarm active when display value is above upper limit
41	1	Constant alarm output with automatic reset
43	1	Flash display when alarm output is active
48	1350	Upper limit setting for 22 minutes and 30 seconds. In time mode, all limits are entered in total number of seconds. For example, 1350 = (22 minutes * 60 seconds-per-minute) + 30 seconds.

Take-up / Pay-out Reel Material Measurement with Alarm

Description:

A take-up / pay-out system where the DM8000 displays a measurement of dispensed or accumulated material in linear yards. Once the desired amount of material, 1500 yards, has been dispensed or accumulated, an external light should illuminate to indicate that the specified material volume has passed. At this point, the user must be able to press a button on the user interface to reset the count to zero and the process repeats.

Application Diagram:

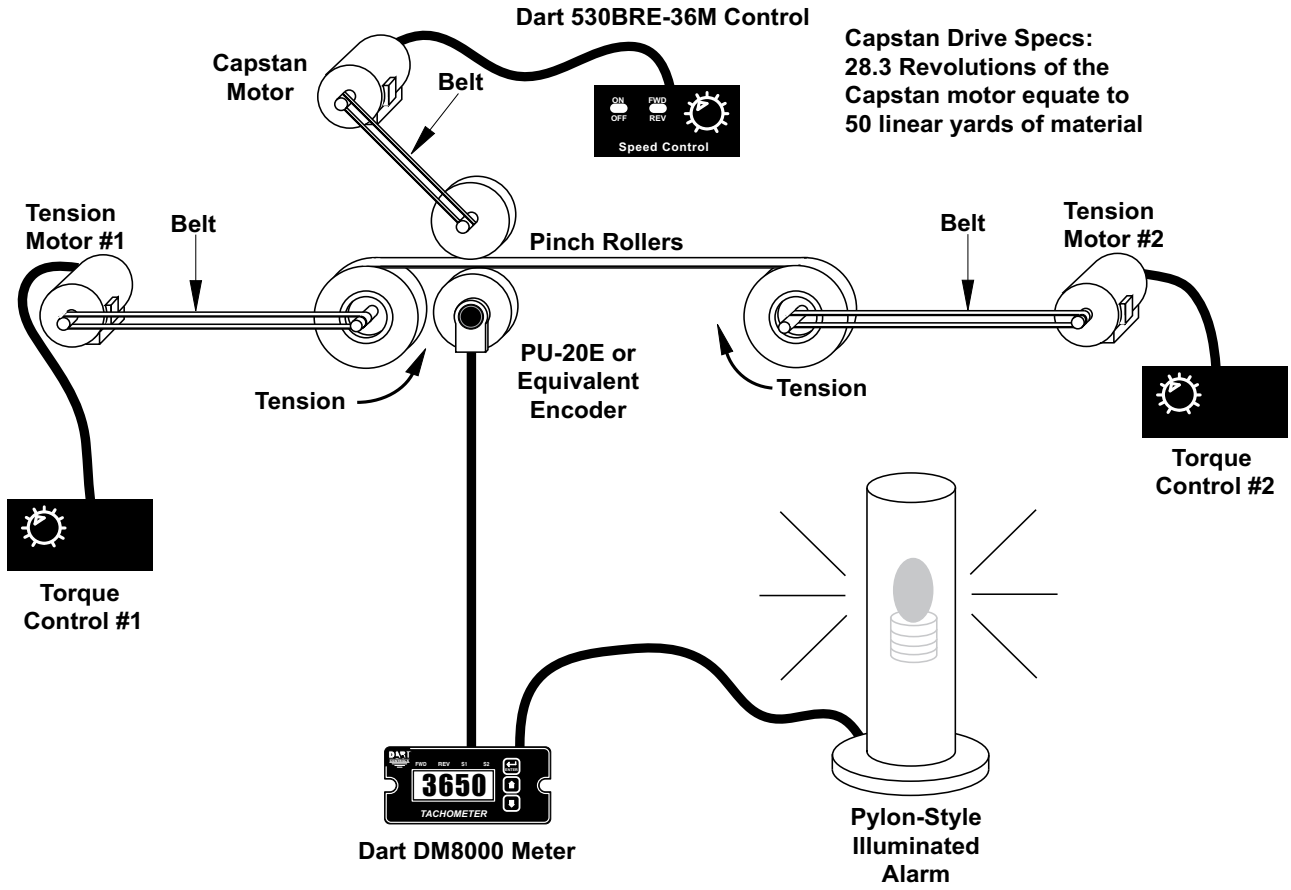

Wiring Diagram:

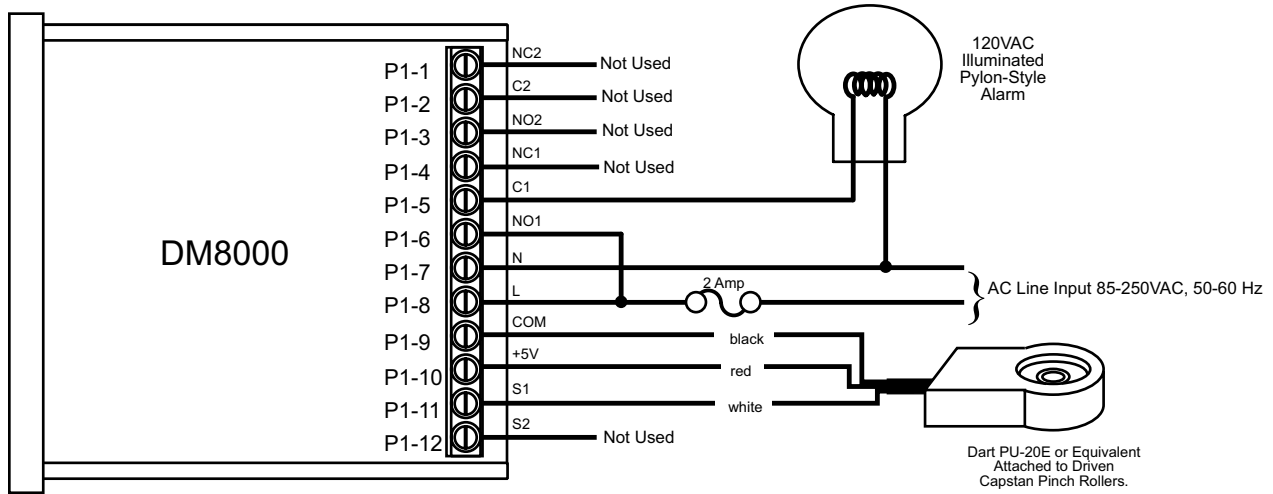

Parameter Configuration:

Parameter	Value	Notes
10	3	Up-Counter Mode Setting
16	2	Configure counter to reset on any button press
20	500	Display should increment 50 linear yards for each Reference Count, parameter 21. Because the initial values were 28.3 revolutions per 50 linear yards, each is multiplied by 10 to give an even number to increase accuracy since the display can be programmed in whole numbers.
21	283	In count mode, the Reference RPM is set in revolutions. 283 has been entered here to represent 28.3 revolutions and the Display Reference has also been multiplied by 10 to yield whole numbers.
22	10	Pulses per revolution of shaft encoder or pickup is 10 PPM
23	0	Note: Needs to be set to zero to get Count Mode to work
40	4	Alarm active when display value is above upper limit
41	2	Constant alarm output with manual reset required
42	1	No silencing, reset on any button press
48	1500	Upper limit setting for 1500 linear yards.

Bi-directional Incremental Position Display

Description:

A system is needed which will track the position of a bi-directional linear-motion platform and allow the user to select a home or zero position. The display should read in inches and indicate the position of the platform at all times.

Application Diagram:

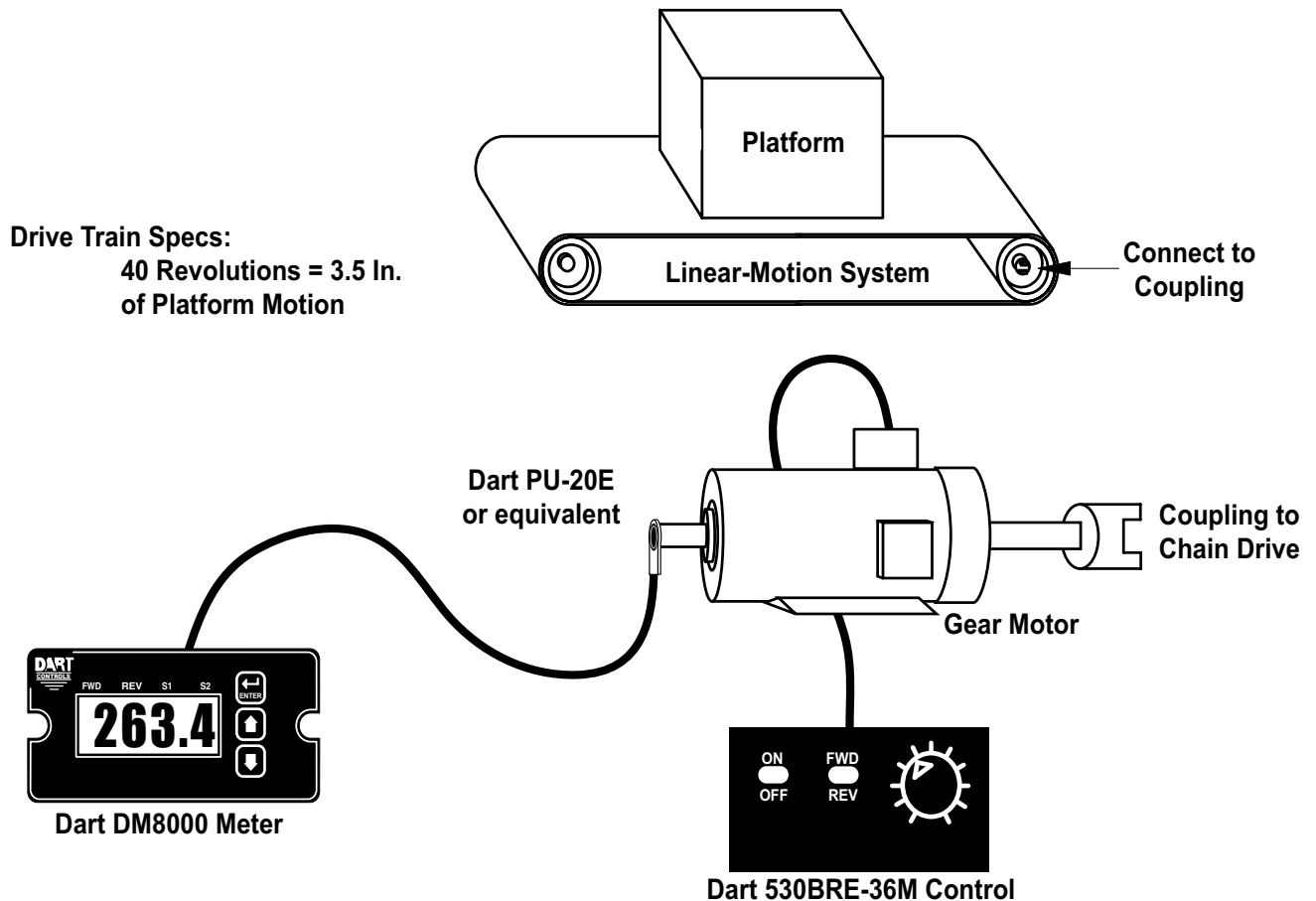

Wiring Diagram:

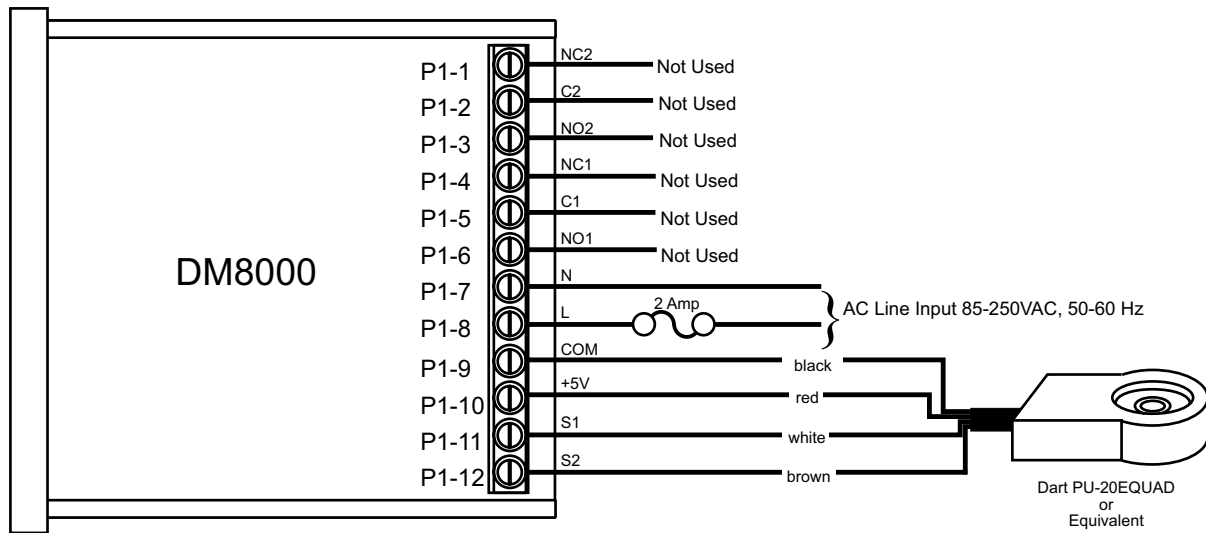

Parameter Configuration:

Parameter	Value	Notes
10	5	Up/Down Counter Mode
20	35	Because the initial values were 40 revolutions per 3.5 inches of platform motion, each is multiplied by 10 to give an even number to increase accuracy since the display can be programmed in whole numbers. Additionally, because of the decimal point position, the Display Reference is multiplied by 10 to generate the proper display format. Without the second multiplication by 10, the display would only read 3.5 inches when the drive motor turned 400 revolutions.
21	400	In count mode, the Reference RPM is set in revolutions. 400 has been entered here to represent 40 revolutions and the Display Reference has also been multiplied by 10 to yield whole numbers.
22	10	Pulses per revolution of shaft encoder or pickup is 10 PPM
23	0	Note: Needs to be set to zero to get Count Mode to work
25	3	Decimal point position set to XXX.X on display

Shared Display Between Two Pickups (Motors)

Description:

A new feature is the ability of the same display to share rate/time indication between two pickups - saving panel space and cost. There are several applications where this might be beneficial:

- Ratio Control (Batching / Blending)
- Synchronization of motors (Main / Feed converter)
- Water Treatment / Chemical Feed (% of main flow)

The DM8000 Parameter Configuration is discussed previously (pages 9-18).

Application Diagram:

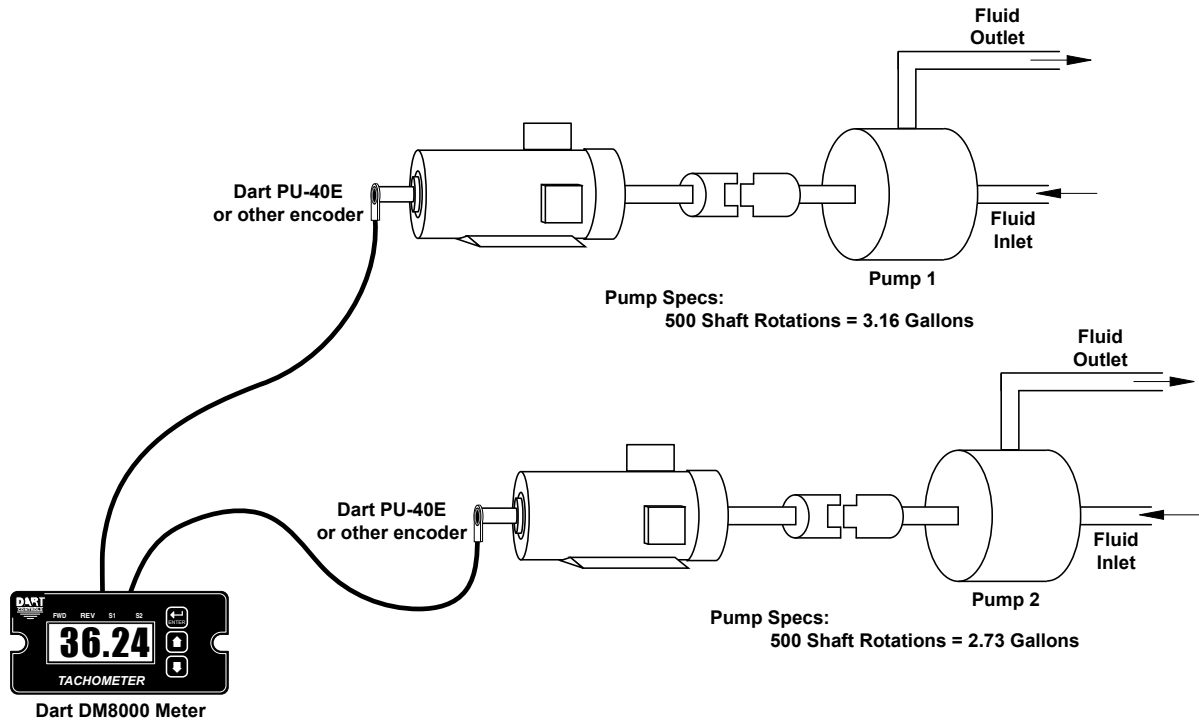

Wiring Diagram:

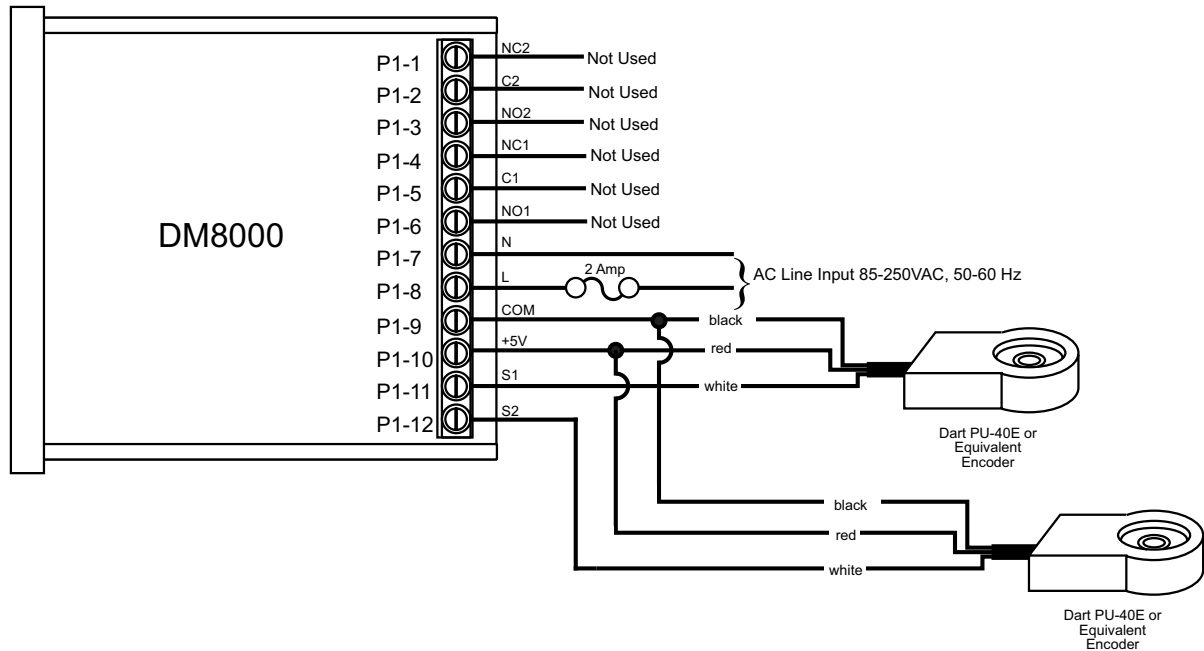

Parameter Configuration:

Parameter	Value	Notes
10	8	Dual Rate Mode Setting (GPM is a rate-based unit)
20	316	Display should indicate 3.16 GPM (316) when motor at Reference RPM, parameter 21
21	500	This is the RPM at which the Display Reference, parameter 20, should be displayed
22	10	Pulses per revolution of shaft encoder or pickup is 10 PPR
25	3	Decimal point position set to XXX.X on display
30	273	Display should indicate 2.73 GPM (273) when motor at Reference RPM, parameter 31
31	500	This is the RPM at which the Display Reference, parameter 30, should be displayed
32	20	Pulses per revolution of shaft encoder or pickup is 20 PPR
35	3	Decimal point position set to XXX.X on display

Troubleshooting

Problem	Possible Case	Solution
Display is blank	Power not applied	Using a volt meter, verify that a voltage between 85 and 250VAC is measured between the L and N terminal block positions.
	Defective unit	Contact technical support for additional help and instructions.
Display is dim	Display intensity parameter is too low	Editing and increasing the display intensity parameter should cause the display digits to become brighter.
When power is applied, "LF-L" is displayed	AC line supplying power to unit has too much noise	Review routing of power wires in machine to minimize electrical noise. Look for other devices which share the same circuit which may be producing unacceptable levels of line noise. In some applications, such as welding equipment, a careful regimen of applying an AC line filter, re-routine wires, dividing circuits, using shielded cable, and properly grounding devices will usually solve the problem.
	AC line supplying power to unit has an abnormally low frequency	The unit is designed to operate with AC lines from 48-62 Hertz (cycles per second). This is typically not a problem because the international standards are 50 and 60 Hertz.
When power is applied, "LF-H" is displayed	AC line supplying power to unit has too much noise	Review routing of power wires in machine to minimize electrical noise. Look for other devices which share the same circuit which may be producing unacceptable levels of line noise. In some applications, such as welding equipment, a careful regimen of applying an AC line filter, re-routine wires, dividing circuits, using shielded cable, and properly grounding devices will usually solve the problem.
	AC line supplying power to unit has an abnormally high frequency	The unit is designed to operate with AC lines from 48-62 Hertz (cycles per second). This is typically not a problem because the international standards are 50 and 60 Hertz.
The first or second alarm output does not seem to function	Second alarm output not installed in unit	Only units with the -R option have a second relay output. See the model and options tables for available configurations.
	Second alarm output parameters not configured properly	Second alarm output parameters not configured properly Review alarm output #2 parameters. The first and second alarm relay outputs can be tested by selecting the "Always On" value for the Activation Condition parameters for the respective alarm output. When doing this, the relay click should be audible and the NC (Normally Closed) and C (Common) terminals should become internally shorted at the terminal block.

Technical Support Options

- Visit the Dart Controls Web Site at: www.dartcontrols.com
- Email technical support at: sales@dartcontrols.com
- Telephone technical support at 317-873-5211

What's Special About www.dartcontrols.com?

- Changes to printed material and product offerings first appear online
- Product manuals and other literature are easily accessible
- All information can be easily displayed or printed as needed

- Notes -

REPAIR PROCEDURE

In the event that a Product manufactured by Dart Controls Incorporated (DCI) is in need of repair service, it should be shipped, freight paid, to: Dart Controls, Inc., 5000 W. 106th Street, Zionsville, IN. 46077, ATTN: Repair Department. Please include Name, Shipping Address (no P.O. Box), Phone Number and if possible, e-mail address.

Those orders received from anyone without an existing account with DCI must specify if they will be paying COD or Credit Card (Master Card/Visa/American Express). This information is required before work will begin. If you have an account with Dart your order will be processed according to the terms listed on your account. Products with Serial Number date codes over 5 years old will automatically be deemed Beyond Economical Repair (BER). A new, equivalent device will be offered at a substantial discount.

Completed repairs are returned with a Repair Report that states the problem with the control and the possible cause. Repair orders are returned via UPS Ground unless other arrangements are made. If you have further questions regarding repair procedures, contact Dart Controls, Inc. at 317-873-5211.

YOUR MOTOR SPEED CONTROL SOLUTION PROVIDER

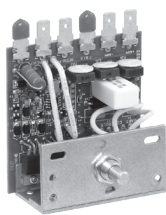

OEM Chassis SCR Drives
Dual Input voltage, adjustable HP range, isolated signal follower and reversing options

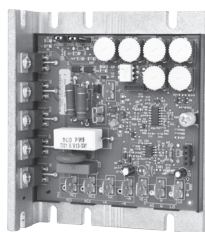

NEMA 4/4X SCR Drives
Dual Input voltage, adjustable HP range, isolated signal follower and reversing options

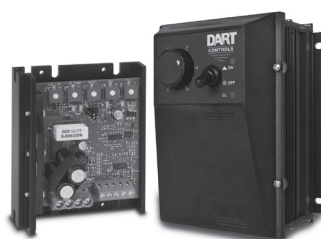

Low Voltage/Battery PWM Drives
Chassis and NEMA 4X versions, speed pot and signal follower operation



Digital SCR Drives
Closed loop accuracy, 4-20mA and serial communications, integral programmable display



Brushless DC Drives
Closed loop accuracy, line and low voltage versions through 1 HP



Digital Accessory & Resale Items

Motors to 700 HP, VFD's to 200 HP, NEMA rated encoder, digital programmable potentiometers and tachometers

Dart Controls, Inc. is a designer, manufacturer, and marketer of analog and digital electronic variable speed drives, controls, and accessories for AC, DC, and DC brushless motor applications.

Shown above is just a sampling of the expanded line of Dart controls that feature the latest in electronic technology and engineering. Products are manufactured in the U.S.A. at our Zionsville (Indianapolis, Indiana)

production and headquarters facility - with over 2,000,000 variable speed units in the field.

In addition to the standard off-the-shelf products, you can select from a wide variety of options to customize controls for your specific application. For further information and application assistance, contact your local Dart sales representative, stocking distributor, or Dart Controls, Inc.

Dart Controls, Inc.

Manufacturer of high quality DC and AC motor speed controls and accessories since 1963.

5000 W. 106th Street
Zionsville, Indiana 46077
Phone: (317) 873-5211
Fax: (317) 873-1105

www.dartcontrols.com
ISO9001 REGISTERED
MADE IN USA