

ASP10 CONTROL SERIES

DART

CONTROLS

Instruction Manual

PROGRAMMABLE DIGITAL "CLOSED LOOP" MOTOR SPEED CONTROL SYSTEM FOR AC AND DC DRIVES



5000 W. 106th Street
Zionsville, Indiana 46077

Phone (317) 873-5211
Fax (317) 873-1105
www.dartcontrols.com

Quick Jump

What models and options are available?

See page 3.

Looking for detailed specifications?

See page 3.

Want to get started fast?

See basic electrical hook-up details on page 6.

See mechanical installation details on page 4.

See some sample applications starting on page 21.

Need Help?

See troubleshooting on page 25.

Warranty

Dart Controls, Inc. (DCI) warrants its products to be free from defects in material and workmanship. The exclusive remedy for this warranty is DCI factory replacement of any part or parts of such product which shall within 12 months after delivery to the purchaser be returned to DCI factory with all transportation charges prepaid and which DCI determines to its satisfaction to be defective. This warranty shall not extend to defects in assembly by other than DCI or to any article which has been repaired or altered by other than DCI or to any article which DCI determines has been subjected to improper use. DCI assumes no responsibility for the design characteristics of any unit or its operation in any circuit or assembly. This warranty is in lieu of all other warranties, express or implied; all other liabilities or obligations on the part of DCI, including consequential damages, are hereby expressly excluded.

NOTE: Carefully check the control for shipping damage. Report any damage to the carrier immediately. Do not attempt to operate the drive if visible damage is evident to either the circuit or to the electronic components.

All information contained in this manual is intended to be correct, however information and data in this manual are subject to change without notice. DCI makes no warranty of any kind with regard to this information or data. Further, DCI is not responsible for any omissions or errors or consequential damage caused by the user of the product. DCI reserves the right to make manufacturing changes which may not be included in this manual.

WARNING

Improper installation or operation of this control may cause injury to personnel or control failure. The control must be installed in accordance with local, state, and national safety codes. Make certain that the power supply is disconnected before attempting to service or remove any components!!! If the power disconnect point is out of sight, lock it in disconnected position and tag to prevent unexpected application of power. Only a qualified electrician or service personnel should perform any electrical troubleshooting or maintenance. At no time should circuit continuity be checked by shorting terminals with a screwdriver or other metal device.

Table of Contents

Introduction	2
General Features	2
Models & Options	3
Model Options	3
Available Options	3
Recommended Accessories.....	3
Specifications	3
Electrical	3
Mechanical	3
Environmental.....	4
Mechanical Installation	4
Exploded Panel View	4
Cut-out and Mounting Dimensions	4
PU-E Series Pickup Installation.....	5
Electrical Installation & Diagrams	6
P1 Terminal Block Hook-Up Diagram	6
P1 Terminal Block Descriptions	7
-1 Option Wiring.....	7
Basic Operating Instructions	8
Control Algorithm Discussion	8
Pulse-Accumulation Loop PI Tuning	8
Master (Rate and Time) and Follower (Ratio) Modes Explained	9
Visual Reference	9
How to Change a Parameter's Value (The Short Story)	10
Operating the User Interface (The Long Story)	10
Detailed Configuration Instructions	11
Default Configuration	11
Resetting the Unit to Factory Defaults	11
JP1 (Program Enable Jumper)	11
Software Parameters	12
Parameter Descriptions	14
Application Examples	21
Pump Controller with Audible and Visual Alarm	21
Conveyor Oven Controller with Two Preset Process Times.....	22
Synchronized Conveyor Controller with Jog Switch	23
Troubleshooting	25
Technical Support Options.....	25
What's Special About www.dartcontrols.com ?	25

Introduction

The ASP10 process controller is a compact, microprocessor-based unit capable of being either field or factory configured for a number of industry's motion control needs. These controls are designed around a pulse-accumulation PI algorithm. They can be easily configured to operate as a digital speed controller, time-based process controller, or a ratiometric follower controller in master-slave systems. Utilizing Dart's new modular bus design techniques, the ASP series is ideal for volume OEM applications requiring specialized inputs and outputs. Contact Dart Controls' Sales Department for details. This flexibility makes the ASP series ideal for applications such as:

Water and Waste Treatment Systems

Conveyor Oven Controllers

Synchronized Conveyor Lines

Its durable 1/8 DIN aluminum housings can be easily mounted in a panel or control cabinet. New optional pluggable terminal block allows the installer to quickly install or replace units without the hassle of physically removing and reattaching wires. The units can be ordered with either standard European-style terminal block or optional "pluggable" connector.

General Features

- Microprocessor-based design combines the ultimate in responsiveness and accuracy in one package
- Digital closed-loop algorithm ensures long-term accuracy of +/-1/2 RPM of set speed or equiv.
- Non-volatile memory stores adjustable parameters even when power has been removed
- Factory or field programmable via front-panel keypad
- Adjustable parameters include min, max, accel, decel, display options, alarm options, etc.
- Internal program-enable jumper selectively prevents tampering with unit's configuration
- Universal power supply accepts line voltages inputs from 85-265VAC @ 50-60Hz without switches or jumpers. The unit automatically adjusts as needed.
- Transient voltage protection prolongs unit's life in harsh industrial environments
- Compatible with a variety of signal input types including: Hall-Effect Pickups, Photoelectric, TTL, etc.

Note: Open collector devices must be capable of sinking 3mA.

- Self-contained power supply for external sensor, limited to 5V @ 50mA
- Programmable alarm output with Form C contacts rated to 250VAC @ 5A
- 1/8 DIN durable aluminum housing for panel mounting.
- Large 4 digit, 1/2" LED display
- G.E. Lexan membrane and gasket (which are included) meet NEMA 4X standards when used with NEMA 4X enclosures
- European terminal block or pluggable terminal block available
- Wide operating ambient temperature range of -10C to 45C (14F to 113F)
- Multiple operating modes including:
 - Master, Rate Mode – Controls in rate unit such as RPM, Gallons per Second, etc.
 - Master, Time Mode – Controls in time unit such as HH:MM, MM:SS, SS:TT, or other unit
 - Follower Mode – Controls in percentage of master rate. This mode allows the ASP10 controller to precisely follow the actions of a master process without any long-term loss of position.

Models & Options

Model Options

Model	Input Voltage @ 50 - 60Hz	Output Voltage	Pickup or Encoder Required?
ASP10	85-265VAC	0-2 VDC THROUGH 0-24 VDC	Yes

Available Options

Option Suffix	Description	Example
-1	Expansion board which adds support for remote push button wiring via a European-style terminal block.	ASP10-1
-P	Optional pluggable European-style terminal block	ASP10-P
-9	Blank Lexan	ASP10-9

Recommended Accessories

Model	Description	Pulses per Revolution	RPM Range When Used With MD10P & MD3P
PU-2E	Hall-Effect Pickup, Single Channel	1	1.0 – 50,000 RPM
PU-4E	Hall-Effect Pickup, Single Channel	2	0.5 – 25,000 RPM
PU-20E	Hall-Effect Pickup, Single Channel	10	0.1 – 5,000 RPM
PU-40E	Hall-Effect Pickup, Single Channel	20	0.05 – 2,500 RPM

Specifications

Electrical

Line Input Voltage.....	Any Voltage from 85-265 VAC
Line Input Frequency.....	Any Freq. from 48-62 Hertz
Pulse Signal Input Voltage Range.....	0-5VDC to 0-24VDC square wave
Pulse Signal Input Frequency Range.....	0 – 50,000 Pulses per Minute (Higher frequencies are possible when using internal frequency divisor / prescaler)
Display Range.....	0.001 – 9999
Units of Operation.....	User Programmable, any Unit
Onboard Sensor / Pickup Power Supply.....	5V @ 50mA
Isolated Alarm Relay Output Ratings.....	250VAC @ 5A
Pot Lo/Hi supply VDC range.....	0-2 VDC through 0-24 VDC
Pot wiper VDC range.....	Pot Lo +50mV through Pot Hi -50mV

Mechanical

Display Type	LED, Red, 4 Digit, ½" Height
Housing Type (with supplied gasket in NEMA 4X panel).....	1/8 DIN NEMA 4X
Connector Style (pluggable connector optional).....	12-position 5mm European Style
Terminal Block Torque Setting.....	4.4 in. lb. Max or .5Nm
Faceplate Material.....	Polycarbonate with GE Lexan Overlay
Housing Material.....	Aluminum
Length (Required Panel Depth).....	4.625", 117.48mm
Faceplate Width	4.539", 115.29mm
Weight ASP10.....	0.900 lb, 14.4 oz, 408.22g

Environmental

Operating Temperature Range.....	-10C to 45C (14F to 113F)
Operating Humidity Range.....	95%, non-condensing

Mechanical Installation

Exploded Panel View

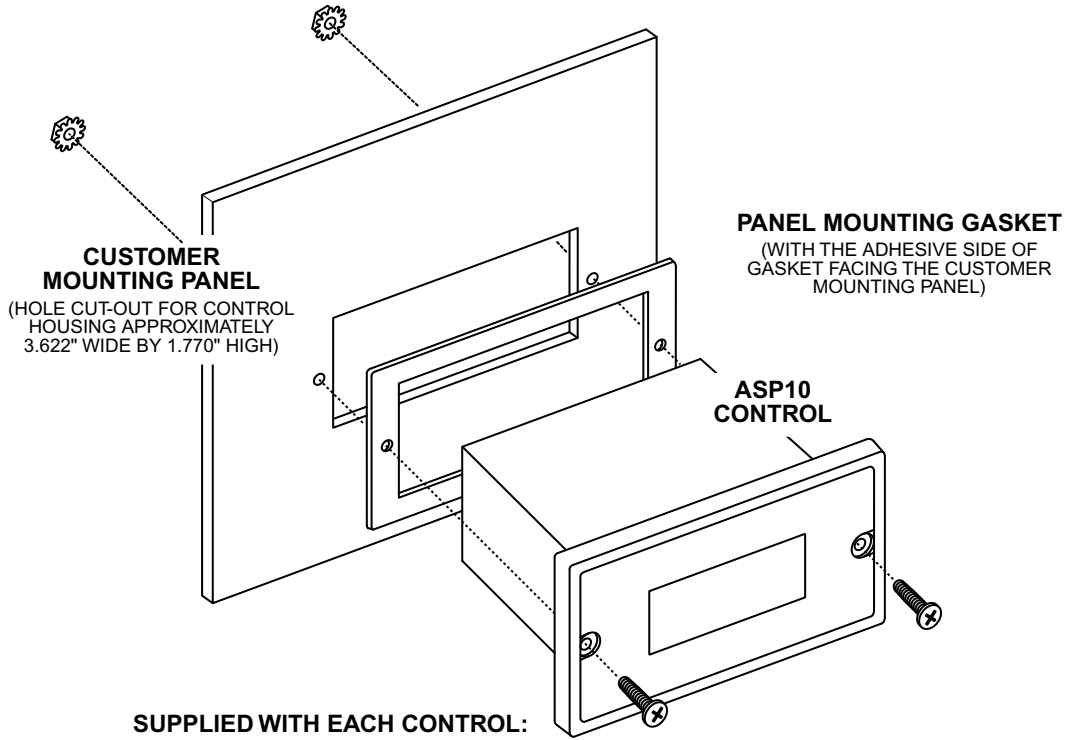

- 1) GASKET
- 2) (2) 6-32 X 3/4 PANHEAD BLACK OXIDE STAINLESS SCREWS
- 3) (2) #6 NUT WITH LOCKWASHER

Cut-out and Mounting Dimensions

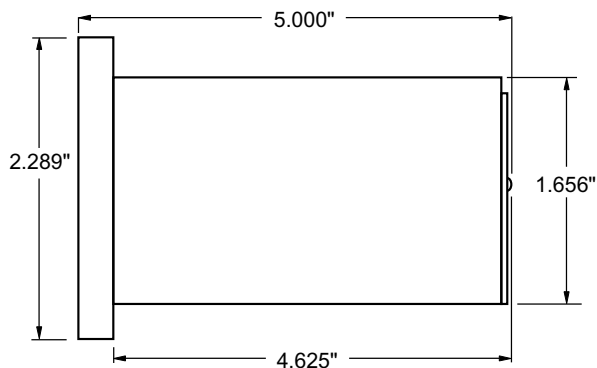
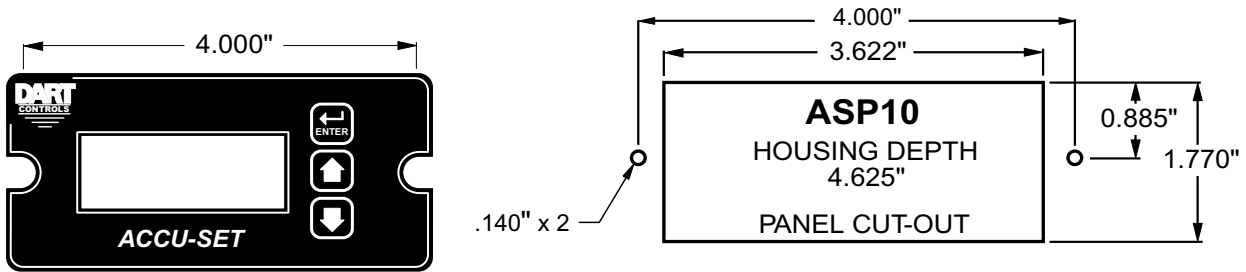

PU-E Series Pickup Installation

The PU-E series pickup is an economical way to monitor motor speed. Its patented design provides for ease of installation in otherwise difficult to reach areas. The PU-E operates from a +5V power supply, producing a 5 volt square wave whose frequency is proportional to speed. This signal is fed into the ASP10 controller as a speed or position reference for the microprocessor.

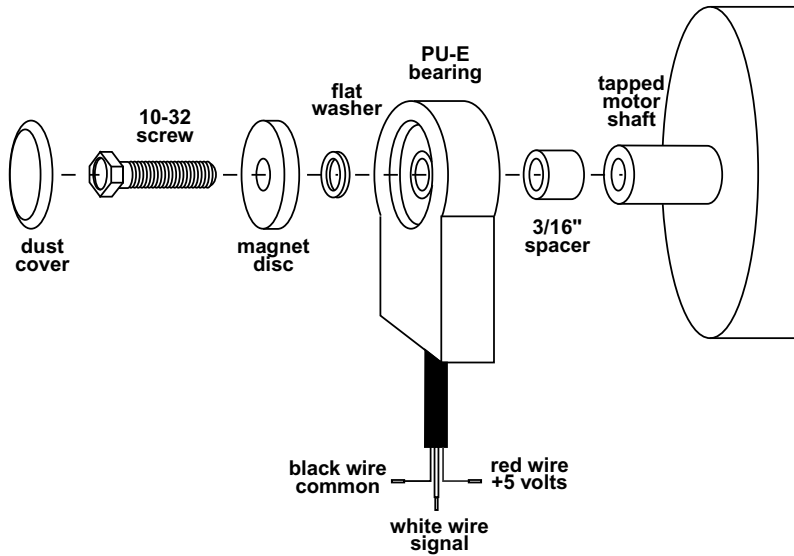

Model Number	Pulses per Revolution
PU-2E	1
PU-4E	2
PU-20E	10
PU-40E	20

Dimensions

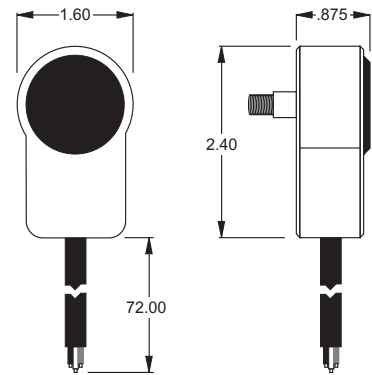

No other mounting screws are necessary, as the cord will keep the unit from rotating.

Caution: The PU-E cord should not be grouped with other wires or cords. For applications with PU-E wire over 6 feet long, or noisy environments, a shielded cable is recommended. Connect the shield to the common terminal on the ASP10 controller, leaving the shield on the PU-E end floating.

Electrical Installation & Diagrams

P1 Terminal Block Hook-Up Diagram

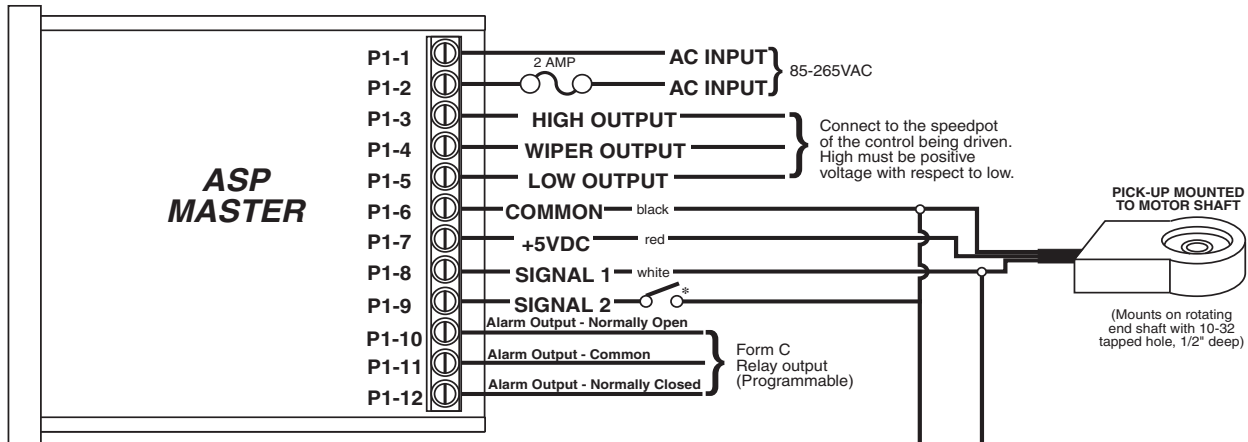

* P1-9 signal input may be programmed for a number of functions. Incl (jog, inhibit, etc.)

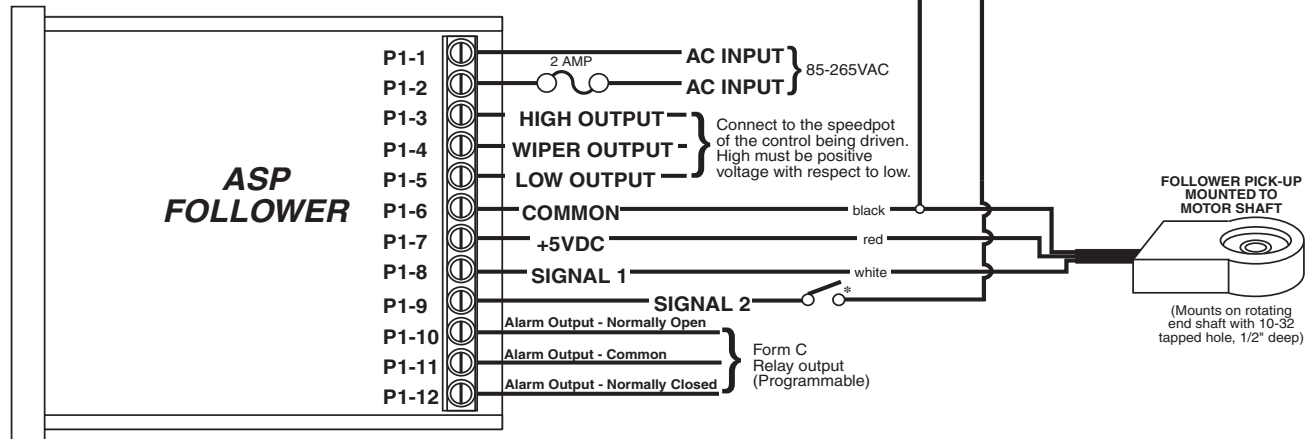

* Optional Inhibit Switch

P1 Terminal Block Descriptions

- P1-1 (AC / N) – For single phase AC lines connect the Neutral side of your AC line to this terminal. For systems with two hot AC lines, connect either of the Hot AC lines to this terminal.
- P1-2 (AC / L) – For single phase AC lines connect the Hot side of your AC line to this terminal. For systems with two hot AC lines, connect either of the Hot AC lines to this terminal.
- P1-3 (HI) - This is the POT HI reference terminal. This terminal must be connected to the most positive speed pot input terminal of the partner control. This terminal will generally be referred to as Pot HI or +V for positive supplies and Com for negative supplies.
- P1-4 (WP) - This is the Wiper output terminal. This terminal will output an analog voltage signal proportional to the referenced voltage signals connected to P1-3 (HI) and P1-5 (LO). This terminal should be connected to the wiper or signal input of the partner control.
- P1-5 (LO) - This is the POT LO reference terminal. This terminal must be connected to the most negative speed pot input terminal of the partner control. This terminal will generally be referred to as Pot LO or Com for positive supplies and –V for negative supplies.
- P1-6 (COM) – This is the common point for the control logic. The speed sensor common lead as well as any other source needing to reference the control common will be connected to this terminal.
- P1-7 (+5V) – This is a self-contained +5VDC power supply capable of up to 50mA. The speed sensor supply lead can be connected to this terminal for its power source.
- P1-8 (S1) – This is the signal input terminal for the motor’s digital pickup or encoder.
- P1-9 (S2) – This input can be programmed to perform a number of advanced functions. In Follower Mode, this input is the signal input terminal for the master’s digital pickup or encoder. In Master modes (Rate and Time), this input can be configured to function as an emergency stop, inhibit, or jog command.
- P1-10 (1NO) – This is the normally-open contact of the user assignable relay output.
- P1-11 (1C) – This is the common contact of the user assignable relay.
- P1-12 (1NC) – This is the normally-closed contact of the user assignable relay output.

-1 Option Wiring

The -1 option board is a module which allows external up and down push buttons to be wired to the unit. These buttons operate exactly like the Up and Down buttons on the user interface. This module is commonly used to allow PLCs or hand-held pendants to operate the front-panel remotely. Wires for the external buttons are attached via a 3mm European terminal block on the -1 option board. The buttons are activated by shorting the terminal labeled Com to either the Up or Down terminal.

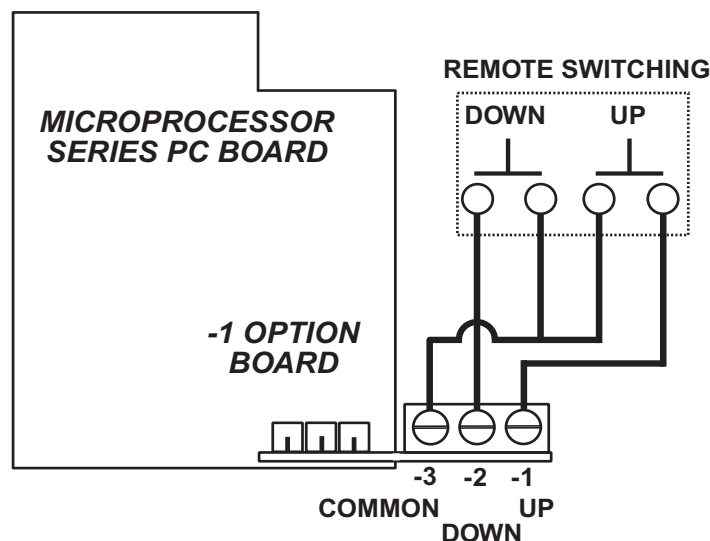

Basic Operating Instructions

Control Algorithm Discussion

The ASP10 controller is based on a pulse-accumulation algorithm. The advantage to this type of algorithm is that it allows the control to follow a master process with exceptional long-term accuracy. The ASP10 controller has three parameters which allow the user to adjust how aggressively the unit drives the partner motor control to achieve the motor target speed. These 3 parameters are as follows:

P Gain - This is the proportional gain for the control loop. In pure pulse-accumulation algorithms, there is no loop error to base a 'P' factor on; therefore, these units must estimate error based on several control loop factors. Those who are familiar with PID control tuning should be aware that the ASP10 control's P Gain is somewhat different than that of standard velocity-form PID algorithms. The P Gain is a function of instantaneous error, a measure of the difference between the target (desired) speed and the current speed of the motor.

I Gain - This is the integral gain for the control loop. The I Gain is a function of accumulated error, a measure of the difference between the target (desired) speed and the current speed of the motor.

Pulse Accumulation Limit - This parameter allows the user to limit the maximum number of pulses the drive will accumulate prior to intentionally losing count and therefore long-term accuracy. See the details for parameter 29 in the Parameter Description section.

Pulse-Accumulation Loop PI Tuning

Many applications do not require tuning of the P and I Gain parameters beyond the supplied factory default settings. If more responsiveness is desired or if the motor oscillates an unacceptable amount when changing speeds, it may be necessary to adjust the P and I gains to obtain optimal performance.

Increasing the P and/or I gains will cause the control to drive the motor more aggressively. Decreasing the P and/or I gains will cause the control to perform more sluggishly. Properly tuning the P and I gains encompasses more than independently adjusting the P and I. The ratio between the two is very important as well. Although initial tuning can be a time-consuming task, here is a basic outline of how to proceed:

Test Procedure: Adjust the target (displayed) speed as expected during normal operation, including testing inhibit and jog transitions if applicable.

Tuning Method:

- Step 1 - Connect the ASP10 and the partner motor control it is driving to a loaded motor with application's anticipated load for realistic tuning.
- Step 2 - Make the following adjustment to the controller being driven by the ASP10. Set compensations settings such as IR or slip to minimum setting. Set any accel, decel adjustments to their minimum setting. Min. setting should not be set to a value high enough to cause motor rotation. A Max. adjustment must be set to a setting that is equal to or greater than the highest speed required for your application.
- Step 3 - Perform test procedure.
- Step 4 - If control performs adequately, stop tuning and record settings.
- Step 5 - If control is too sluggish or takes too long to reach the target speed, then try increasing I Gain slightly (add 250). Perform the test procedure again. Continue increasing I Gain until motor starts to slightly oscillate or become unstable. At this point, decrease the I Gain by 250.
- Step 6 - If control is too aggressive or is causing the motor to oscillate or become unstable, then try decreasing I Gain slightly (subtract 250). Perform the test procedure again. Continue decreasing I Gain until motor starts to stabilize and regulate more accurately.
- Step 7 - Once I is set, adjust P Gain and perform test procedure. In this control, additional P Gain may or may not improve response or stability. Experimentation will be required.

Accel and decel settings have a small impact on PI tuning as well. Specifically, when accel and decel settings are extremely fast, they can cause the control loop to perform more sluggishly. Another thing to keep in mind is that PI tuning also affects accel and decel times. For instance, a sluggishly tuned PI control loop may take longer than the programmed accel and decel times to reach the target; whereas, an aggressively tuned PI control loop will reach the target faster.

Master (Rate and Time) and Follower (Ratio) Modes Explained

The ASP10 controller has two basic modes of operation, master and follower. In the Master modes, the controls are capable of operating independently; whereas, in the Follower Mode, the control requires a signal from a master to operate. The Follower Mode is used in applications which require the ASP10 to closely follow a master process. For example, if a factory has ten conveyors which must be synchronized over long periods of time, an industrial engineer could use one ASP10 as a master control for the first conveyor and nine ASP10s as slaves or followers which would receive their speed commands from the first conveyor's master control or pickup.

In Master Rate Mode, the ASP10 controls the rate of the motor by tracking the motor's pickup pulses which are applied to signal input 1 (S1). In this mode, the display indicates in rate units such as Gallons-per-minute, feet-per-second, and RPM.

In Master Time Mode, the ASP10 controls the process time by tracking the motor's pickup pulses which are applied to signal input 1 (S1). In this mode, the display indicates in time units such as HH:MM or MM:SS, where HH is hours, MM is minutes, and SS is seconds. This mode is most-commonly used in time-sensitive processes such as conveyor ovens and plating applications.

In Follower Mode, the ASP10 tracks the number of pulses which are applied to the master signal input (S2). From these pulses, it calculates the rate of the master process. This rate is then multiplied by the percentage which is displayed on the user interface. The display is in 0.1% of master units. For example, 675 = 67.5 percent of master speed. A master running at 1350 RPM, would cause the follower to run its motor at $67.5\% * 1350 \text{ RPM}$ or 911.25 RPM. Typical follower applications include synchronized rotation, synchronized conveyors, and some web-material processes.

Visual Reference

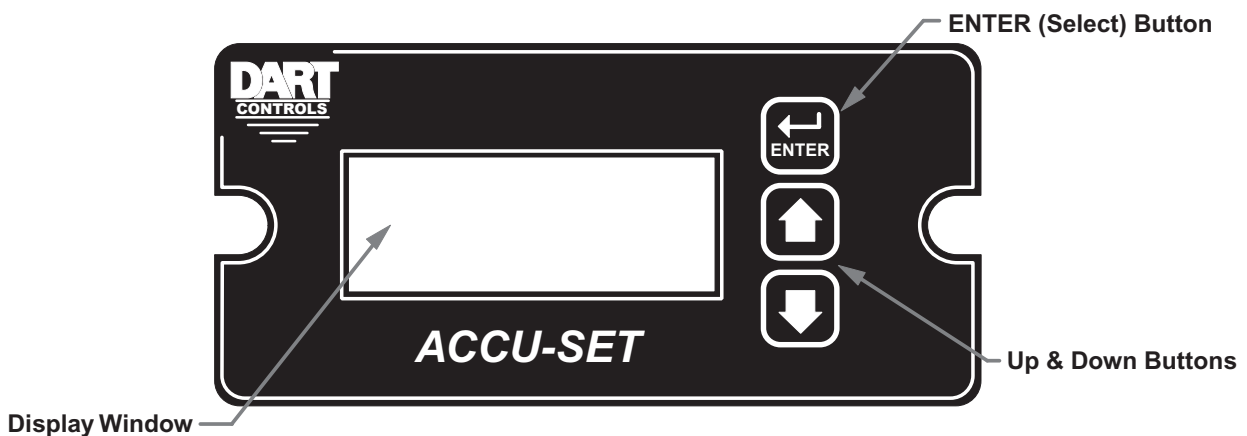

How to Change a Parameter's Value (The Short Story)

1. Hold down the Enter button until Parameter-Selection Mode is entered
2. Using the Up and Down buttons, select the desired parameter number to view or edit
3. Press the Enter button to change the value of the parameter
4. Using the Up and Down buttons, change the parameter's value as desired
5. Press the Enter button to permanently save the changes (Return to Parameter-Selection Mode)
6. Select parameter zero and press the Enter button to return to Running Mode

Operating the User Interface (The Long Story)

Although the ASP10 user interface is very versatile, it is also simple to setup and operate. With just a few button presses, it allows the user to configure a number of adjustable parameters. The LED display has three basic operating modes: Running Mode, Parameter-Selection Mode, and Value Mode. Each of the three modes have specific visual indicators that allow the user to immediately determine the current state or mode of the user interface. **Parameter-Selection Mode and Value Mode can only be entered if the Program Enable jumper is in the “On” position.**

Running Mode is the default display of the unit when power is applied. The ASP10 will spend the majority of its time in this mode. In Running Mode, the display shows the target value in the appropriate user-defined format of rate, time, or percentage. The control will continuously attempt to drive the motor at the requested target rate. In this display mode, the Up and Down buttons increase or decrease the displayed target value until either the display minimum or display maximum limit is reached. Depending on the alarm configuration, these buttons may also serve as an alarm-silence or alarm-reset button. Example displays for rate, time, and follower operating modes are 13.60, 45:30, and 9301.

Parameter-Selection Mode can be entered by simply pressing and holding the Enter button down for three seconds. Once in Parameter-Selection Mode, the far left of the display will be a 'P'. The right side of the display will indicate the currently selected parameter number for editing purposes. Pressing the Up or Down button will increase or decrease the selected parameter number on the display. Although the parameter numbers are in numerical order, some numbers are skipped. These numbers represent reserved parameters that are not yet implemented and are not displayed. Once the desired parameter number is displayed, a press of the Enter button will change the display to the Value Mode. **When in Parameter-Selection Mode, pressing the Enter button with parameter 0 selected will cause the unit to return to Running Mode.** Example displays for Parameter-Selection Mode are P 1, P 12, and P 54. See the Software Parameters for a list of available parameters.

Value Mode is used to modify the value of the selected parameter. When in Value Mode, the two dots which form the colon, between digits two and three, will alternately flash (one, then the other) to inform the user that a parameter's value is being edited. Pressing the Up or Down button increases or decreases the selected parameter's value. See the Software Parameters for a list of allowable values and ranges. Value changes take effect immediately. For example, when scrolling through the alarm output conditions, the relay will activate as the always-active selection is passed. Once the desired value is showing in the display window, pressing the Enter button again will return to Parameter-Selection Mode. The new value is not saved in permanent memory until the Enter button is pressed. Removing power from the unit while in Value Mode may result in the specified new value being lost.

Detailed Configuration Instructions

Default Configuration

When shipped from the factory, the following basic settings are in place:

Rate Mode Operation in RPM

S1 and S2 Signal Input Pulses per Revolution: 1

Decimal Point Display: Off

Display Range: 0 - 2400

Speed Range: 0 - 2400 RPM

Accel and Decel: 2500 RPM per second

Signal Input 2 (S2) Mode: Jog @ 1000 RPM when Low

User Input 1 (UIN1) Mode: Emergency Stop when Low

Alarm Output: Disabled

Resetting the Unit to Factory Defaults

The factory-default settings can be easily restored using either of two methods. Both methods require the Program Enable jumper to be in the "On" position. The first is to apply power to the unit with both the Enter and Down buttons pressed for 3 seconds. The second is to change the value of parameter 95 to 5.

JP1 (Program Enable Jumper)

The JP1 jumper is located under the dust cover on the back end of the upper board. When the jumper is set to the "Off" position, all programming features are locked out to the front panel user. When the jumper is in the "On" position, the programming parameters are open to change. JP1 is shipped from the factory set in the "On" position.

Software Parameters

Parameter	Description	Value Range (units)	Factory Default	User Settings
0	Selecting this item exits to Running Mode	n/a	n/a	
Read-Only Parameters				
1	Model Number	12 – ASP10 Unit	12	
2	Software Build	1 – 9999	n/a	
3	Hardware Version	1 – 9999	n/a	
4	Serial Number – Major (reserved)	n/a	n/a	
5	Serial Number – Minor (reserved)	n/a	n/a	
General Setup				
10	Operating Mode	1 – Rate Mode 2 – Time Mode 3 – Follower Mode	1	
11	Display Intensity	0 – 31 (Dim – Bright)	26	
13	Decimal Point Position	0 – DP Disabled (XXXX) 1 – X.XXX 2 – XX.XX 3 – XXX.X 4 – XXXX.	0	
14	Keypad Mode	1 – Linear, Constant Rate 2 – Non-linear, Accelerating Rate	2	
15	Keypad Scroll Delay	0 – 30 (Fast – Slow)	10	
16	S1 / S2 Input Edge & Prescaler Configuration	0 – S1 is Rising/1 S2 is Rising/1 1 – S1 is Falling/1 S2 is Rising/1 2 – S1 is Falling/4 S2 is Rising/1 3 – S1 is Falling/16 S2 is Rising/1 4 – S1 is Rising/1 S2 is Falling/1 5 – S1 is Falling/1 S2 is Falling/1 6 – S1 is Falling/4 S2 is Falling/1 7 – S1 is Falling/16 S2 is Falling/1 8 – S1 is Rising/1 S2 is Falling/4 9 – S1 is Falling/1 S2 is Falling/4 10 – S1 is Falling/4 S2 is Falling/4 11 – S1 is Falling/16 S2 is Falling/4 12 – S1 is Rising/1 S2 is Falling/16 13 – S1 is Falling/1 S2 is Falling/16 14 – S1 is Falling/4 S2 is Falling/16 15 – S1 is Falling/16 S2 is Falling/16	0	
18	Power-up Mode	1 – Default to Zero Display 2 – Default to Power-up Value 3 – Default to Previous Running Val.	3	
19	Power-up Value	0 – 9999 (Display Units)	0	
Display & Control Loop Setup				
20	Display Minimum	0 – 9998 (Display Units)	0	
21	Display Maximum	1 – 9999 (Display Units)	2400	
23	Accel Setting	1 – 9999 (Display Units)	2500	
24	Decel Setting	1 – 9999 (Display Units)	2500	
26	Proportional Gain	0 – 9999 (Not Unit-specific)	0	
27	Integral Gain	1 – 9999 (Not Unit-specific)	5000	
29	Pulse Accumulation Limit	2 – 5000 (Not Unit-specific)	15	
Signal Input #1 (S1) Setup				
30	S1 Display Reference	0 – 9999 (Display Units)	2400	
31	S1 Reference RPM	0 – 9999 (RPM)	2400	
32	S1 Pulses per Revolution	1 – 2048 (PPR)	1	
33	S1 Deadband (Follower Mode Only)	0 – 1000 (Seconds)	0	

Software Parameters, cont'd

Parameter	Description	Value Range (units)	Factory Default	User Settings
Signal Input #2 (S2) Setup				
35	S2 Input Configuration	1 – Disabled (Follower Mode) 2 – E-Stop When S2 High 3 – E-Stop When S2 Low 4 – Inhibit When S2 High 5 – Inhibit When S2 Low 6 – Jog When S2 High 7 – Jog When S2 Low	7	
36	S2 Setpoint	1 – 9999 (Display Units)	1000	
37	S2 Pulses per Revolution	1 – 2048 (PPR)	1	
38	Front Panel DoubleClick Mode	0 – Hardware Inhibit 1 – DoubleClick Toggles Inhibit	0	
40	Reserved			
41	Reserved			
Alarm Output Configuration				
50	Activation Conditions	0 – Always Off 1 – Always On 2 – Active when Above upper limit 3 – Active when Below lower limit 4 – Active inside Range 5 – Active outside Range 6 – Active when Target = 0 7 – Active when no Pickup Pulses detected 8 – Active when at Max. Conduction	0	
51	Output Style & Reset Mode	1 – Constant & Auto Reset 2 – Constant & Manual Reset 3 – Pulsed & Auto Reset 4 – Pulsed & Manual Reset	1	
52	Reset Configuration	1 – No Sil., Reset on Key 2 – No Sil., Reset on S2 High 3 – No Sil., Reset on S2 Low 4 – Sil., Reset on Key 5 – Sil., Reset on S2 High 6 – Sil., Reset on S2 Low	1	
53	Display Flash On Active Alarm	0 – Alarm Flash Disabled 1 – Alarm Flash Enabled	0	
54	Pulse on Time	1 – 3600 (seconds)	1	
55	Pulse off Time	1 – 3600 (seconds)	1	
56	Pulse Count	0 – 9999 (pulses)	0	
57	Lower Limit	0 – 9999 (display units)	0	
58	Upper Limit	0 – 9999 (display units)	9999	
Parameter Memory Commands				
95	Restore Settings to Factory Default	0 – Do Nothing & Exit 5 – Restore Factory Defaults	0	
98	Save to User Default Area	0 – Do Nothing & Exit 5 – Save Setting	0	
99	Restore from User Default Area	0 – Do Nothing & Exit 1 – Restore Settings	0	

Parameter Descriptions

Parameter 0 – Exit to Running Mode

When parameter 0 is selected in Parameter-Selection Mode, the unit will return to Running Mode and display the running value. This should be selected once changes to parameters are completed.

Parameter 1 – Model Number (Read Only)

This is a number which represents the base model number for the product. The model code for the ASP10 is 12.

Parameter 2 – Software Build (Read Only)

The software build is a code which identifies the software version of the unit.

Parameter 3 – Hardware Version (Read Only)

The hardware version is a code which identifies which hardware was used to build the unit.

Parameter 4 & 5 – Serial Number, Major & Minor (Read Only)

These parameters are reserved for future use as an electronic serial number and are unique to each manufactured unit.

Parameter 10 – Operating Mode

This parameter defines the operating mode for the entire unit. There are two basic modes of operation, master and follower. In master modes, the unit controls the load using either rate or time units. In follower mode, the unit controls the load in percentage of master rate. The following modes are available for the ASP10:

Mode 1 – Master, Rate Mode

In Rate Mode, the ASP10 displays in user-defined rate units such as RPM, Gallons per Hour, or Feet per Second. See applications for examples.

Mode 2 – Master, Time Mode

In Time Mode, the ASP10 displays in time units using the format AA:BB. By default AA:BB represents minutes (AA) and seconds (BB). Optionally, it can be configured to represent hours (AA) and minutes (BB) or other user-defined units with a 1:60 relationship. When setting parameters which are configured in display units, the programmed value is the determined by the formula $(AA * 60) + BB$. In HH:MM displays, this is the total number of minutes. In MM:SS displays, this is the total number of seconds. See applications for examples.

Mode 3 – Follower Mode

In Follower Mode, the ASP10 displays in percentage units, where 1000 equals 100.0 percent of the master rate. For example, if the display indicates 985, 98.5, or 9.85, the ASP10 will attempt to run at exactly 98.5 percent of the master rate. Display settings are always entered ignoring the decimal point's position. See applications for more examples.

Parameter 11 – Display Intensity

This parameter adjusts the intensity of the LED display digits in the front panel of the unit. The values of 0 – 31 correspond to a gradual change from very dim to very bright. This is often useful when the ASP10 is used in the same panel as other pieces of equipment with LED displays and a uniform display brightness is desired. Simply adjust the ASP10 to match its surroundings.

Parameter 13 – Decimal Point (DP) Position

This selects the format of the display with respect to the decimal point's position. This parameter does not effect the value entry for other parameters. For example, if the user desires to display 10.00 at 300RPM, then parameter 30 would be set to 1000, parameter 31 would be set to 300, and parameter 13 would be set to 2.

Mode 0: Fixed XXXX

Mode 1: Fixed X.XXX

Mode 2: Fixed XX.XX

Mode 3: Fixed XXX.X

Mode 4: Fixed XXXX.

Parameter 14 – Keypad Mode

This parameter selects the operating mode of the front-panel push buttons. In some applications, increasing or decreasing the scroll rate provides the user more controllability when entering settings. Parameters 14 and 15 affect only the Up and Down buttons when the user interface is in Running Mode. These settings also apply to remote Up / Down buttons which are attached via the -1 option board.

Mode 1: Linear, Constant Rate

In linear mode, pressing and holding the Up or Down buttons will cause the display to continuously change value in the requested direction until either the Display Minimum or Display Maximum is reached. The displayed value will scroll at a constant rate which is specified using parameter 15.

Mode 2: Non-linear, Accelerating Rate

In non-linear mode, pressing and holding the Up or Down buttons will cause the display to continuously change value in the requested direction until either the Display Minimum or Display Maximum is reached. The displayed value will initially scroll at a slow rate and increase in speed until the maximum scroll rate is achieved. The initial scroll rate is specified using parameter 15.

Parameter 15 – Keypad Scroll Mode

This parameter sets the scroll speed for the front-panel push buttons. The function of this parameter varies slightly depending on the Keypad Mode. See parameter 14 for more details.

Parameter 16 – S1 / S2 Input Edge & Prescaler Configuration

This parameter determines how the ASP10 processes the S1 and S2 signal inputs. It specifies which signal edge is used for measurements and the value of the internal frequency dividers or prescalers. Modes with prescalers greater than 1 should only be used if the input pulse rate on S1 or S2 exceeds the unit's maximum native pulse rate (see specifications for details); otherwise, the control loop may become sluggish and unnecessarily inaccurate. Use the following chart to configure this parameter. As an example, assume an application requires input pulse rates on S1 of 120,000 pulses-per-minute and S2 of 35,000 pulses-per-minute. According to the electrical specifications, the unit can only accept 50,000 pulses-per-minute on each the S1 and S2 inputs. With this in mind, the S1 and S2 prescalers should be selected as Falling / 4 and Rising / 1, respectively. In this case, parameter 16 would be set to 2.

Selection Chart		S1 Input Edge and Prescaler			
		Rising / 1	Falling / 1	Falling / 4	Falling / 16
S2 Input Edge and Prescaler	Rising / 1	0	1	2	3
	Falling / 1	4	5	6	7
	Falling / 4	8	9	10	11
	Falling / 16	12	13	14	1

Parameter 18 – Power-up Mode

This parameter defines the mode which determines the default Running Value when power is initially applied to the ASP10.

Mode 1: Default to Zero

When in this mode, the unit will default to zero (display units).

Mode 2: Default to Power-Up Value

When in this mode, the unit will default to the Power-up Value, parameter 19.

Mode 3: Default to Previously Running Value

When in this mode, the unit will default to the previous running value before power was removed. *A previous running value must have been active for at least 3 seconds to be recalled after power has been disconnected and reapplied.*

Parameter 19 – Power-up Value

When Power-up Mode is set to 2, this parameter will designate the default display value at power-up in display units.

Parameter 20 – Display Minimum

This parameter defines the lower end of the display range. This is the value which limits how low the user is able to scroll the displayed value in Running Mode. In Rate and Time modes, this value is set in display units. In Follower Mode, this is set in percentage of the master rate. For example, in Follower Mode, 1250 represents 125.0 percent of the master rate.

Parameter 21 – Display Maximum

This parameter defines the upper end of the display range. This is the value which limits how high the user is able to scroll the displayed value in Running Mode. In Rate and Time modes, this value is set in display units. In Follower Mode, this is set in percentage of the master rate. For example, in Follower Mode, 150 represents 15.0 percent of the master rate.

Parameter 23 – Acceleration Setting

This parameter determines how fast the ASP10 will accelerate toward the displayed target setting. This parameter is set in display units of change per second such as RPM, GPM, or feet per second. In Follower Mode, this parameter is set in RPM units.

Parameter 24 – Deceleration Setting

This parameter determines how fast the ASP10 will decelerate toward the displayed target setting. This parameter is set in display units of change per second such as RPM, GPM, or feet per second. In Follower Mode, this parameter is set in RPM units.

Parameter 26 – Proportional (P) Gain

The Proportional Gain is the first of two parameters which define the responsiveness of the control with respect to how fast it responds to changing loads. Because the ASP10 is a pulse-accumulation drive, the P Gain responds differently than the same parameter in a standard velocity-form PID control. The higher the P Gain, the more aggressively the unit will drive the load. See the PI Control Tuning section of the manual for more details.

Parameter 27 – Integral (I) Gain

The Integral Gain is the second of two parameters which define the responsiveness of the control with respect to how fast it responds to changing loads. The higher the I Gain, the more aggressively the unit will drive the load. When using high PPR pickups or encoders, it will be necessary to decrease the I Gain to prevent unwanted oscillation and instabilities. See the PI Control Tuning section of the manual for more details.

Parameter 29 – Pulse Accumulation Limit

This parameter sets the limit for the maximum number of pulses the drive will accumulate prior to intentionally losing count and therefore long-term accuracy. Because the ASP10 is a pulse-accumulation drive, it is able to accurately track a master (in Follower Mode) pulse-by-pulse. That is, the ASP10 is able to run for days, weeks, or months and remain completely in sync with a master drive or process; unfortunately, this functionality comes at a small cost.

By default, if the main pickup signal were lost and then reattached, the unit may run at high speeds for many seconds while attempting to make-up what would have been lost pulses. Once it catches up, it returns to normal operation. In some applications, this is a nuisance. In these cases, the Pulse Accumulation Limit, parameter 29, can be lowered to limit the maximum number of pulses the drive will remember.

This parameter is set from 0 to 9999, where 0 is no accumulation and 9999 is maximum accumulation. As this value approaches zero, the unit will gradually lose its ability to drive the motor and eventually stop the motor completely. It may be necessary to increase the value of this parameter for application which demand higher long-term accuracy.

Parameter 30 – Signal Input 1 (S1) Display Reference

This is the number to be displayed when at the user-specified motor Reference RPM. In Rate Mode, this value represents rate units such as feet, ounces, or revolutions. In Time Mode, this value represents the reference time measured in seconds or minutes. If the desired display is HH:MM, then all values should be entered in minutes. If MM:SS is desired, then all values should be entered in seconds. In Follower Mode, this value is the percentage of the master rate in 0.1% units. For example, 1000 equates to 100%. See applications for more examples.

Parameter 31 – Signal Input 1 (S1) Reference RPM

This is the reference RPM at which the Display Reference value should be displayed. In Rate and Time Modes, this value represents the RPM of the encoder to which the Display Reference corresponds. In Follower Modes, this value is not used. See applications for examples.

Parameter 32 – Signal Input 1 (S1) Pulses per Revolution

This is the number of pulses per revolution for the signal input 1 (S1). The ASP10 supports pickups and encoders from 1 to 2048 pulses per revolution.

Parameter 33 – Signal Input 1 (S1) Deadband (Follower Mode Only)

When in Follower Mode, it is often desirable for the follower unit to continue to slowly make-up the small pickup pulse differential between the master and follower's position. In some applications, it is not necessary for the follower to continue to slowly seek the master's exact pulse position when the master rate is at zero. In these cases, the Deadband parameter can be set above zero to force the ASP10 to stop driving the motor slowly and cause it to inhibit until the master starts rotating again. At that point, the follower will automatically make-up the pulse differential as it starts to rotate. The deadband is disabled by setting it to zero seconds.

Parameter 35 – Signal Input 2 (S2) Input Configuration

This parameter determines the operating mode of signal input 2 (S2).

Mode 1: Disabled (Follower Mode)

The S2 input is inactive. This is the required setting for Follower Mode.

Mode 2: Emergency Stop When S2 High (Not Wired To Common)

When the S2 input is at an electrically high (+5V) state or allowed to float disconnected, the ASP10 will enter emergency-stop mode. While in this mode, the output will immediately be turned off. Once the S2 input returns to an electrically low state or wired to the unit's common, the output will become active.

Mode 3: Emergency Stop When S2 Low (Wired To Common)

When the S2 input is at an electrically low state or wired to the unit's common, the ASP10 will enter emergency-stop mode. While in this mode, the output will immediately be turned off. Once the S2 input returns to an electrically high (+5V) state or allowed to float disconnected, the output will become active.

Mode 4: Inhibit When S2 High (Not Wired To Common)

When the S2 input is at an electrically high (+5V) state or allowed to float disconnected, the ASP10 will enter inhibit mode. While inhibited, the output will decrease according to the decel setting until zero output is reached. Once the S2 input returns to an electrically low state or is wired to the unit's common, the output will start to accelerate toward the previous running value.

Mode 5: Inhibit When S2 Low (Wired To Common)

When the S2 input is at an electrically low state or wired to the unit's common, the ASP10 will enter inhibit mode. While inhibited, the output will decrease according to the decel setting until zero output is reached. Once the S2 input returns to an electrically high (+5V) state or allowed to float disconnected, the output will start to accelerate toward the previous running value.

Mode 6: Jog When S2 High (Not Wired To Common)

When the S2 input is at an electrically high (+5V) state or allowed to float disconnected, the ASP10 will enter jog mode. While in jog mode, the display will immediately change to the programmed jog setpoint, parameter 36. The unit will start accelerating or decelerating toward the jog setting at the configured accel and decel rates. Once the S2 input returns to an electrically low state or is wired to the unit's common, the output will start to accelerate or decelerate toward the previous running value. In Follower Mode, the unit will operate as its own master. This allows an application to jog by overriding a stopped master.

Mode 7: Jog When S2 Low (Wired To Common)

When the S2 input is at an electrically low state or wired to the unit's common, the ASP10 will enter jog mode. While in jog mode, the display will immediately change to the programmed jog setpoint, parameter 36. The unit will start accelerating or decelerating toward the jog setting at the configured accel and decel rates. Once the S2 input returns to an electrically high (+5V) state or allowed to float disconnected, the output will start to accelerate or decelerate toward the previous running value. In Follower Mode, the unit will operate as its own master. This allows an application to jog by overriding a stopped master.

Parameter 36 – Signal Input 2 (S2) Setpoint

When the S2 configuration, parameter 35, is set to one of the jog modes, this parameter defines the jog setpoint in display units. If the ASP10 operating mode is set to Follower Mode, then this parameter is set in RPM units. This allows a follower control to be jogged when the master is stopped.

Parameter 37 – Signal Input 2 (S2) Pulses per Revolution

This is the number of pulses per revolution for the signal input 2 (S2). The ASP10 supports pickups and encoders from 1 to 2048 pulses per revolution.

Parameter 38 - Front Panel DoubleClick Mode

When set to a value of 1, the setting of Parameter 35 and/or Parameter 40, particularly Modes 4 and 5 (Inhibit), have no effect; instead, "clicking" the ENTER Button twice in rapid succession ("Double-Clicking") will TOGGLE the MD10P/3P in and out of "Inhibit" mode. When in DoubleClick mode, the Motor will decelerate to a stop, and the Display will show 4 dashes

"----" DoubleClicking again will cause the motor to accelerate up to the Target speed/time, and the Display to return to its normal condition. When set to a value of Zero, the Inhibit function is controlled exclusively by the signal level on the S2 and/or UIN1 Input(s), and the setting of Parameters 35 and/or 40, and the "DoubleClick" function will have no effect. Note also that the DoubleClick Inhibit is only honored in "Run" mode.

Parameter 40 – Reserved

Parameter 41 – Reserved

Parameter 50 – Alarm 1 Conditions

This defines which conditions will result in the alarm 1 output being activated.

Mode 0: Always Inactive

The alarm output will remain in an inactive state. In this state, the NC and C contacts will be internally electrically connected.

Mode 1: Always Active (When Power Is Applied)

The alarm output will become active when the power is applied to the unit. In this state, the NO and C contacts will be internally electrically connected.

Mode 2: Active When Display Value Above Limit

The alarm output will activate when the displayed value is above the upper limit setting, parameter 48.

Mode 3: Active When Display Value Below Limit

The alarm output will activate when the displayed value is below the lower limit setting, parameter 47.

Mode 4: Active When Display Value Inside Range

The alarm output will activate when the displayed value is greater than or equal to lower limit settings and less than or equal to the upper limit setting.

Mode 5: Active When Display Value Outside Range

The alarm output will activate when the displayed value is less than the lower limit setting or greater than upper limit setting.

Mode 6: Active When Target (Display) = Zero

The alarm output will activate when the displayed value is equal to zero. This allows the alarm output to be used to drive a mechanical brake to decrease stopping time or to provide holding torque at zero speed.

Mode 7: Active When Main Pickup Signal (S1) Stalled or stopped

The alarm output will activate when the main pickup signal input (S1) has stalled or stopped. The alarm lower limit (Parameter 57) is used to specify the stall timeout, in seconds, under a motor stall condition. When using the lower limit to set the stall timeout, an inhibit command or zero speed command will not be recognized as a stall condition. The pickup is considered to have stalled if the timeout passes with no pickup pulses when the target (displayed) value is greater than zero and the control has not been given an inhibit command. The alarm upper limit (Parameter 58) is used to specify a zero speed or stopped timeout condition in seconds. When using the upper limit to set a zero speed or stopped timeout, an inhibit command, a zero speed command or a motor stall condition will all be recognized as a stopped condition. The pickup is considered to have stopped after the timeout passes with no pickup pulses.

Note: When using the upper limit to set a stopped timeout the lower limit should be set to zero.

Mode 8: Active When Driving At Maximum Conduction Angle

The alarm output will activate when the control is driving the motor at the maximum conduction angle. This can be used to determine if the control is running away due to a broken pickup signal wire when stall-detection is not desired.

Parameter 51 – Alarm 1 Output Style & Reset Configuration

This setting configures the output mode and reset method for the alarm output.

Mode 1: Constant & Auto Reset

In this mode, the alarm output will remain active until the alarm condition ceases to exist. The alarm will automatically reset when the conditions return to normal.

Mode 2: Constant & Manual Reset

In this mode, the alarm output will remain active until the alarm is reset manually. See parameter 52 for details.

Mode 3: Pulse & Auto Reset

In this mode, the alarm output will pulse on and off until the alarm condition ceases to exist. The pulsed modes are commonly used for audible alarms where a constant output would be considered distracting or awkward. The alarm will automatically reset when the conditions return to normal.

Mode 4: Pulse & Manual Reset

In this mode, the alarm output will pulse on and off until the alarm is reset manually. See parameter 52 for reset details. The pulsed modes are commonly used for audible alarms where a constant output would be considered distracting or awkward.

Parameter 52 – Alarm 1 Reset Configuration

This setting determines which actions will cause an active alarm to be silenced or reset.

Mode 1: No Silencing, Reset On Any Button Press

In this mode, an active alarm cannot be silenced. Once the alarm condition ceases to exist, however, any user-interface button may be pressed to cause a manual reset.

Mode 2: No Silencing, Reset On S2 Input High (Not Wired To Common)

Similar to Mode 1. Once the alarm condition ceases to exist, setting the S2 input to a high (+5V) state or allowing it to float disconnected will cause a manual reset.

Mode 3: No Silencing, Reset On S2 Input Low (Wired To Common)

Similar to Mode 1. Once the alarm condition ceases to exist, setting the S2 input to a low (COM) state or wiring it to common will cause a manual reset.

Mode 4: Silencing Enabled, Reset On Any Button Press

When the conditions for an active alarm persist, pressing any user-interface button will result in the alarm being silenced or deactivated, but not reset. A second attempt to reset the alarm must be made after the condition ceases to exist to clear the alarm.

Mode 5: Silencing Enabled, Reset On S2 Input High (Not Wired To Common)

Similar to Mode 4. Setting the S2 input to a high (+5V) state or allowing it to float disconnected will cause the alarm to be silenced or reset depending on the current state of the alarm conditions.

Mode 6: Silencing Enabled, Reset On S2 Input Low (Wired To Common)

Similar to Mode 4. Setting the S2 input to a low (COM) state or wiring it to common will cause the alarm to be silenced or reset depending on the current state of the alarm conditions.

Parameter 53 – Alarm 1 Display Flash On Alarm

This will cause the display to flash when an alarm condition is active.

Parameter 54 – Alarm 1 Pulse on Time

This parameter defines the number of seconds the output should be enabled during the 'on' phase of an active pulsing alarm's output.

Parameter 55 – Alarm 1 Pulse off Time

This parameter defines the number of seconds the output should be disabled during the 'off' phase of an active pulsing alarm's output.

Parameter 56 – Alarm 1 Pulse Count

This setting determines how many pulses are output when the alarm is activated and is configured in pulse output style. *When 0 is entered, the unit will be set for continuous pulses while the alarm is active.*

Parameter 57 – Alarm 1 Lower Limit

This setting defines either the lower limit, the lower end of a range for the alarm region or a stall timeout. Alarm limits are set in display units without regard to decimal point or colon position. In Rate and Follower Modes, a limit of 123 could represent a display value of 123, 12.3, 1.23, or 0.123. When in Time Mode, a limit of 123 would represent 1:23 on the display. When the lower limit is being used to set a stall timeout for parameter 50 mode 7, the setting is in seconds.

Parameter 58 – Alarm 1 Upper Limit

This setting defines either the upper limit, the upper end of a range for the alarm region or a stop timeout. Alarm limits are set in display units without regard to decimal point or colon position. In Rate and Follower Modes, a limit of 123 could represent a display value of 123, 12.3, 1.23, or 0.123. When in Time Mode, a limit of 123 would represent 1:23 on the display. When the upper limit is being used to set a stop timeout for parameter 50 mode 7, the setting is in seconds.

Parameter 95 – Factory Default Command

When set to a value of 5, the unit will be reset to factory default settings. This can also be achieved by applying power to the unit with both the Enter and Down buttons depressed. *The programming jumper must be in the "On" position for this method to function.*

Parameter 98 – Save to User Default Area Command

When set to a value of 5, the unit will store all adjustable parameters to the user default area. The user default area is intended to be a location where an OEM or integrator can store settings specific to their application. Using this, an OEM can easily refresh their custom settings in the field if an end-user accidentally reconfigures the unit unsuccessfully. Another common use for this area is testing and initial setup. The user can store known-good settings here and easily experiment without the fear of losing the optimal configuration.

Parameter 99 – Restore from User Default Area Command

When set to a value of 1, the unit will restore all adjustable parameters from the user default area. See parameter 98 for additional information.

Application Examples

Pump Controller with Audible and Visual Alarm

Description:

A waste pump control which displays the pump rate in liters per minute with an audible and visual alarm output which will warn the operator if the waste flow has stopped. The alarm should not be able to be silenced and should automatically reset when flow rates have returned to normal. The display should indicate in the format "xxx.x" (LPM).

Application Diagram:

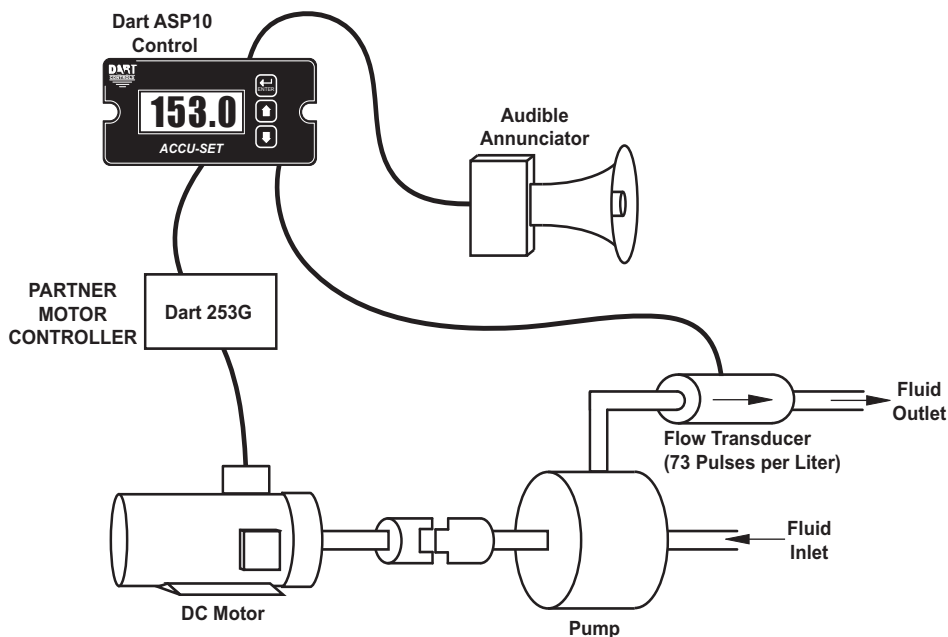

Pump Specs:
19 Shaft Rotations = 2 Liters

Wiring Diagram:

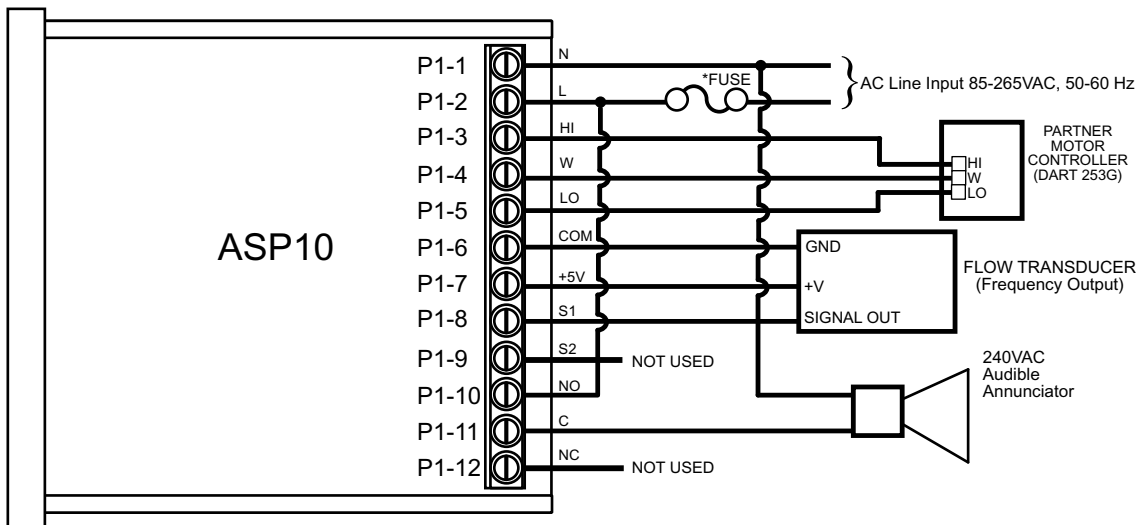

* Size fuse according to unit and application. See electrical specifications for maximums.

Parameter Configuration:

Parameter	Value	Notes
10	1	Master, Rate Mode Setting (LPM is a rate-based unit)
13	3	Decimal point position set to XXX.X on display
30	10	Display should indicate 1.0 LPM (10) when pickup at Reference RPM, parameter 31
31	73	This is the RPM at which the Display Reference, parameter 30, should be displayed
32	1	Pulses per revolution of shaft encoder or pickup is 1 PPR
50	7	Alarm active when pickup stalled
53	1	Flash display when alarm is active
57	10	Lower limit setting for pickup stall timeout. Set for 10 seconds

Conveyor Oven Controller with Two Preset Process Times

Description:

An oven monitor displaying the “tunnel” time in minutes and seconds. The tunnel time is defined as the time it takes for the heated object on the conveyor to travel from point A to point B in the application diagram below. An external time-select switch should allow the user to choose between the displayed process time or a second fixed process time. The time should be displayed in MM:SS (minutes:seconds) format. The process time should only be allowed to be adjusted between 6:30 and 12:15.

Application Diagram:

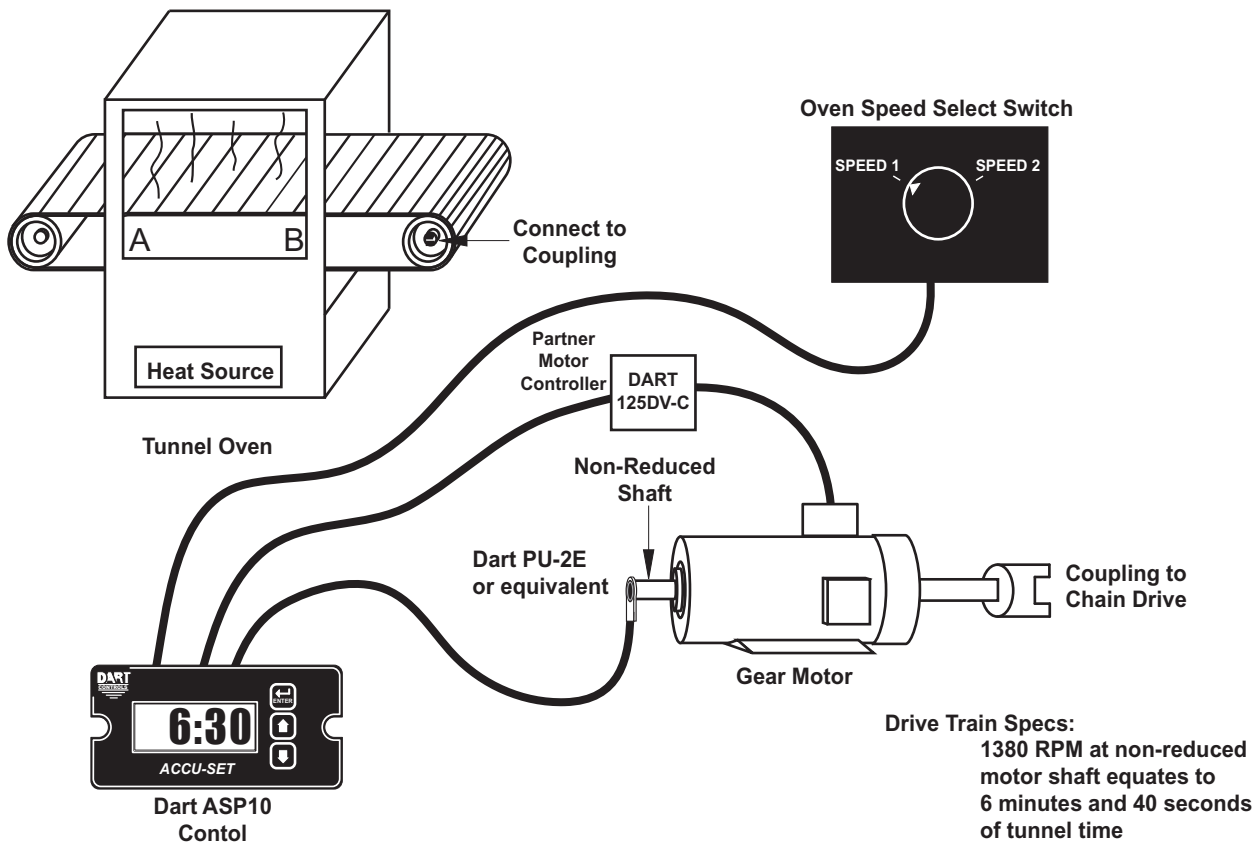

Wiring Diagram:

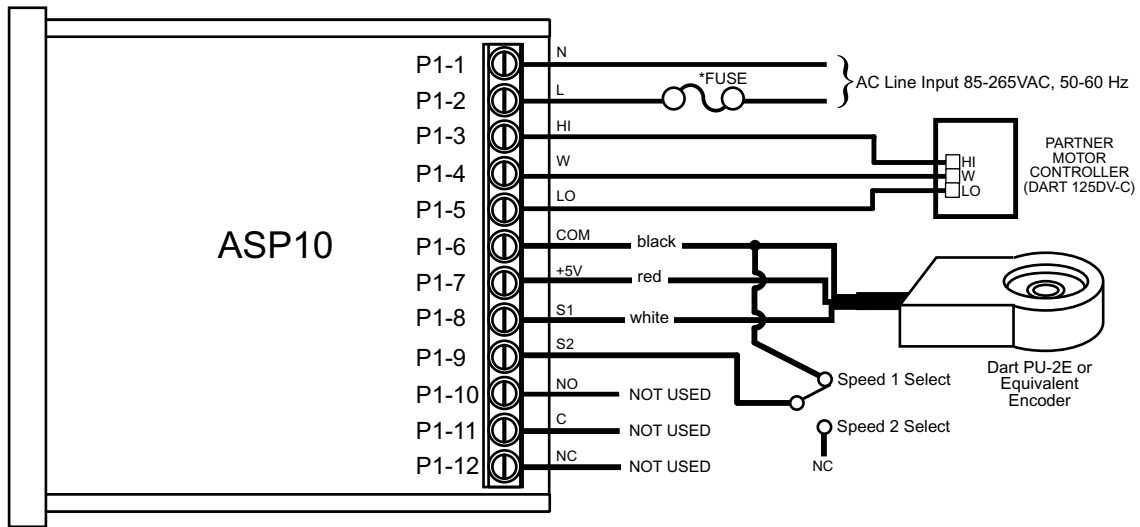

* Size fuse according to unit and application. See electrical specifications for maximums.

Parameter Configuration:

Parameter	Value	Notes
10	2	Time Mode Setting (MM:SS is a time-based unit)
20	390	Display minimum set to 6:30 (MM:SS) For example: 6 minutes * 60 seconds-per-minute + 30 seconds = 390 seconds
21	735	Display maximum set to 12:12 (MM:SS) For example: (12 minutes * 60 seconds-per-minute) + 15 seconds = 735 seconds
30	400	Display should indicate 6:40 (MM:SS) when motor at Reference RPM, parameter 31 For Example: (6 minutes * 60 seconds-per-minute) + 40 seconds = 400 seconds
31	1380	This is the RPM at which the Display Reference, parameter 30, should be displayed
32	1	Pulses per revolution of shaft encoder or pickup is 1 PPR
35	7	Set S2 input mode to jog when low
36	530	Set fixed process time during job to 8:50 (MM:SS) For example: (8 minutes * 60 seconds-per-minute) + 50 seconds = 530 seconds

Synchronized Conveyor Controller with Jog Switch

Description:

A synchronized conveyor system comprised of two conveyors with no mechanical linkage between them. The master conveyor is driven by a basic Dart analog DC motor control. The slave or follower conveyor should follow the master's position with exacting long-term accuracy. The slave conveyor should be able to be jogged into position when the master is stopped at a rate of 350 RPM. The slave conveyor may be adjusted from 90.0% to 110.0% of the master conveyor rate using the user interface.

Application Diagram:

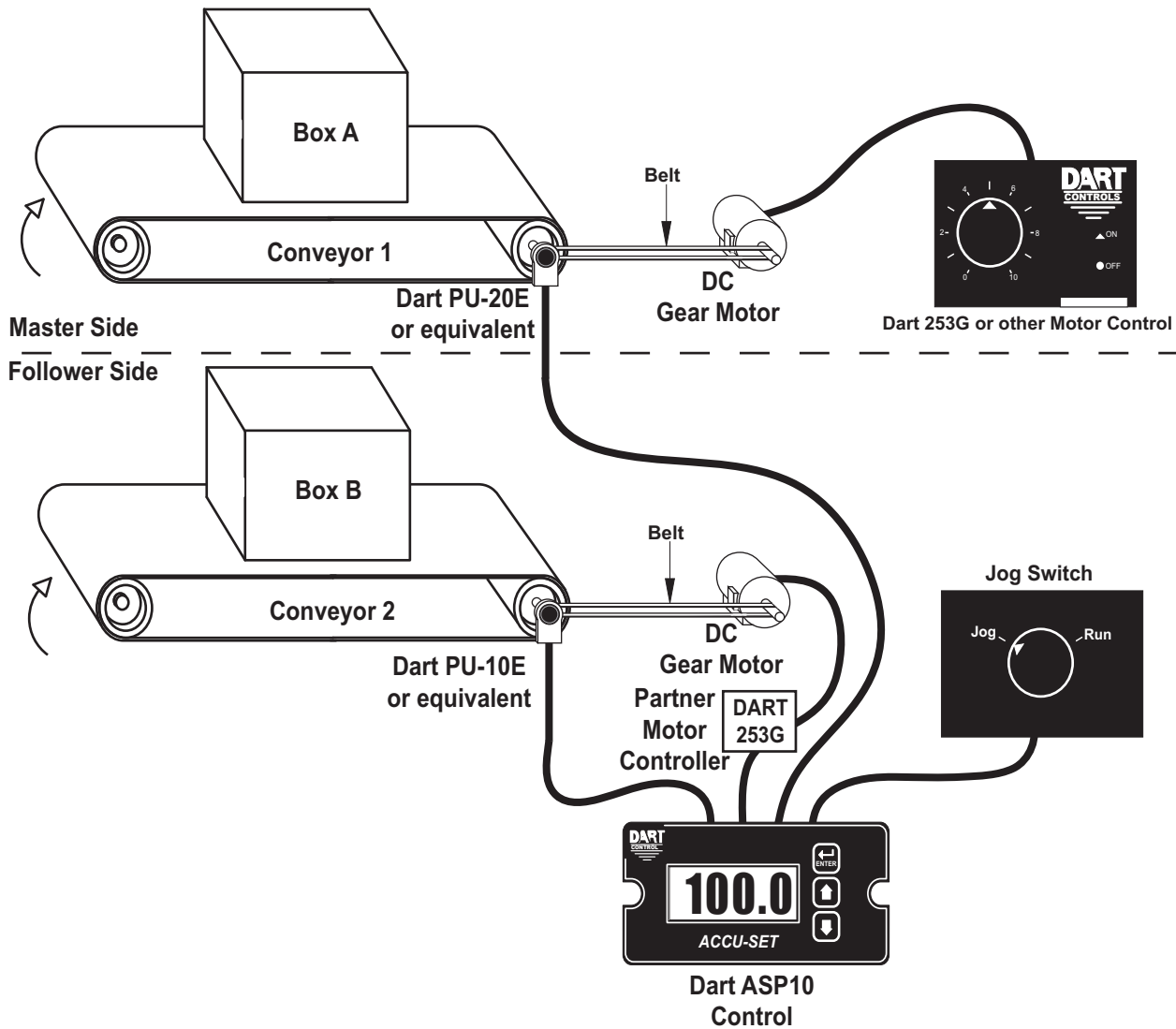

Wiring Diagram:

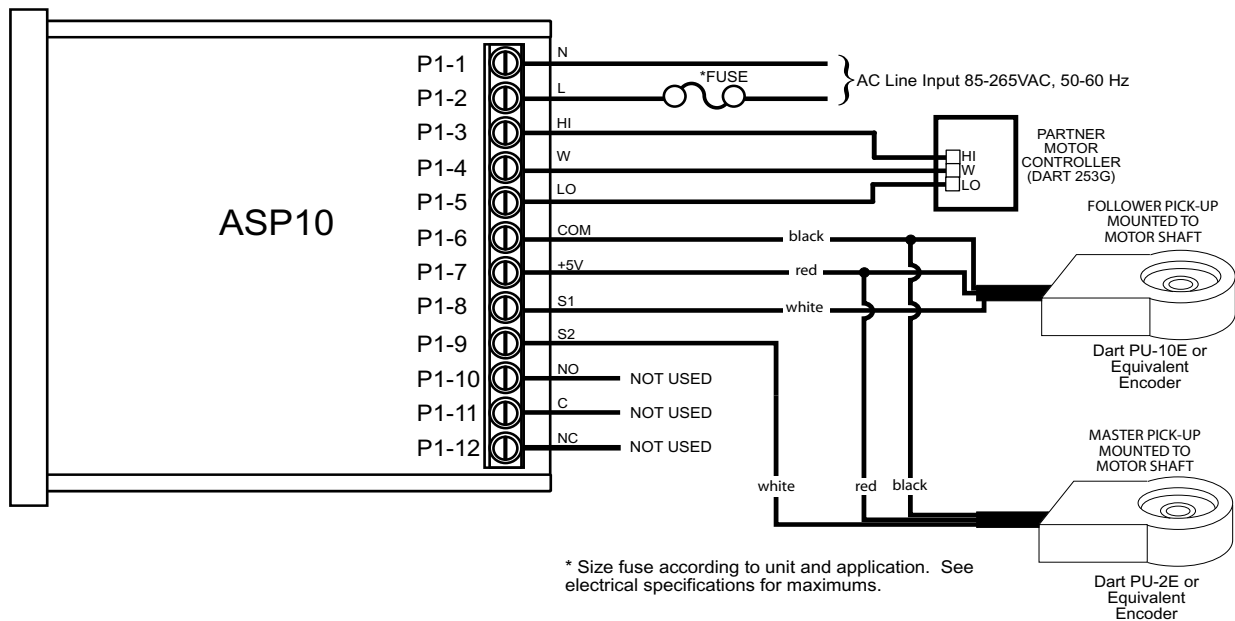

Parameter Configuration:

Parameter	Value	Notes
10	3	Follower Mode Setting
13	3	Decimal point position set to XXX.X on display
20	900	Display minimum is 90.0% of master rate
21	1100	Display maximum is 110.0% of master rate
32	5	Pulses per revolution of shaft encoder or pickup is 5 PPR
37	10	Pulses per revolution of shaft encoder or pickup is 10 PPR

Troubleshooting

Problem	Possible Case	Solution
Display is blank	Power not applied	Using a volt meter, verify that a voltage between 85 and 265VAC is measured between the L and N terminal block positions.
	Defective unit	Contact technical support for additional help and instructions.
Display is dim	Display intensity parameter is too low	Editing and increasing the display intensity parameter should cause the display digits to become brighter.
When power is applied, "LF-L" is displayed	AC line supplying power to unit has too much noise	Review routing of power wires in machine to minimize electrical noise. Look for other devices which share the same circuit which may be producing unacceptable levels of line noise. In some applications, such as welding equipment, a careful regiment of applying an AC line filter, re-routine wires, dividing circuits, using shielded cable, and properly grounding devices will usually solve the problem.
	AC line supplying power to unit has an abnormally low frequency	The unit is designed to operate with AC lines from 48-62 Hertz (cycles per second). This is typically not a problem because the international standards are 50 and 60 Hertz.
When power is applied, "LF-H" is displayed	AC line supplying power to unit has too much noise	Review routing of power wires in machine to minimize electrical noise. Look for other devices which share the same circuit which may be producing unacceptable levels of line noise. In some applications, such as welding equipment, a careful regiment of applying an AC line filter, re-routine wires, dividing circuits, using shielded cable, and properly grounding devices will usually solve the problem.
	AC line supplying power to unit has an abnormally high frequency	The unit is designed to operate with AC lines from 48-62 Hertz (cycles per second). This is typically not a problem because the international standards are 50 and 60 Hertz.
The alarm output does not seem to function	Alarm output parameters not configured properly	Alarm output parameters not configured properly Review alarm output parameters. The alarm relay output can be tested by selecting the "Always On" value for the Activation Condition parameters for the alarm output. When doing this, the relay click should be audible and the NC (Normally Closed) and C (Common) terminals should become internally shorted at the terminal block.

Technical Support Options

- Visit the Dart Controls Web Site at: www.dartcontrols.com
- Email technical support at: techsupport@dartcontrols.com
- Telephone technical support at 317-733-2133 ext. 4

What's Special About www.dartcontrols.com?

- Changes to printed material and product offerings first appear online
- Product manuals and other literature are easily accessible

REPAIR PROCEDURE

In the event that a Product manufactured by Dart Controls Incorporated (DCI) is in need of repair service, it should be shipped, freight paid, to: Dart Controls, Inc., 5000 W. 106th Street, Zionsville, IN. 46077, ATTN: Repair Department. Please include Name, Shipping Address (no P.O. Box), Phone Number and if possible, e-mail address.

Those orders received from anyone without an existing account with DCI must specify if they will be paying COD or Credit Card (Master Card/Visa/American Express). This information is required before work will begin. If you have an account with Dart your order will be processed according to the terms listed on your account. Products with Serial Number date codes over 5 years old will automatically be deemed Beyond Economical Repair (BER). A new, equivalent device will be offered at a substantial discount.

Completed repairs are returned with a Repair Report that states the problem with the control and the possible cause. Repair orders are returned via UPS Ground unless other arrangements are made. If you have further questions regarding repair procedures, contact Dart Controls, Inc. at 317-873-5211.

YOUR MOTOR SPEED CONTROL SOLUTION PROVIDER

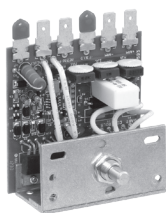

OEM Chassis SCR Drives
Dual Input voltage, adjustable HP range, isolated signal follower and reversing options

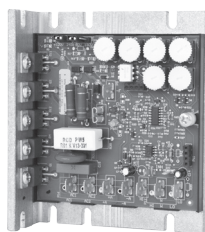

NEMA 4/4X SCR Drives
Dual Input voltage, adjustable HP range, isolated signal follower and reversing options

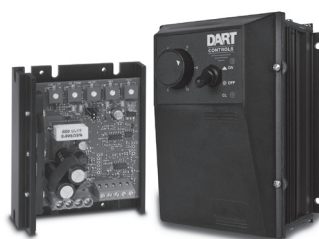

Low Voltage/Battery PWM Drives
Chassis and NEMA 4X versions, speed pot and signal follower operation



Digital SCR Drives
Closed loop accuracy, 4-20mA and serial communications, integral programmable display



Brushless DC Drives
Closed loop accuracy, line and low voltage versions through 1 HP



Digital Accessory & Resale Items

Motors to 700 HP, VFD's to 200 HP, NEMA rated encoder, digital programmable potentiometers and tachometers

Dart Controls, Inc. is a designer, manufacturer, and marketer of analog and digital electronic variable speed drives, controls, and accessories for AC, DC, and DC brushless motor applications.

Shown above is just a sampling of the expanded line of Dart controls that feature the latest in electronic technology and engineering. Products are manufactured in the U.S.A. at our Zionsville (Indianapolis, Indiana)

production and headquarters facility - with over 2,000,000 variable speed units in the field.

In addition to the standard off-the-shelf products, you can select from a wide variety of options to customize controls for your specific application. For further information and application assistance, contact your local Dart sales representative, stocking distributor, or Dart Controls, Inc.

Dart Controls, Inc.

Manufacturer of high quality DC and AC motor speed controls and accessories since 1963.

5000 W. 106th Street
Zionsville, Indiana 46077
Phone: (317) 873-5211
Fax: (317) 873-1105

www.dartcontrols.com
ISO9001 REGISTERED
MADE IN USA