

Speed Sensors

Dart Controls offers a variety of speed sensor products not only for use with drives and tachometers that require them, but for many other applications as well. The PU Series is designed and built by Dart - the other offerings are from manufacturers built to Dart's specifications.

The PU Series is very popular for its simplicity, efficiency and rugged design. Installation is simple - drill and tap a target shaft and you're done. Dirty, dusty, wet (wash down), and extreme outdoor conditions are not an issue for the PU Series. With the PU-E Series (indoor) and PU-R Series (outdoor / wash down), the user can find the right sensor for the application. The PU Series is sold worldwide on a wide variety of applications where reliable and cost-effective speed sensing is needed.

For applications where location of an accessible shaft is difficult or more pulses/revolution are needed, Dart also offers a variety of sensors that rely on different sensing technologies. These include the CF Series (hall-effect motor C-face mount and the OPU (optical).

With this sensor lineup, customers are able to monitor actual motor speed, verify motor rotation and determine location of motor driven devices such as spray application heads and material handling system carriers. Signals are fed to closed loop motor drives (MD/ASP Series from Dart), plc's and SCADA systems.



PU-E Series



PU-R Series

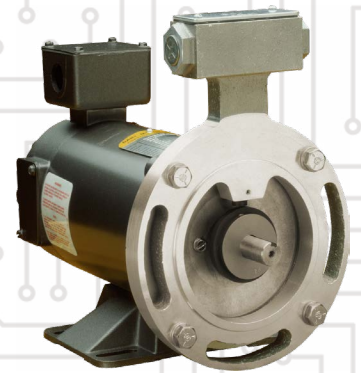

CF Series

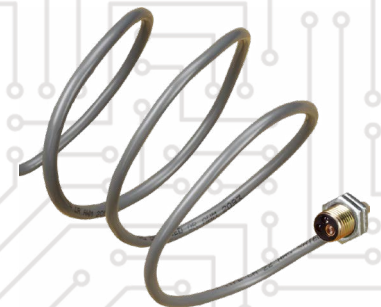

OPU Series

RoHS

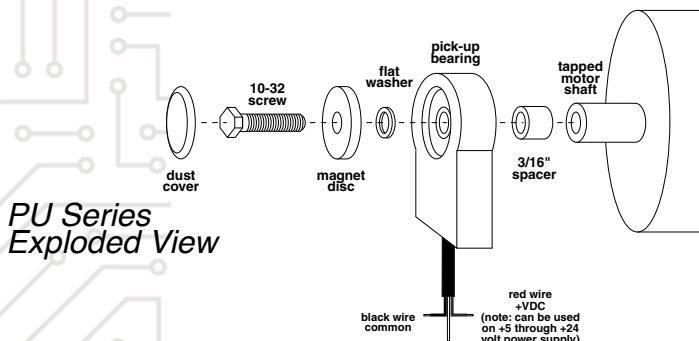

Sensor Features + Specifications

PU Series

- Single screw installation - no alignment needed
- For shaft speeds up to 5000 RPM
- 6' cable provided - may be extended to 300'^{*}
- Supply voltage +4.5 to +30VDC (see below)
- 1 to 20 pulse/revolution output
- NPN and PNP output - NPN sinks 50mA max (see below)
- -40°C to +100°C ambient temperature range
- Indoor and outdoor/wash down rated models
- Santoprene injection molded head

Model	Width	Length	Depth	Weight
PU Series (head)	1.60 in [4.06 cm]	2.40 in [6.10 cm]	0.93 in [2.36 cm]	8.8 oz [249 gm]
CF Series	[Std. C Face ¹]	9.38 in [23.83 cm]	0.75 in [1.91 cm]	2.65 lb [1.2 kg]
OPU	0.50 in [1.27 cm]	0.75 in [1.91 cm]	N/A	6 oz [170 gm]

¹ - Sizes compatible with 56C, 143TC, 154TC, 182C and 184C face dimensions

CF Series

- Kit consists of motor face ring, mounting hardware and sensing disk (shaft mount)
- Sensing disk impervious to dust, oil and water
- Supply voltage +4.5 to +24VDC
- -40° to +125°C ambient temperature range
- NPN open collector output sinks 20mA max

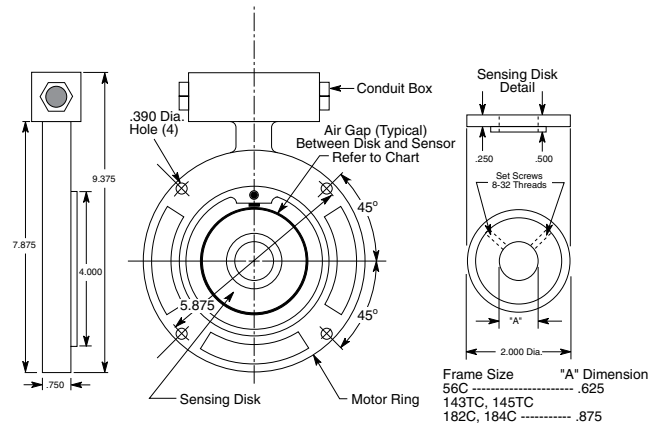

CF Series

OPU

- Senses rotation using reflective target
- 3-wire sensor produces square wave output
- NPN open collector output sinks 50mA max
- Output rise/fall: 500nS max.; 600,000 PPM max
- Supply voltage +5 to +6VDC
- 0°C to +70° ambient temperature range

^{*} See Application Note at www.dartcontrols.com

Base Model				
Indoor Model (NPN)	Outdoor Model	Pulse/Rev Output	Cable	Frame Size
PU-2E	PU-2R	1	Rubber Jacket	N/A
PU-4E	PU-4R	2	Rubber Jacket	N/A
PU-20E	PU-20R	10	Rubber Jacket	N/A
PU-40E	PU-40R	20	Rubber Jacket	N/A
CF-H1	N/A	1	N/A	56C
CF-H2	N/A	2	N/A	56C
CF-H15	N/A	15	N/A	56C
CF-H60	N/A	60	N/A	56C
CF-J2	N/A	2	N/A	143TC, 145TC, 182C, 184C
CF-J60	N/A	60	N/A	143TC, 145TC, 182C, 184C
OPU	N/A	Target Dependent	Shielded	N/A

N/A – Not available