

OPTICAL PICK-UP (OPU) SPECIFICATIONS & HOOK-UP

The OPU is a self-contained scanner capable of driving devices such as electronic counters or sensitive relays without additional amplification.

The sensor emits a steady, invisible light beam from dual infrared LEDs. Light reflected from a surface or object within its range is detected by a photo-diode. The amplified output of the photo-diode switches an NPN transistor on when light is sensed, and off when not sensed. The transistor's open collector output can be used to drive an external load of up to 50mA.

The unit is epoxy sealed inside a threaded steel housing. A six foot, 3-conductor shielded cable and two mounting nuts are furnished as standard.

The OPU can be used as a Tachometer Pick-up to sense shaft speed by placing a reflective tape or mark on the rotating shaft. It can also sense spokes on a wheel, or moving machine parts.

As a Proximity Sensor it can be used to detect objects, such as items on a conveyor. Generally, the OPU is intended for use in applications which are shielded from strong ambient light, especially sun light.

Parameter	Test Condition	Minimum	Typical	Maximum
V _{cc} Supply Voltage	---	4.5 VDC	5.0 VDC	5.5 VDC
I _{cc} Supply Current	---	---	---	35 mA
V _{cc} (sat) Collector Emitter Saturation Voltage	I _{ol} = 15 mA	---	0.3 VDC	0.5 VDC
	I _{ol} = 25 mA	---	0.5 VDC	0.8 VDC
I _{ol} Low-Level Output Current	---	---	---	50mA
t _r Output Rise Time	---	---	200 nsec	500 nsec
t _f Output Fall Timer	---	---	200 nsec	500 nsec
Operating Speed	---	---	10KHz.	---
Hysteresis	---	16%	18%	20%
Sensing Range: White surface	---	1/8 inch	---	1 inch
Reflective surface	---	3/8 inch	---	4 inches

Operating Temperature (T_a): 0° to 50° C.

Storage Temperature (T_s): -45o to +85o C.

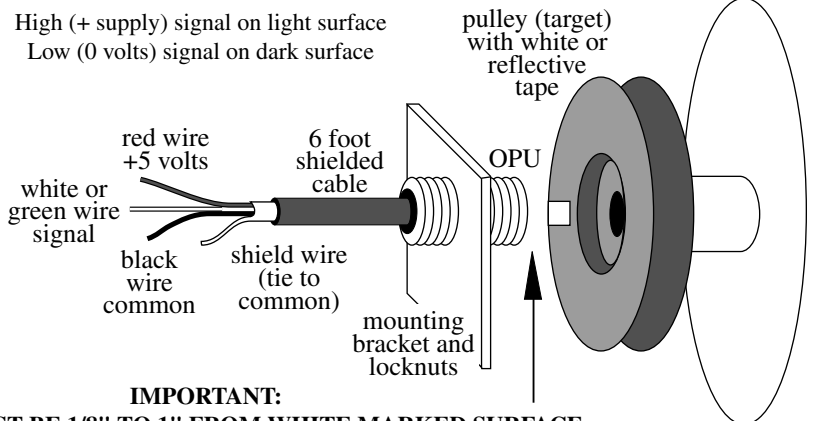
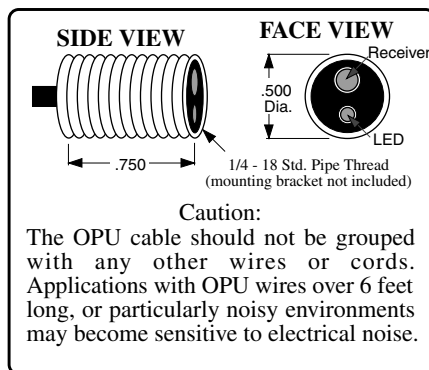

IMPORTANT:
OPU FACE MUST BE 1/8" TO 1" FROM WHITE MARKED SURFACE
OR 3/8" TO 4" FROM REFLECTIVE MARKED SURFACE !!

