

**MD10P Motor Stall;  
Drive Shutoff and Alarm Concept**  
*(this will work with all MD Series – some terminal designations may change – see User Manual)*

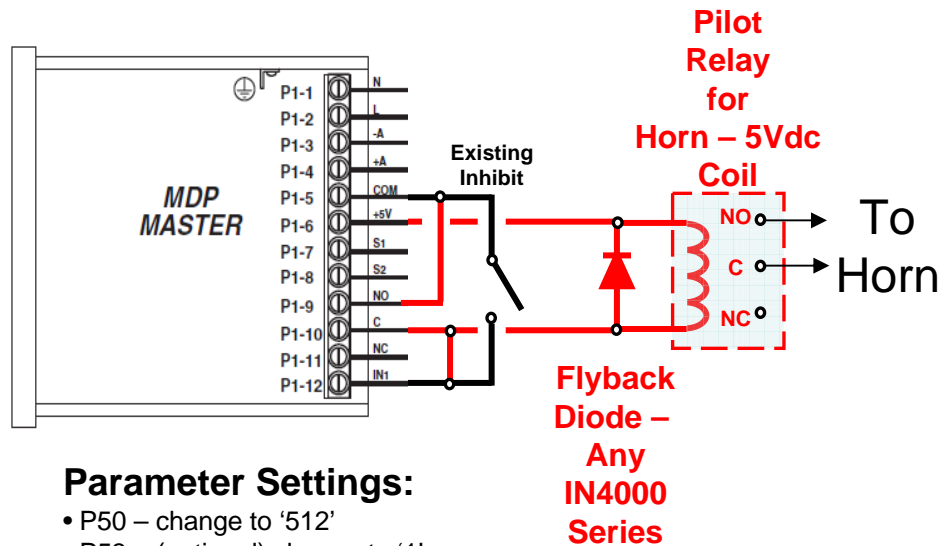

Option 1 - Audible Alarm All Inhibit Conditions



**Parameter Settings:**

- P50 – change to '512'
- P53 – (optional) change to '1'
- P57 – change to 'X', where  
is equal # seconds of stall  
until alarm activates

Option 2 - Audible Alarm Only On Motor Stall Condition

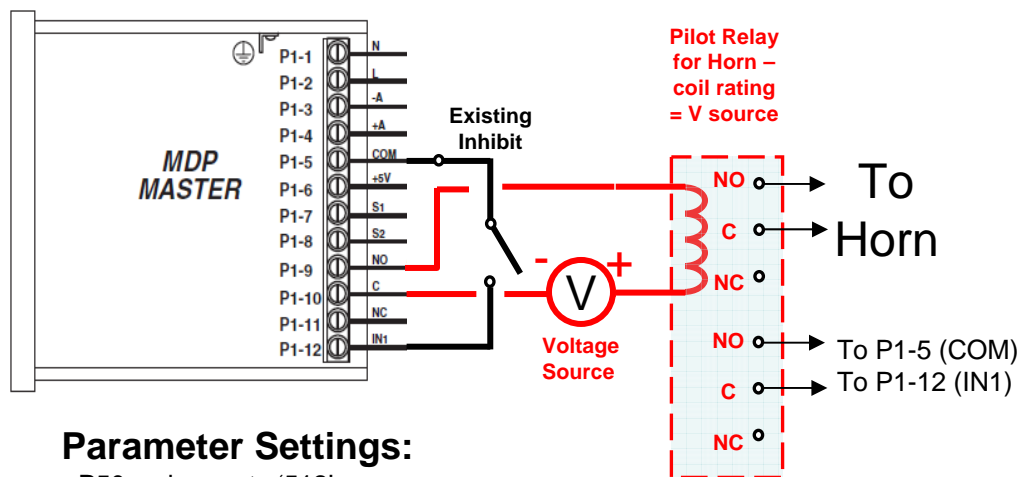

**Parameter Settings:**

- P50 – change to '512'
- P53 – (optional) change to '1'
- P57 – change to 'X', where  
is equal # seconds of stall  
until alarm activates