

125D CONTROL SERIES

DART

CONTROLS

Instruction Manual

Variable Speed Control

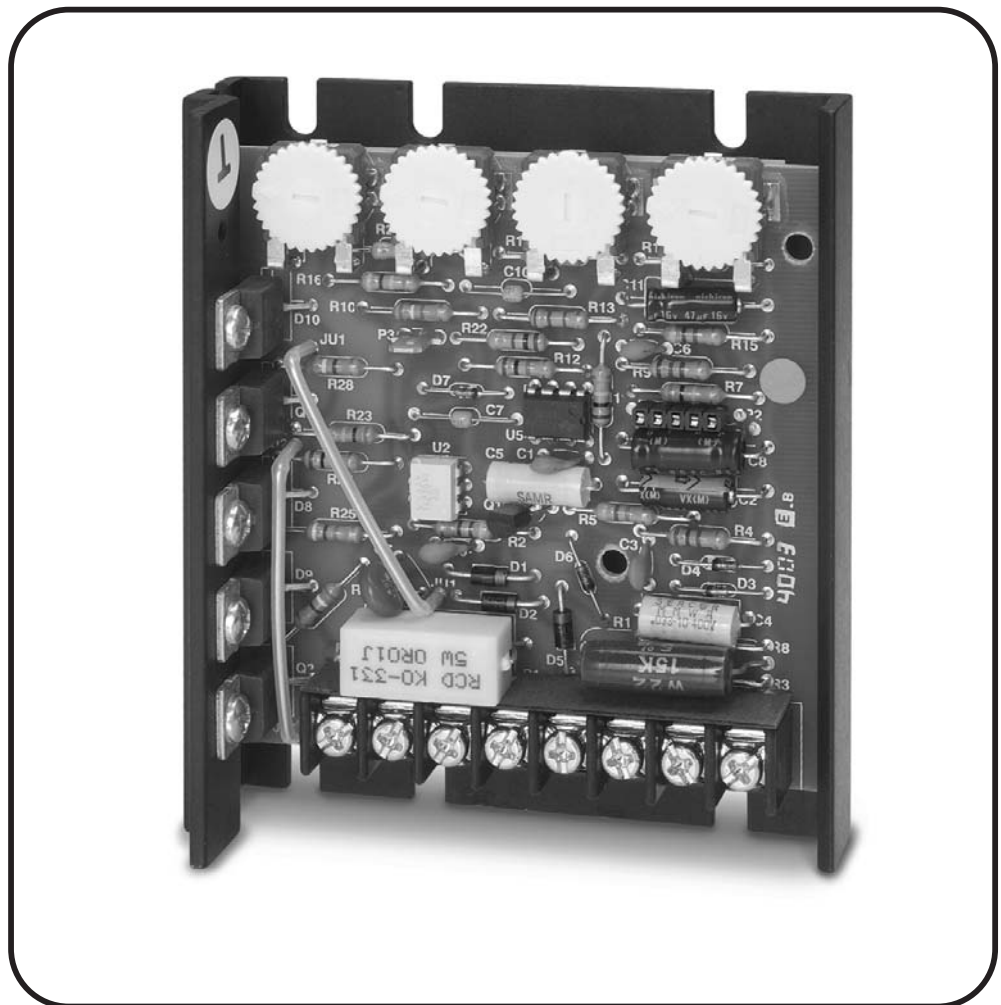

P.O. Box 10
5000 W. 106th Street
Zionsville, Indiana 46077

Phone (317) 873-5211
Fax (317) 873-1105
www.dartcontrols.com

TABLE OF CONTENTS

WARRANTY	1
INTRODUCTION	2
CONTROL FEATURES	2
125D SERIES HEATSINK DIMENSIONS	2
MOUNTING PROCEDURE	3
MODEL SELECTION	3
WIRING PROCEDURE & FUSING	3
TERMINAL STRIP WIRING INSTRUCTIONS	3
123D / 125D HOOK-UP DIAGRAM	4
CONTROL START-UP	4
TRIMPOT ADJUSTMENT CHART & PROCEDURE	5
CONTROL MODIFICATIONS	6
TWO SPEED OPERATION	6
DYNAMIC BRAKING	6
TACH FEEDBACK/FOLLOWER	6
INHIBIT FUNCTIONS	6
SPEEDPOT KIT ASSEMBLY	7
OPTION DESCRIPTION	7-10
-1 / -2A OPTIONS	7
-5 / -7 OPTIONS	8-9
-11 / -15B / -K OPTIONS / -29B OPTIONS	9
-55G / -56G OPTION	10
IN CASE OF DIFFICULTY	11
SPECIFICATIONS	11
TYPICAL MOTOR CURRENTS	12
125D SERIES PARTS PLACEMENT & LIST	12
125D SERIES SCHEMATIC	13
PRODUCT LINE	BACK COVER

WARRANTY

Dart Controls, Inc. (DCI) warrants its products to be free from defects in material and workmanship. The exclusive remedy for this warranty is DCI factory replacement of any part or parts of such product which shall within 12 months after delivery to the purchaser be returned to DCI factory with all transportation charges prepaid and which DCI determines to its satisfaction to be defective. This warranty shall not extend to defects in assembly by other than DCI or to any article which has been repaired or altered by other than DCI or to any article which DCI determines has been subjected to improper use. DCI assumes no responsibility for the design characteristics of any unit or its operation in any circuit or assembly. This warranty is in lieu of all other warranties, express or implied; all other liabilities or obligations on the part of DCI, including consequential damages, are hereby expressly excluded.

NOTE: Carefully check the control for shipping damage. Report any damage to the carrier immediately. Do not attempt to operate the drive if visible damage is evident to either the circuit or to the electronic components.

All information contained in this manual is intended to be correct, however information and data in this manual are subject to change without notice. DCI makes no warranty of any kind with regard to this information or data. Further, DCI is not responsible for any omissions or errors or consequential damage caused by the user of the product. DCI reserves the right to make manufacturing changes which may not be included in this manual.

WARNING

Improper installation or operation of this control may cause injury to personnel or control failure. The control must be installed in accordance with local, state, and national safety codes. Make certain that the power supply is disconnected before attempting to service or remove any components!!! If the power disconnect point is out of sight, lock it in disconnected position and tag to prevent unexpected application of power. Only a qualified electrician or service personnel should perform any electrical troubleshooting or maintenance. At no time should circuit continuity be checked by shorting terminals with a screwdriver or other metal device.

INTRODUCTION

- The 123D variable speed control is available in a range of 150mA through 5.5 ADC (or up to 10 ADC if using a suitable external heatsink) at 24 through 36 VAC input.
- The 125D variable speed control is available in a range of 150mA through 1/4 H.P. at 120/240 VAC input.
- The 125DV variable speed control is available in a range of 1/8 through 1 H.P. at 120/240 VAC input. With -HS(125D) or suitable external heatsink (where 125D extrusion temperature does not exceed 70° C.), maximum U.L. rating can be increased to 2 H.P. and 10 Amps DC.
- The control is designed for DC Permanent Magnet, Shunt Wound, and some Universal (AC/DC) motors in the above horsepower ranges.
- Incoming AC voltage is converted to adjustable full wave rectified DC voltage to operate the DC motor. Also, a full wave field voltage is provided for shunt wound motors (see page 11 for voltages).
- The control incorporates transient voltage protection with adjustable current limit which fits into a compact package. It features adjustable minimum and maximum speeds along with adjustable IR compensation and an inhibit function.
- Options are available to change ACCEL/DECEL time (see page 8, -15 / -K options).
- cULus Recognized under, U.L. File # E78180.

CONTROL FEATURES

MINIMUM SPEED - Allows adjustment of the motor speed when the speedpot is set at minimum (CCW). This permits the user to eliminate "Deadband" on the main speed control, permitting zero calibration. Clockwise rotation of "MIN" trimpot increases speed.

MAX SPEED (Maximum Speed) - Allows adjustment of the motor speed when the speedpot is set at maximum (CW). This permits the user to eliminate the top end "Deadband", which will provide full speed at maximum rotation. Rotation of the "MAX" trimpot in the clockwise direction increases the maximum motor speed.

I.R. COMP (Speed Regulation) - This allows for adjustment of the circuitry that controls the speed regulation of the motor. The circuitry controls armature speed by changing the armature voltage to compensate for increased or decreased motor loading. Clockwise rotation of the "IR COMP" trimpot will increase compensation.

CUR. LIM. (Current Limit) - Provides protection from excessive armature current by limiting the maximum armature current the control can provide. This enables adjustment of the maximum torque the motor can deliver. Torque adjustment (Cur. Lim.) is preset at 125% of rated motor torque (current) based on horsepower. Clockwise rotation of the "CUR. LIM." trimpot increases the torque (current) the control will provide.

INHIBIT TERMINAL PIN - Allows the user a choice of stopping and starting hard (fast) or stopping hard with a soft start through an adjustable acceleration ramp, without breaking the AC lines (see page 6).

TERMINAL STRIP - Allows for connection of AC lines, motor leads, motor field (if needed), and speed potentiometer

125D SERIES HEATSINK DIMENSIONS

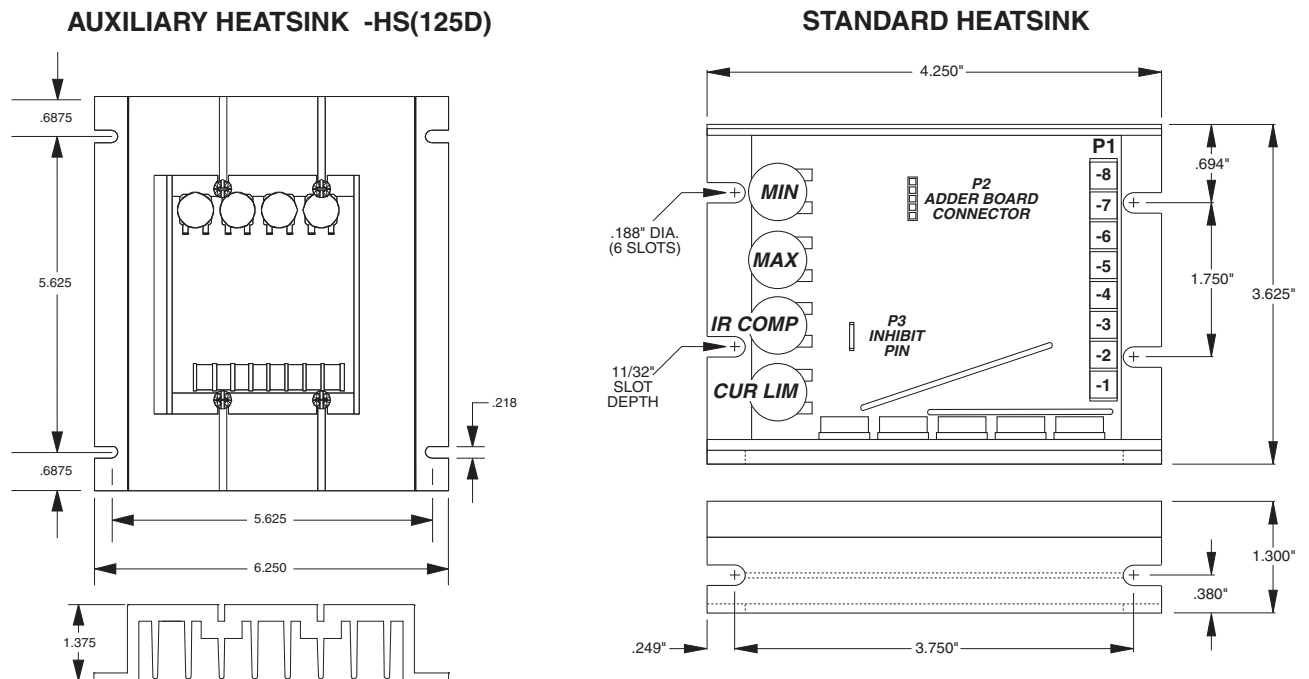

MOUNTING PROCEDURE

1. Six 3/16" wide slots are provided for control mounting.
2. Control chassis can be used as a template.
3. Use standard hardware to mount.

CAUTION:

DO NOT MOUNT WHERE AMBIENT TEMPERATURE IS OUTSIDE THE RANGE OF -10° C (15° F) TO 45° C (115° F)

MODEL SELECTION

HORSEPOWER	INPUT VOLTAGE	OUTPUT VOLTAGE	OUTPUT* AMPS DC	MODEL NUMBER
150mA thru 5.5 A	24 to 36 VAC	0-20 / 0-30 VDC	5.5A	123D-C*
1/50 thru 1/8	120/240 VAC	0-90 / 0-180 VDC	1.2A	125D-12C
1/8 thru 1	120/240 VAC	0-90 / 0-180 VDC	5.5A	125DV-C*

NOTE: * With -HS(125D) or suitable external heatsink (where 125D extrusion temperature does not exceed 70° C.), maximum U.L. for Output Amps can be increased to 10 Amps D.C.

WIRING PROCEDURE & FUSING

1. Size all wires which carry armature or line currents **AS SPECIFIED BY NATIONAL, STATE, AND/OR LOCAL CODES**. All other wires may be # 18 AWG or smaller as permitted by local code.
2. **Separate control wires** from the armature and AC lines when routed in conduit or in wire trays.
3. **Fusing** - The motor and control are protected against overloads by the current limit circuit and a customer installed fuse in the AC line. **THIS PROTECTION ALREADY MAY BE PROVIDED BY THE CUSTOMER WITH CIRCUIT BREAKERS OR FUSES IN BOTH MAIN LINES. IF NOT:**

FOR 120 VAC INPUT - fuse protection should be added by the customer in AC Line 1 (see following chart)

FOR 240 VAC INPUT - fuse protection should be added by the customer in AC Line 1 and Line 2 (see following chart)

FUSING ADDED BY CUSTOMER (Bussman ABC or Little Fuse 314 Series ceramic fuses)

HORSEPOWER	120 VAC INPUT	240 VAC INPUT
1/50	2 AMP	-----
1/20	2 AMP	1 AMP
1/8	3 AMP	2 AMP
1/4	4 AMP	3 AMP
1/3	6 AMP	3 AMP
1/2	8 AMP	4 AMP
3/4	12 AMP	6 AMP
1.0	15 AMP	8 AMP
1.5	-----	12 AMP
2.0	-----	15 AMP

NOTE: To determine fusing for the 123D-C Series control (24 to 36 VAC input), use 200% of Full Load Current.

TERMINAL STRIP WIRING INSTRUCTIONS

The 125D Series uses an 8 position terminal strip for ease of connection.

- P1-1,2** (AC or L) 120 VAC - Connect incoming hot AC or L (black wire) to P1-1 and neutral AC or N (white wire) to P1-2. Connect ground (green wire) to CHASSIS of control.
 (AC or N) 240 VAC - Connect both hot sides (L & N), one to P1-1 and one to P1-2. Connect ground wire to CHASSIS of control.
- P1-3** (+Arm) Connect to PLUS (+) Armature wire on motor. 0-90 VDC for 120 VAC input or 0-180 VDC for 240 VAC input. See "SPECIFICATIONS" for output rating.
- P1-4** (-Arm/-Field) Connects to MINUS (-) Armature wire on motor and, if necessary, connect MINUS (-) Field wire of SHUNT WOUND MOTOR.

(continued)

P1-5

(+Field) **DO NOT** use for Permanent Magnet Motor. This supplies +Field voltage for a SHUNT WOUND MOTOR (refer to field voltage table). For motors with dual voltage field (ie. 50/100V or 100/200V), make sure highest value is connected.

FIELD VOLTAGE TABLE				
VAC INPUT	24	36	120	240
VDC FIELD	20	30	100	200

P1-6

(Speedpot Hi) Connects to high side (white wire) of Speedpot (CW end). This is internal +12 volts. For start-stop applications, the connection between this terminal and Speedpot HI can be opened and closed by a SPST switch. **INPUT MUST NOT BE GROUNDED!**

P1-7

(Speedpot Wiper) Connects to wiper (red wire) of Speedpot (center lead). For Voltage Follower applications, this **INPUT MUST NOT BE GREATER THAN +12V MAXIMUM AND MUST NOT BE GROUNDED!**

P1-8

(Speedpot Lo) Connects to Low side (orange wire) of 5K Speedpot (CCW end). This input is raised and lowered by the MIN. trimpot (5K). Electronic speed input (voltage follower) may be referenced to Speedpot LO if the MIN trimpot adjustments are to be active. Otherwise, inputs may be referenced to -ARM, which will bypass the MIN trimpot. **INPUT MUST NOT BE GROUNDED!**

Warning:

1. Be sure the control housing is properly grounded.
2. Armature connections must not be switched or broken while the control is on. Serious control damage may result.
3. For non-speedpot applications, the input connection to the LO, WIPER, and HI terminals must not be grounded! Serious control damage may result from a grounded input.

123D/125D HOOK-UP DIAGRAM

Warning:

Do not attempt to perform Hi-pot test across AC lines with control in circuit. This will result in immediate or long term damage to the control.

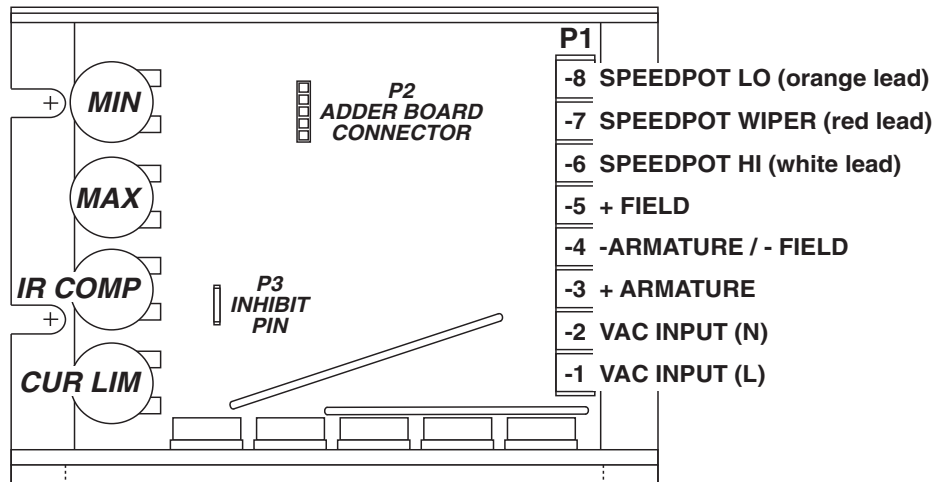

CONTROL START-UP

WARNING: ALL POWER MUST BE TURNED OFF BEFORE PROCEEDING!

1. Recheck all wiring. Accidental grounds, loose or pinched wires on armature or speedpot wires may damage the control when power is applied.
2. Check to see that incoming service is of correct voltage.
3. Turn speedpot to zero (fully CCW).
4. Turn power on, and advance speedpot while observing motor. **Power must be off before step 5 can be accomplished!**
5. If motor rotation is incorrect, turn power off at external disconnect and reverse +ARM and -ARM connections.
6. Check for satisfactory operation throughout the speed range.
7. If operation is satisfactory, no readjustments are needed.
8. If instability or surging is observed, or if maximum speed is higher than desired, see "TRIMPOT ADJUSTMENT CHART " on page 5.
9. For other problems, consult page 10, "IN CASE OF DIFFICULTY".

TRIMPOT ADJUSTMENT CHART & PROCEDURE

Settings apply when using a 5K ohm master speedpot. This chart is used in conjunction with the adjustment procedure and is approximate.

	C.L.	I.R.	MAX	MIN	HP
125D-12C 120 VAC input; 0-90 VDC output					1/50
					1/20
					1/8
125DV-C 120 VAC input; 0-90 VDC output					1/8
					1/4
					1/3
					1/2
					3/4*
					1.0*

Operation of the control beyond $\pm 10\%$ of the normal line voltage could result in re-adjustment. These adjustments are permanent; periodic re-adjustment is normally not needed.

Settings apply when using a 5K ohm master speedpot. This chart is used in conjunction with the adjustment procedure and is approximate.

HP	C.L.	I.R.	MAX	MIN	
1/20					125D-12C 240 VAC input; 0-180 VDC output
1/8					
1/4					
1/4					125DV-C 240 VAC input; 0-180 VDC output
1/3					
1/2					
3/4*					
1.0*					
1.5*					
2.0*					

* NOTE: ADDITIONAL CUSTOMER HEATSINK REQUIRED FOR 125DV-C (120 VAC INPUT - GREATER THAN 1/2 H.P. MOTORS) AND (240 VAC INPUT - GREATER THAN 1 H.P. MOTORS). 125 EXTRUSION TEMPERATURES SHOULD NOT EXCEED 70 DEGREES C.

NOTE: FOR DETERMINING TRIMPOT SETTINGS FOR THE 123D-C SERIES, SEE TRIMPOT SETTINGS PROCEDURE BELOW.

TRIMPOT	FUNCTION	ADJUSTMENT
MIN.	Sets minimum motor speed when speedpot is set at zero. CW rotation will increase minimum motor speed.	<ol style="list-style-type: none"> 1. Set Speedpot to zero (fully CCW). 2. Rotate MIN trimpot CW until motor starts to rotate. 3. Slowly rotate MIN trimpot CCW until motor stops. NOTE: If motor rotation is desired, rotate MIN trimpot CW until desired MIN speed is reached.
IR COMP	Provides a means of improving motor speed regulation in the armature feedback mode. If a slowdown due to load change is of no concern, rotate this trimpot fully CCW.	<ol style="list-style-type: none"> 1. Set Speedpot at 50%. 2. Observe motor speed at no load condition. 3. Apply full load to motor. 4. Turn IR COMP trimpot CW to obtain the same motor speed as with no load.
MAX.	Sets maximum motor speed when speedpot is set at maximum (fully CW rotation). CW rotation of MAX trimpot increases maximum motor speed.	<ol style="list-style-type: none"> 1. TURN DRIVE POWER OFF!! 2. Connect a DC Voltmeter: + to +ARM, - to -ARM. NOTE: Meter must not be grounded!! 3. Set meter voltage range: (90 VDC for 120 VAC, 180 VDC for 240 VAC). 4. Turn power on. Set Speedpot at 100%. 5. Adjust MAX trimpot to rated motor armature voltage as shown on meter. NOTE: A tachometer or strobe may be used in lieu of a meter. Follow above steps, except adjust MAX trimpot to rated motor base speed indicated by tachometer or strobe.
CUR.LIM.	Limits DC motor armature current (torque) to prevent damage to the motor or control. The current limit is set for the rated motor current. CW rotation of this trimpot increases the armature current (or torque produced).	<ol style="list-style-type: none"> 1. TURN DRIVE POWER OFF!! 2. Connect a DC Ammeter between A1 on motor and +ARM on control. This is in series with the motor. 3. Turn power on. 4. Set Speedpot at the 50% position. 5. Apply friction braking to motor shaft until motor stalls. 6. With motor stalled, set current at 125% of rated motor armature current by adjusting CUR. LIM. trimpot.

CONTROL MODIFICATIONS

TWO SPEED OPERATION

Two pot operation is done using two 10K ohm speed potentiometers in parallel (both HI's to P1-6, both LO's to P1-8). The WIPER is switched using a SPDT switch.

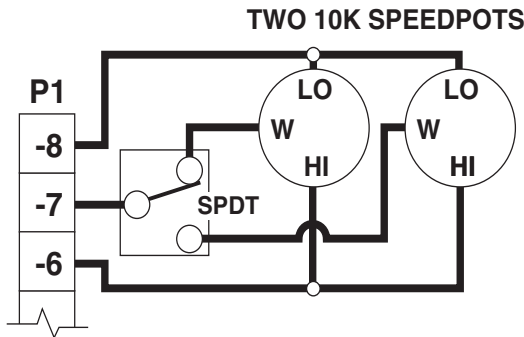

DYNAMIC BRAKING

A DPDT switch is used to inhibit the control and to connect the DBR. Typical values for the DBR (dynamic brake resistor) are 5 ohms for 120V, 10 ohms for 240V (both 35W to 50W). Note that motor horsepower, inertia, and cycle time effect sizing of the DBR. NOTE: This modification cannot be used with any of the -15 options.

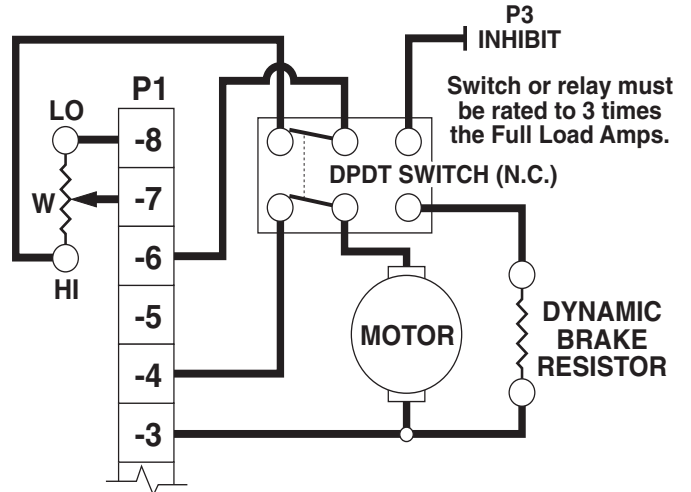

TACHOMETER FEEDBACK

Improves speed regulation to $\pm 1/2\%$ of base speed.

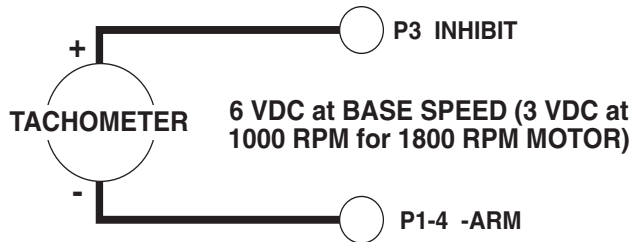

TACHOMETER FOLLOWER

Allows control output to follow tachometer voltage.

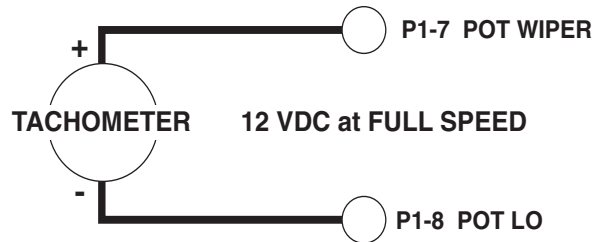

NOTE: NEED 1% OR LESS - TACH OUTPUT RIPPLE

INHIBIT (USED INDEPENDENTLY)

The customer supplied SPST switch is connected in series between the speedpot HI (P1-6) and the Inhibit pin (P3). To inhibit (stop motor), speedpot HI is closed to the Inhibit pin. To restart, the switch is returned to open. NOTE: The control will stop and start fast.

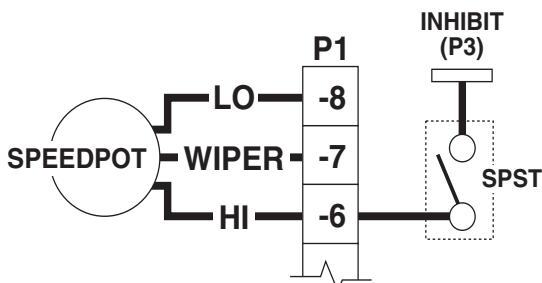

INHIBIT (USED WITH SPEEDPOT)

The Common of the SPDT switch is connected to control pot HI and is switched between Speedpot HI and the Inhibit pin (P3). To inhibit (stop motor), speedpot HI is closed to the Inhibit pin. To restart, the switch is returned to Speedpot Hi. NOTE: The control will stop fast and soft start through a fixed acceleration range.

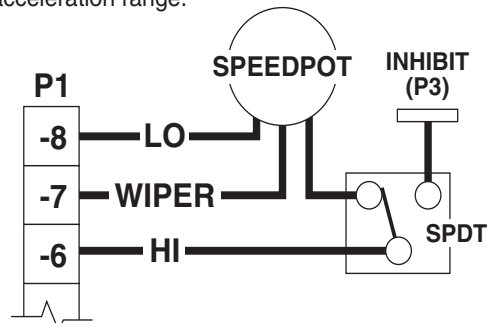

NOTE: Permits starting and stopping of motor without breaking AC lines. In the event of SCR failure or false triggering, the Inhibit circuit will not stop motor.

Always use a shielded wire when connecting to the inhibit terminal. The shield should be connected to -Armature or Common of the control.

SPEEDPOT KIT ASSEMBLY

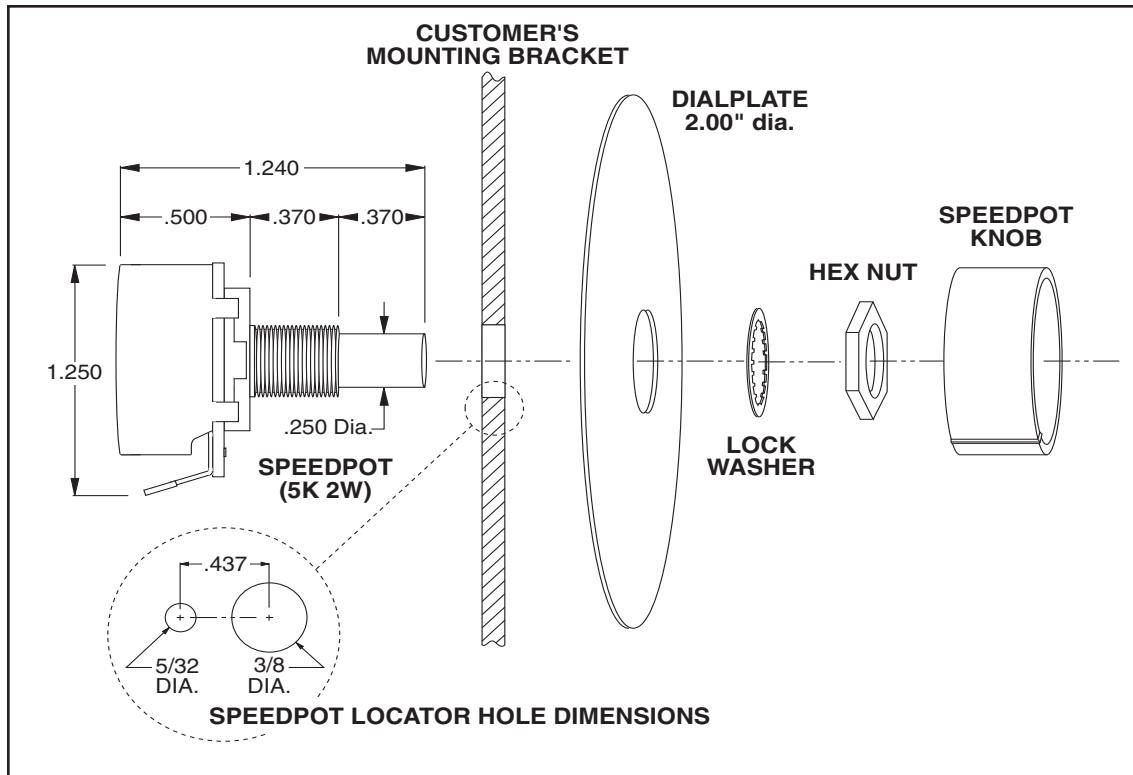

OPTION DESCRIPTIONS

-1 option **Electronic Speedpot Interlock**

Field or Factory Installed
Available All Models

The -1 adder board connects to the 125 series board through use of a female connector and plastic standoff support.

When incoming AC power to the control is applied, the Electronic Interlock will prevent the motor from starting until the speedpot is first rotated to the zero position and then rotated clockwise toward the set speed.

Also, should the incoming AC power be interrupted for any reason, then restored, the Electronic Interlock will prevent an automatic restart of the motor. To restart, the speedpot must first be rotated to the zero position and then rotated clockwise toward the set speed.

CAUTION: The Electronic Interlock becomes inoperative if SCR failure should occur.

-2A option **Individually Adjustable Linear Accel and Decel**

Field or Factory Installed
Available All Models

This option plugs into the five position expansion connector on the 125D main board. The -2A option overrides the fixed accel ramp built into the 125D control, providing independently adjustable linear accel and decel from 0.5 to 8.0 seconds. To install, flip over the -2A option board so the printed circuit lines are visible. Align the male connector CN1 (-2A option) with the female connector P2 (125D board) so terminal CN1-1 fits into P2-6, CN1-2 in P2-5, etc. Align the plastic stand-off on the -2A option board with the hole shown on the 125D main board. Once connectors and stand-off are aligned, snap into place. Adjustment of both trimpots is accomplished via the labeled access holes on the back side of the -2A option board. Full CCW rotation equals minimum accel or decel time and full CW rotation equals maximum accel or decel time. Note: Each trimpot operates independently of the other.

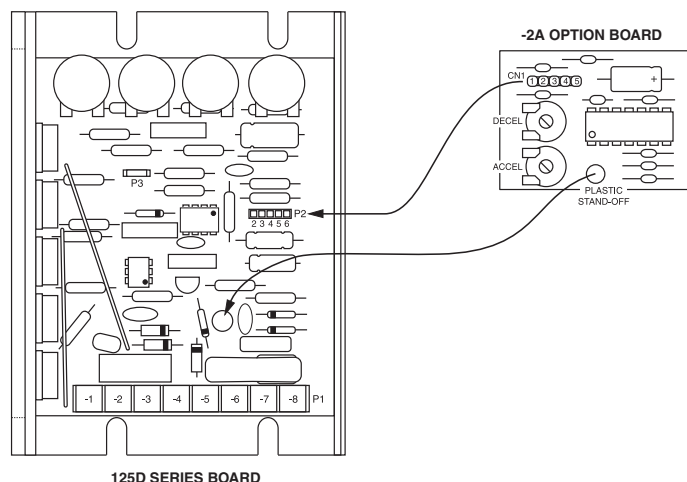

-5 option **Isolated 4-20 ma.Signal Follower**

Field or Factory Installed
Available All Models

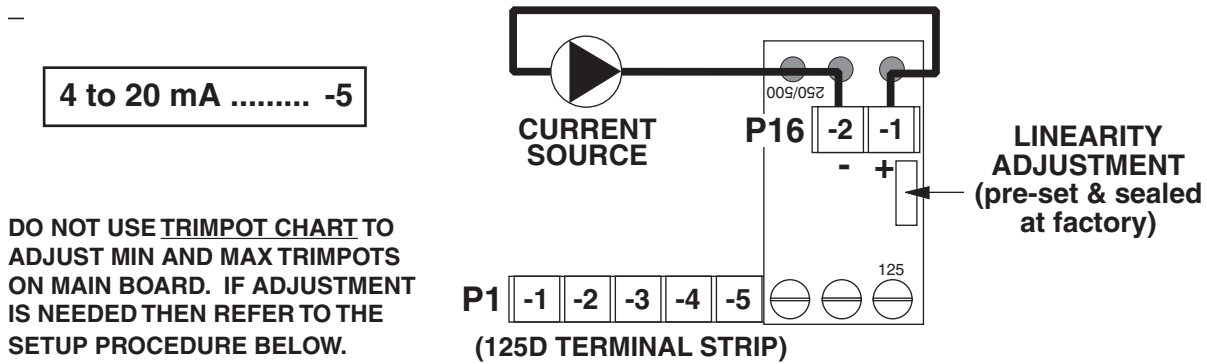

DO NOT USE TRIMPOT CHART TO ADJUST MIN AND MAX TRIMPOTS ON MAIN BOARD. IF ADJUSTMENT IS NEEDED THEN REFER TO THE SETUP PROCEDURE BELOW.

This option replaces the speedpot with a 4-20 ma. signal to control speed. The current signal input can be either grounded or ungrounded. The board sets on spacers screwed to terminals P1-6, P1-7, and P1-8 on the main board using long screws. The current source connects to the + and - two position terminal strip (P16-1 and -2) on the -5 option board.

The Linearity trimpot on the -5 option board is set at the factory for proper linearity, however this trimpot may need to be re-set after tuning the controls Max and Min trimpot settings for your specific application. If needed then refer to the setup procedure below.

Setting the Min, Max and Linearity Trimpots.

1. Preset the multi-turn Linearity trimpot on the -5 option board full CW, set the Min trimpot full CCW and set the Max trimpot at about 50% rotation.
2. Input a 4 ma. current signal to the control and turn the Min trimpot CW to your desired minimum output voltage or to deadband (the point just before you begin to get an output).
3. Input a 20 ma. current signal to the control and set the Max trimpot to the desired maximum speed setting.
4. With 20 ma. still going to the control, turn the Linearity trimpot CCW until your output speed starts to decrease. Then slowly turn it back CW until you just reach your maximum speed setting.

-7 option **Isolated 4-20 ma. Signal Follower with Auto / Manual Switch**

Field or Factory Installed
Customer Wired

DO NOT USE TRIMPOT CHART TO ADJUST MIN AND MAX TRIMPOTS ON MAIN BOARD. IF ADJUSTMENT IS NEEDED THEN REFER TO THE SETUP PROCEDURE BELOW.

This option allows the control to be run in either the Manual mode via a speed pot or the Auto mode via the 4-20 ma. signal. The current signal input can be either grounded or ungrounded. The board sets on spacers screwed to terminals P1-6, P1-7, and P1-8 on the main board using long screws. The current source connects to the + and - two position terminal strip (P16-1 and -2) on the -7 option board.

This option includes a Balance trimpot which is used to scale the maximum speed in the manual mode. It is factory set so the maximum speed in manual equals the maximum speed in automatic.

The Linearity trimpot on the -7 option board is set at the factory for proper linearity, however this trimpot may need to be re-set after tuning the Max and Min trimpot settings on the control or if the Balance trimpot on the -7 must be reset for your specific application. If needed then refer to the setup procedure below.

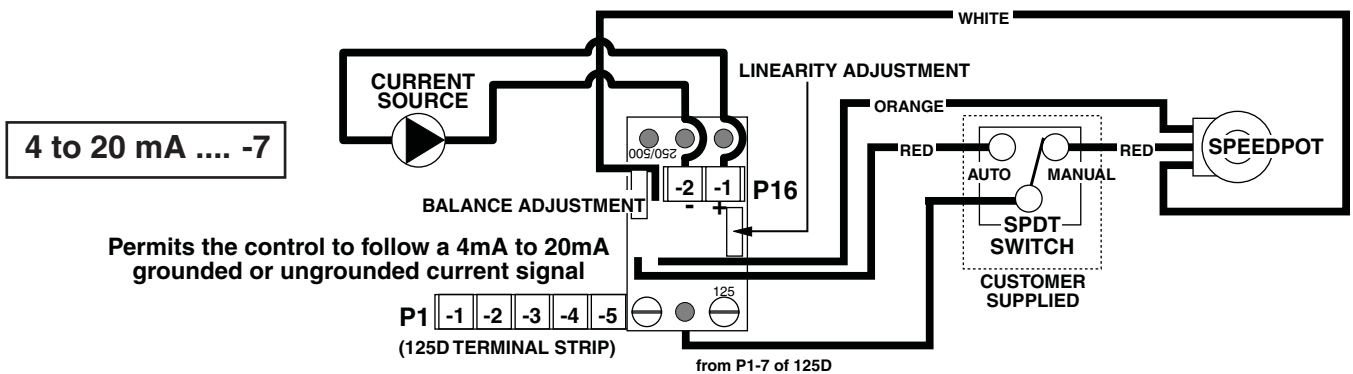

Setting the Min, Max, Balance and Linearity Trimpots.

1. Preset the multi-turn Linearity trimpot and the Balance trimpot on the -7 option board full CW, set the Min trimpot full CCW and set the Max trimpot at about 50% rotation.
2. Input a 4 ma. current signal to the control and turn the Min trimpot CW to your desired minimum output voltage or to deadband (the point just before you begin to get an output).
3. Input a 20 ma. current signal to the control and set the Max trimpot to the desired maximum speed setting.
4. Switch the control to the Manual mode setting and adjust the Balance trimpot CCW as needed to attain your required manual mode maximum output speed. (Adjustable from 50 to 100% of maximum Auto mode setting)
5. Switch the control back to Auto mode. With 20 ma. still going to the control, turn the Linearity trimpot CCW until your output speed starts to decrease. Then slowly turn it back CW until you just reach your maximum speed setting.

-11 option

10 Turn Master SpeedPot

**Field Installed
Available All Models**

Provides finer control of speed. Use standard Hook-up directions and Trimpot Chart (page 5).

-15B / -K options

Acceleration Time Ranges

Factory Installed

This option provides the Accel times shown below. The standard Accel time is 0.5 seconds.

	-15B OPTION	-K OPTION
ACCELERATION TIME	4 seconds	6 seconds
USE STANDARD HOOK-UP		

-29B option

Manual Forward-Off-Reverse Switch

Field Installed Only

Permits reversing of motor. This is accomplished using a 4PDT blocked center switch. When switched between the forward/reverse positions, a delay is encountered due to the blocked center position, which protects the control from any voltage that may be at the ARM terminals. The center position is OFF/NEUTRAL.

THE MOTOR MUST COME TO A COMPLETE STOP BEFORE CHANGING DIRECTIONS. IF THE MOTOR DOES NOT COME TO A COMPLETE STOP, SERIOUS DAMAGE TO THE CONTROL MAY RESULT. BYPASS OF THE SWITCH CENTER BLOCK MAY RESULT IN DAMAGE TO THE CONTROL.

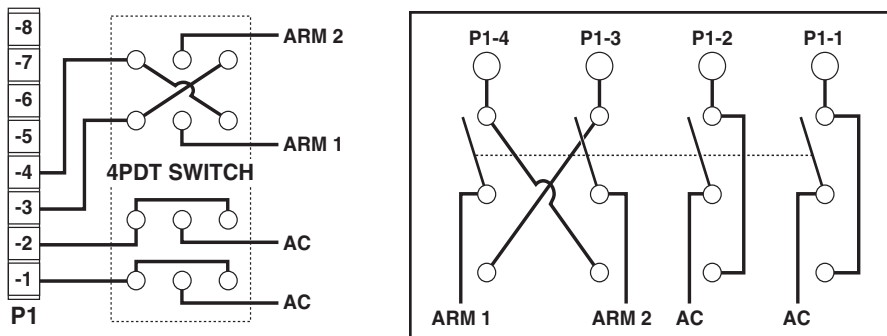

-55G option

Isolated Voltage Input

Factory or Field Installed

NOTE: This option cannot be used on the 123D-C series control.

This option permits either a grounded or non-grounded remote DC voltage speed command. This DC input can range from 0-5VDC through 0-25VDC or 0-25VDC through 0-250VDC (which can be selected via the range jumper clip and adjusted with the GAIN trimpot). The output of this option board supplies a linear pulse width modulated signal to the control that is proportional to the input signal supplied to the option board. The option replaces the 5K speedpot. Input impedance is 1.2M ohms on high scale, and 150K ohms on low scale.

NOTE: Range jumper connector is used to select input voltage range. When installed from P4-1 to P4-2, the range is 0-25VDC through 0-250VDC; when installed from P4-2 to P4-3, range is 0-5VDC through 0-25VDC.

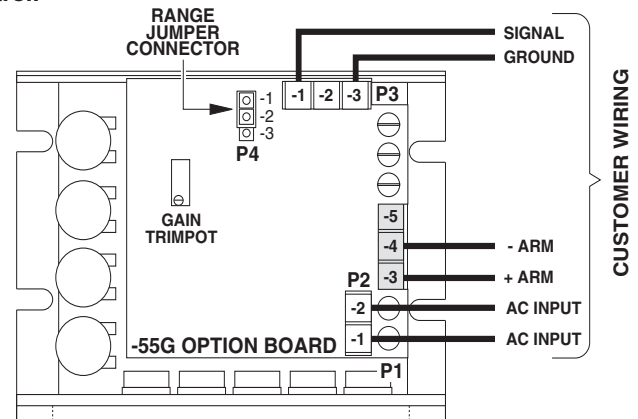

(FOR SHUNT WOUND MOTOR, SEE PAGE 4 OF MANUAL FOR FIELD CONNECTIONS).

CAUTION: DO NOT use TRIMPOT ADJUSTMENT CHART. Set pots using directions in following SET-UP PROCEDURES.

SETUP PROCEDURE FOR -55G AND -56G OPTIONS

1. With **NO** power to control, connect a DC Voltmeter (meter must not be grounded) to control outputs as follows: Meter COMMON to the -ARM terminal, Meter POSITIVE to the +ARM terminal. Select correct meter range (0-90V or 0-180V).
2. Preset GAIN trimpot on option board fully CCW, place range jumper clip in proper position.
3. Preset control as follows: MIN, MAX & IR fully CCW, and Current Limit fully CW.
4. Apply AC power of correct voltage to control and option board.
5. With 0 volts into option board, adjust MIN trimpot of control to eliminate deadband. To do this, increase MIN fully CW, then adjust CCW until meter reads 0 volts.
6. Apply maximum input voltage to option board input. Motor will start to rotate.
7. Adjust GAIN until no further change in control output voltage occurs, back off approximately 1 turn, then set control MAX. setting to 90 VDC (180VDC for 240V units).
8. Current Limit is set as shown on "TRIMPOT ADJUSTMENT CHART" on page 5.
9. For Closed Looped systems the IR should remain fully CCW. For Open Looped systems, set IR as needed

-56G option

Isolated Voltage Input with Auto / Manual Switch

Factory or Field Installed

NOTE: This option cannot be used on the 123D-C series control.

This option permits either a grounded or non-grounded remote DC voltage speed command. This DC input can range from 0-5VDC through 0-25VDC or 0-25VDC through 0-250VDC (which can be selected via the range jumper clip and adjusted with the GAIN trimpot). The output of this option board supplies a linear pulse width modulated signal to the control that is proportional to the input signal supplied to the option board. The option replaces the 5K speedpot. Input impedance is 1.2M ohms on high scale, and 150K ohms on low scale.

(FOR SHUNT WOUND MOTOR, SEE PAGE 4 OF MANUAL FOR FIELD CONNECTIONS).

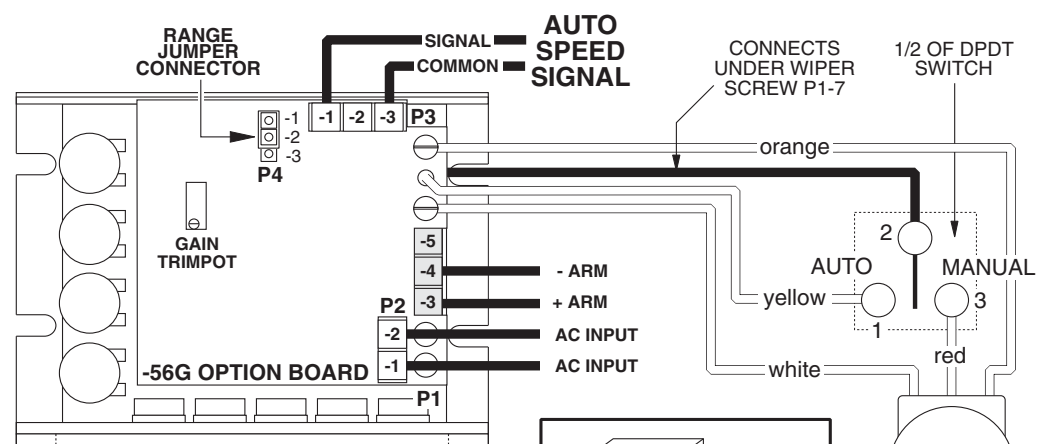

NOTE: Range jumper connector is used to select input voltage range. When installed from P4-1 to P4-2, the range is 0-25VDC through 0-250VDC; when installed from P4-2 to P4-3, range is 0-5VDC through 0-25VDC.

— = CUSTOMER WIRING
 = FACTORY WIRING

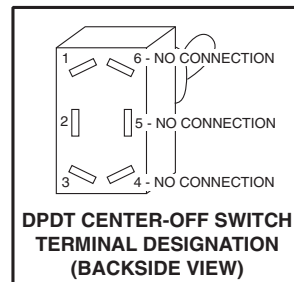

CAUTION: DO NOT use TRIMPOT ADJUSTMENT CHART. Set pots using directions in following SET-UP PROCEDURES.

IN CASE OF DIFFICULTY

PROBLEM	POSSIBLE CAUSE(S)	CORRECTIVE ACTION(S)
Motor doesn't operate	<ul style="list-style-type: none"> - Blown Fuse or Breaker - Incorrect or no power source - Speedpot set at Zero - Worn motor brushes 	Replace Fuse or reset breaker Install proper service Adjust Speedpot CW to start Replace brushes
Armature output voltage cannot be adjusted, output is a constant DC level Motor stalls, or runs very slowly with speed control turned fully CW	<ul style="list-style-type: none"> - No motor or load connected - Speedpot low connection open - Low Voltage - Overload Condition - Worn motor brushes - MAX SPEED set incorrectly 	Check that motor or load is connected to armature terminals Check that speedpot low wire is connected Check that VAC is above 100VAC Reduce load or increase motor size and/or C.L. setting. Replace brushes See ADJUSTMENT PROCEDURE
Motor hunts	<ul style="list-style-type: none"> - Motor current less than 150Ma - Too much IR COMP - Motor is in current limit - Motor speed is above rated speed - Max set too high 	Motor current must be greater than 150mA D.C. See ADJUSTMENT PROCEDURE See ADJUSTMENT PROCEDURE Reduce Speed See ADJUSTMENT PROCEDURE
Repeated fuse blowing	<ul style="list-style-type: none"> - Low Voltage 	

If control still will not operate, go to www.dartcontrols.com/support or call (317) 873-5211.

SPECIFICATIONS

AC input voltage	±10% of rated line voltage
Acceleration	0.5 seconds (standard 125D)
Amps - DC output	150 mA to 5.5 ADC*
Controller overload capacity	200% for one minute
Current limit trimpot range	0.3 to 2.5 ADC (125D); 1 to 15 ADC (123D & 125DV)
Deceleration	0.5 seconds (standard 125D)
Dimensions and weights:	

	WIDTH	LENGTH	DEPTH	WEIGHT
ENGLISH	3.625"	4.250"	1.300"	8.00 oz.
METRIC	92mm	108mm	33mm	228 gms.

Drive service factor	1.0
Efficiency	85% typical
Input frequency	50 or 60 Hertz
Max. trimpot speed range	60% to 110% of base speed
Min. trimpot speed range	0% to 30% of maximum speed
Power devices	isolated case tab
Shunt field voltage	20VDC for 24VAC input; 30VDC for 36VAC input; 100VDC for 120VAC input; 200VDC for 240VAC input; 1 amp maximum
Speed control	via 5Kohms 2W potentiometer or 0-10VDC isolated signal
Speed range	50:1
Speed regulation	±1% of base speed
Temperature range	-10° to 45° C. ambient (15° to 115° F.)
Transient protection	G-Mov**
Trigger	opto-coupler
Type ramp of accel/decel	RC time constant

* With -HS(125D) or suitable external heatsink (where 125D extrusion temperature does not exceed 70° C.), maximum U.L. rating for output amps can be increased to 10 amps D.C.

** not used on the 123D-C series control

TYPICAL MOTOR CURRENTS

Horsepower	1/50	1/20	1/8	1/4	1/3	1/2	3/4	1.0	1.5	2.0
Typical AC Amps (120VAC)	0.50	1.00	2.00	3.50	4.40	6.50	9.30	13.20	-----	-----
Typical Arm Amps (120VAC)	0.42	0.81	1.60	2.70	3.40	5.00	8.20	10.90	-----	-----
Typical AC Amps (240VAC)	-----	0.80	1.20	1.80	2.20	3.30	4.80	6.50	9.70	12.90
Typical Arm Amps (240VAC)	-----	0.40	0.60	1.40	1.70	2.50	3.70	5.00	8.20	11.60

125D SERIES PARTS PLACEMENT & LIST

RESISTORS

R1	15K 6W
R2	470 Ω
R3	2.7K
R4	2.7K
R5	82K
R6	5K (MIN TRIM)
R7	300K
R8	180K
R9	1.2M
R10	39K
R11	100K
R12	10K
R13	2.2K
R14	820 Ω
R15	4.7K
R16	470K
R17	1K
R18	100 Ω (I.R. TRIM)
R19	5K (C.L. TRIM)
R20	300K
R21	10K (MAX TRIM)
R22	1K
R23	300K
R24	.01 Ω 5W
R25	91K
R26	1K
R27	390 Ω
R28	390 Ω
R29	5K SPEEDPOT *

ACCEL CHANGES

Replace N.P. cap with polarized cap (see above)

- 15A ... C8 ... 33uf 16V
- 15B ... C8 ... 15uf 25V
- 15C ... C8 ... 4.7uf 16V
- K C8 ... 22uf 16V

125D-12C (1/50 thru 1/8 H.P.) CHANGES:

R24062 Ω 5W

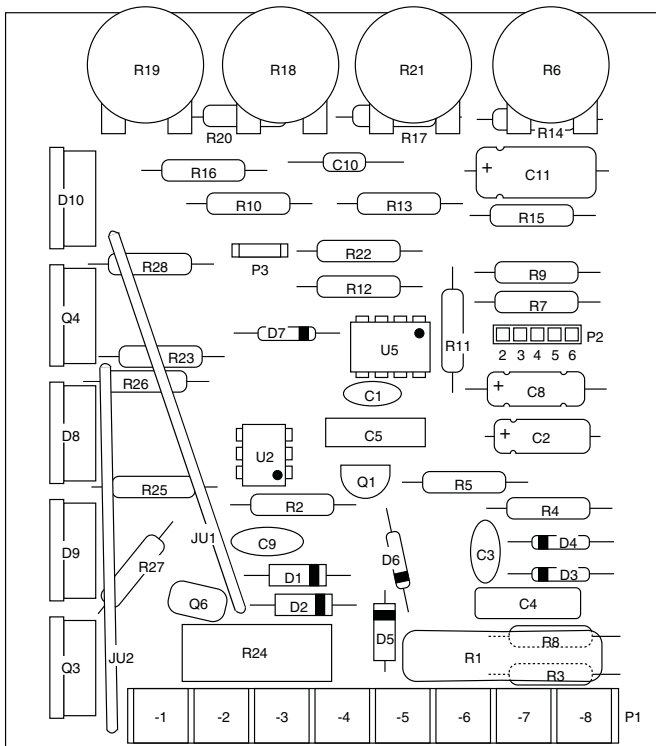

ACTIVE DEVICES

Q1	2N6027
U2	3052 MOC
Q3	S4015L
Q4	S4015L
U5	LM358 IC
Q6	275V G-MOV

CAPACITORS

C1	.01μF 100V
C2	10μF 35V
C3	.01μF 100V
C4	.033μF 400V
C5	.22μF 1KV
C8	1μF 50V N.P.
C9	.0047μF 1KV
C10	.1μF 50V
C11	47μF 16V

DIODES

D1	1N4005
D2	1N4005
D3	1N914B
D4	1N5242B
D5	1N4005
D6	1N5233B
D7	1N914B
D8	D4015L
D9	D4015L
D10	D4015L

123D-C CHANGES:

D6	1N914B (reverse direction)
Q6	DELETE
R1	1K 2W
R2	47Ω
R16	220K
R23	47K
R25	15K
R27	47Ω
R28	47Ω

MISCELLANEOUS

JU1	18GA. SOLID INSULATED WIRE
JU2	18GA. SOLID INSULATED WIRE
PCB	A-4-2033F PRINTED CIRCUIT
P1 (-1 THRU -8)	8 POS. TERMINAL STRIP
P2 (-2 THRU -6)	5 POS. FEMALE CONNECTOR
P3	3/16" MALE SPADE PIN

125D SERIES SCHEMATIC

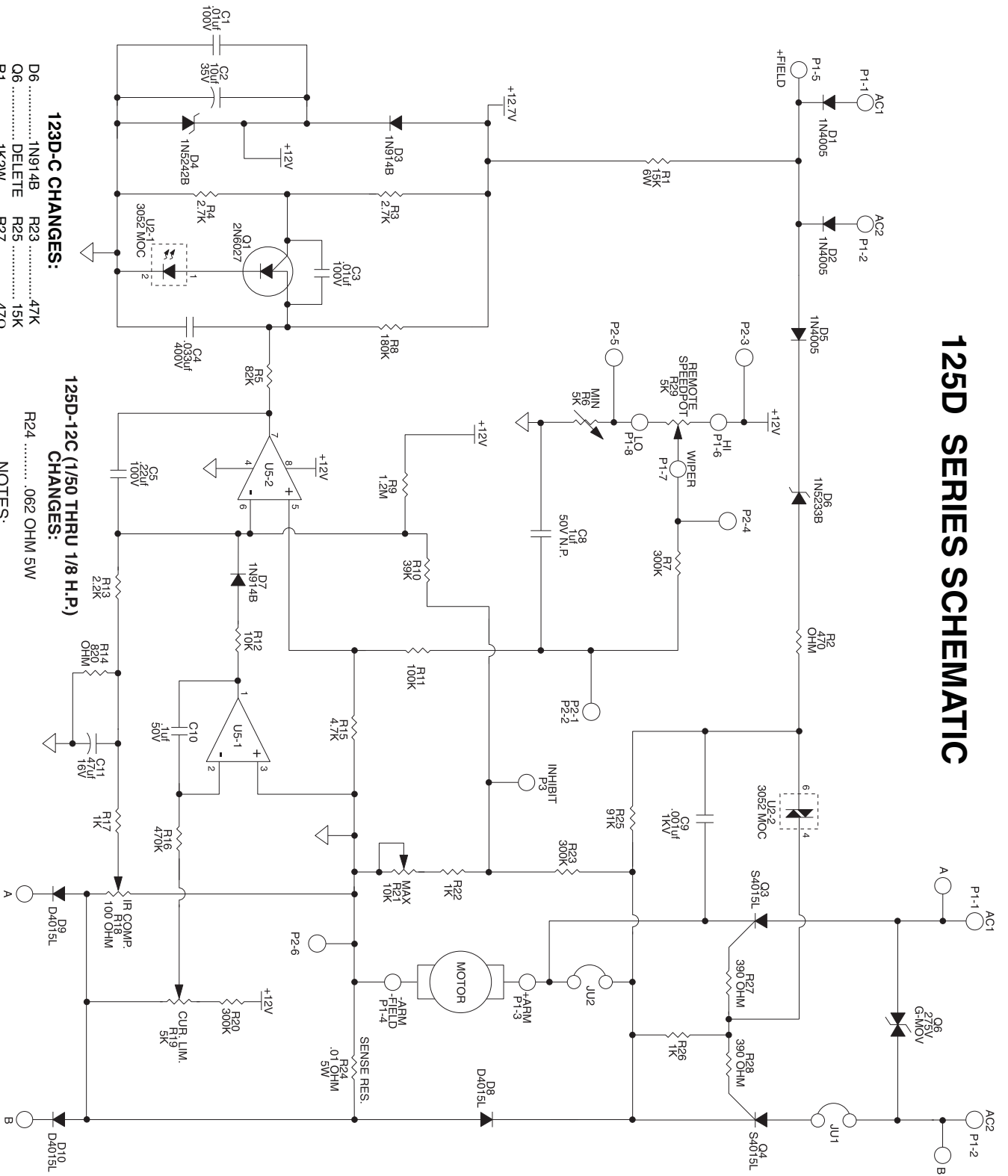

123D-C CHANGES:

- D6 1N914B
- Q6 DELETE
- R1 1K2W
- R2 47Ω
- R16 220K
- R23 47K
- R25 15K
- R27 47Ω
- R28 47Ω

125D-12C (1/50 THRU 1/8 H.P.) CHANGES:

- R24062 OHM 5W

NOTES:

U5 LM358 IC

NOTES:

REPAIR PROCEDURE

In the event that a Product manufactured by Dart Controls Incorporated (DCI) is in need of repair service, it should be shipped, freight paid, to: Dart Controls, Inc., 5000 W. 106th Street, Zionsville, IN. 46077, ATTN: Repair Department. Please include Name, Shipping Address (no P.O. Box), Phone Number and if possible, e-mail address.

Those orders received from anyone without an existing account with DCI must specify if they will be paying COD or Credit Card (Master Card/Visa/American Express). This information is required before work will begin. If you have an account with Dart your order will be processed according to the terms listed on your account. Products with Serial Number date codes over 5 years old will automatically be deemed Beyond Economical Repair (BER). A new, equivalent device will be offered at a substantial discount.

Completed repairs are returned with a Repair Report that states the problem with the control and the possible cause. Repair orders are returned via UPS Ground unless other arrangements are made. If you have further questions regarding repair procedures, contact Dart Controls, Inc. at 317-873-5211.

YOUR MOTOR SPEED CONTROL SOLUTIONS PROVIDER



125D SERIES
AC INPUT - VARIABLE DC OUTPUT
1/50 HP through 1.0 HP



250G SERIES
AC INPUT - VARIABLE DC OUTPUT
1/50 HP through 2.0 HP



65 SERIES
DC INPUT - VARIABLE DC OUTPUT
CURRENT RATINGS OF 20, 40, AND
60 AMPS



700/COMMUTROL SERIES
DC BRUSHLESS
5 & 20 Amp for
12,24,& 36VDC Inputs



MDP SERIES
PROGRAMMABLE
CLOSED LOOP DC
SPEED CONTROL



DM SERIES
FIELD PROGRAMMABLE
DIGITAL TACHOMETER

Dart Controls, Inc. is a designer, manufacturer, and marketer of analog and digital electronic variable speed drives, controls, and accessories for AC, DC, and DC brushless motor applications.

Shown above is just a sampling of the expanded line of Dart controls that feature the latest in electronic technology and engineering. Products are manufactured in the U.S.A. at our Zionsville (Indianapolis,

Indiana) production and headquarters facility - with over 2,000,000 variable speed units in the field.

In addition to the standard off-the-shelf products, you can select from a wide variety of options to customize controls for your specific application. For further information and application assistance, contact your local Dart sales representative, stocking distributor, or Dart Controls, Inc.

Dart Controls, Inc.

Manufacturer of high quality DC and AC motor speed controls and accessories since 1963.

P.O. Box 10
5000 W. 106th Street
Zionsville, Indiana 46077
Phone: (317) 873-5211
Fax: (317) 873-1105