

**MD10P Motor Stall;
Drive Shutoff and Alarm Concept**
(this will work with all MD Series – some terminal designations may change – see User Manual)

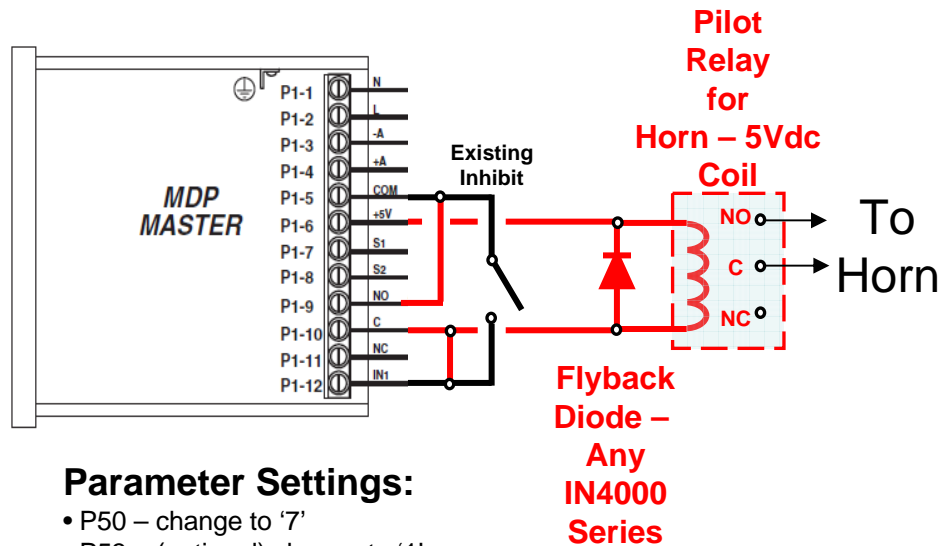

Option 1 - Audible Alarm All Inhibit Conditions



Parameter Settings:

- P50 – change to '7'
- P53 – (optional) change to '1'
- P57 – change to 'X', where
is equal # seconds of stall
until alarm activates

Option 2 - Audible Alarm Only On Motor Stall Condition

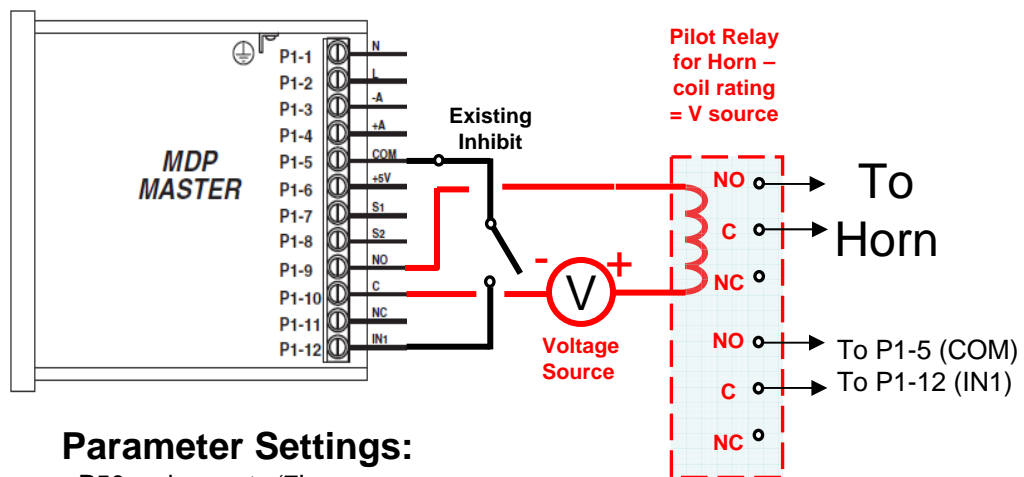

Parameter Settings:

- P50 – change to '7'
- P53 – (optional) change to '1'
- P57 – change to 'X', where
is equal # seconds of stall
until alarm activates