

ASP Plus Series Smart Speed Pot for Any* Drive

*must accept a 3-wire speed pot input



Performance matched with
Dart's PU Series Encoder

The **ASP PLUS Series** is the latest development from Dart in the area of SMART speed pots.

A SMART speed pot is:

- Digital
- Programmable
- Closed-loop
- Multi-function
- Multi-mode

The ASP PLUS is ideal for applications where a remote PLC/SCADA system sends the motor drive a set speed.

The ASP PLUS works in conjunction with any drive by providing an isolated input for the PLC/SCADA command, using encoder feedback closes the motor loop to maintain tight speed regulation, and sends analog or serial communication data back to the supervisory system to verify actual motor speed. Along with motor not running indication, remote stop and Auto/Manual control modes the ASP PLUS packs all these features in one small package eliminating installation space and labor costs.

The ASP PLUS is a real problem solver for plant maintenance, system integrator and OEM equipment designers.

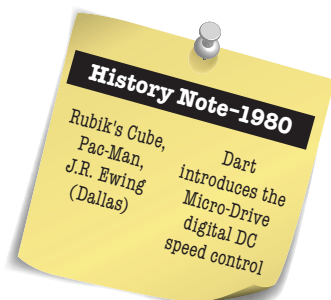

ASP PLUS STANDARD FEATURES

- Microprocessor-based design allows for incredible flexibility to suit your process control needs
- ModularBus expansion makes it possible for the Accu-Set plus to accommodate a wide variety of I/O
- Digital closed-loop algorithm ensures accuracy of $\pm 1/2$ RPM of set speed or equivalent
- Digital open-loop operation available, where a speed pickup is impractical or undesired
- Non-volatile memory stores settings without batteries, even when power has been removed
- Factory or field programmable via front-panel keypad
- Many adjustable settings include min, max, accel, decel, display options, alarm options, and more
- Internal program-enable jumper selectively prevents tampering with unit's configuration
- Universal power supply accepts any line voltage inputs from 85-250VAC @ 50-60Hz without switches or jumpers. The unit automatically adjusts as needed.
- Transient voltage protection prolongs unit's life in harsh industrial environments
- Speed pickup input compatible with a variety of signal input types including: Hall-Effect Pickups, Photoelectric, TTL, etc.
Note: Open collector devices must be capable of sinking at least 3mA
- Self-contained power supply for external speed pickups, limited to 5V @ 50mA
- Two separate programmable alarm outputs w/Form C contacts
- Flexible user inputs support Inhibit, Emergency-Stop, and Jog functionality
- Large 4 digit, 1/2" LED display, with user-settable decimal point (colon displayed in Time mode)
- Durable NEMA 4/4X rated aluminum housing with Polycarbonate membrane and gasket (which are included) meet NEMA 4X standards when used with NEMA 4X enclosures
- European-style 5mm terminal block or pluggable terminal block available
- cULus approval pending
- Wide operating ambient temperature range of -10°C to 45°C (14°F to 113°F)
- Multiple operating modes are available in closed-loop operation, including:
 - Master, Rate Mode – Controls in rate unit such as RPM, Gallons per Second, etc.
 - Master, Time Mode – Controls in time units such as HH:MM, MM:SS, SS:TT
 - Follower Mode – Controls in percentage of master rate

ASP PLUS SELECTION GUIDE

MODEL	INPUT @ 50-60HZ	ENCODER REQUIRED?	4-20mA OUTPUT?
ASP40	85-250VAC	Yes	No
ASP40-420	85-250VAC	Yes	Yes

DIMENSIONAL SPECIFICATIONS

MODEL	WIDTH	HEIGHT	DEPTH
<i>ASP40/ASP40-420 English (inches)</i>			
Housing	3.620	1.656	4.625
Lens	4.539	2.289	0.375
<i>ASP40/ASP40-420 Metric (millimeters)</i>			
Housing	91.95	42.06	117.47
Lens	115.29	58.14	9.52

SPECIFICATIONS

Signal Input Voltage Range	5VDC to 24VDC (square wave, referenced to P1-6 COMMON)
Speed Pickup	
Input Frequency (S1 and S2 Inputs)	0 – 600,000 Pulses per Minute @ 5V square wave
Display Range	0.001 – 9,999
"Engineering Units"	User Programmable, any Units
Sensor / Pickup Power Supply	5V @ 50mA
ASP40 Isolated Alarm Relay Output Rating	250VAC @ 5A
OPT420 Isolated Alarm Relay Output Rating	50VAC @ 1A
Voltage Difference between PotLo and PotHi Inputs	2VDC to 24VDC
Pot Wiper Output voltage range	PotLo +50mVDC to PotHi – 50mVDC

OPERATING CONDITIONS

Temperature -10° to +45° C.

ASP PLUS HOOK-UP – MASTER AND FOLLOWER

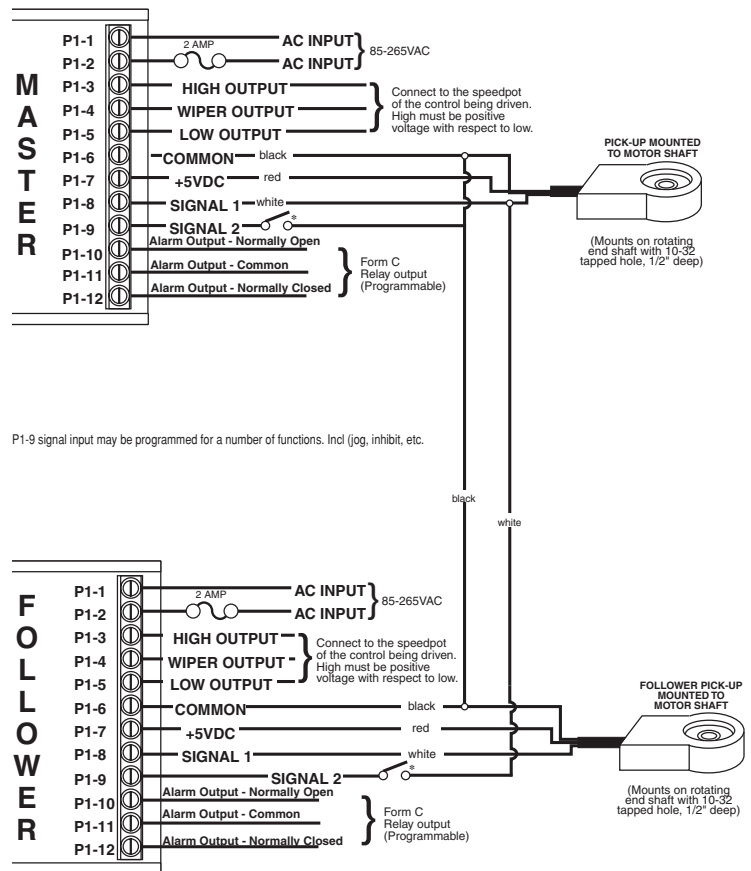

* Optional Inhibit Switch