



## ACCU-SET II SERIES STANDARD FEATURES

- Compact 1/8 DIN aluminum housing for panel mounting
- Microprocessor based
- Field Programmable operating parameters
- Displays actual or desired speed directly in RPM, FPM, process time, or other engineering units
- P-I-D digital closed loop control; gains settable for optimum system performance; Fast settling time
- Accuracy  $\pm 1/2$  RPM of set speed
- Master/Follower operation
- Variety of pick-up inputs; Hall-Effect, Photoelectric, or any TTL; accepts up to 1.2 million pulses/min. maximum
- Non-volatile memory retains speed setting and all field programmable parameters
- Internal A/D interface permits using potentiometer, 4 to 20 mA or 0 to +5 VDC signal in lieu of digital pick-up signal or to control target speed, current program or frequency generator output
- Inhibit circuit permits start and stop without breaking AC lines; pre-selecting speed, or simultaneous start-up of multiple control units
- Up/down pushbuttons for set points - slow-fast sweep; front panel lockout prevents accidental setting changes
- Self-contained power supply for transducer (+5V, 50mA)
- Exclusive user assignable outputs - to drive relays, alarms, etc. Can be activated by any combination of conditions; upper speed limit exceeded, etc.
- Independent frequency generator allows units to produce own leader frequency.
- Barrier type terminal strip
- G.E. Lexan™ membrane seals faceplate from environment
- Multi-mode of operation allows multiple constants, settings, and upper/lower limits. Up to six different configurations can be selected from the front panel via the up/down pushbutton switches

## PROGRAMMING FEATURES

- All programming from front panel "Menu Driven"
- User selectable "programming protect" prevents unauthorized access
- LED function indicators
- Programmable parameters include:
  - Lower/upper limits for speed setting
  - Accel/decel 0 to 30 seconds for 0-1000 RPM change
  - Pick-up pulses per revolution
  - P-I-D gain settings
  - Constants to allow display in desired user engineering units—rate or time
  - Decimal point or colon
  - "Stall detector" time-out for annunciation and shutdown
  - Multiple programs permit up to six different desired set-ups to be programmed
  - Selectable display blanking point
  - Operation mode (master rate, master time, standard follower, network follower)
  - Unit address for multiple control networking
  - Selectable serial communication rate
  - Front panel lockout for speed setting and/or program changes
  - Numerous other features

## Accu-Set II Series Smart Speed Potentiometer for Use with Conventional AC Frequency or DC Drives

The Accu-Set II Series digital control unit, with an advanced 16-bit Microprocessor, is designed for use with conventional AC frequency or DC drives, any horsepower, to provide: LED display of set or actual speed, closed loop motor speed control, Master or Follower modes, and Serial communications.

**The Accu-Set II Series is a companion control to the Accu-Set Series, while offering significantly improved performance.** This control features a *true* P-I-D algorithm, for extremely responsive and precise control over a wide variety of desired speeds and applications.

Set or actual speed is displayed directly in RPM, FPM, Process Time, or other engineering units. Field programming permits customizing specific operating parameters.

The integrated RS485/RS422/RS232 serial interface port is perfect for monitoring or control using almost any computer or process controller. Units can even be attached in a Local Area Network, and can then be controlled and programmed either individually or all at once. Multiple programs allow the user to choose between a "menu" of up to six programmed configurations.

**The Accu-Set II Series is ideally suited for commercial or industrial applications, including system up-grades.**

## COMMUNICATION FEATURES

- RS485; RS422; RS232 serial interface port for remote monitoring/control/programming allows the following:
  - Continuous output of actual shaft speed
  - Remote speed setting
  - Programming or listing of all field programmable parameters
  - Dartnet network allows multiple controls to be attached via one cable. Controls can be individually programmed or integrated.
  - Programmable communication baud rate for 300 to 9600 baud
  - Network Follower mode allows widely remote controls to be followed together over single RS485 twisted pair wire or over existing network

## ACCU-SET II SERIES ASP20 SELECTION GUIDE

| MODEL | INPUT       | DISPLAY UNITS | STD. SPEED RANGE    |
|-------|-------------|---------------|---------------------|
| ASP20 | 120/240 VAC | Rate or Time  | Field Programmable* |

Requires Dart PU-E or other pick-up.

\* Shipped set for 0 - 3600 RPM with one pulse per revolution.

## OPERATING SPECIFICATIONS

|                              |                                       |
|------------------------------|---------------------------------------|
| Temperature.....             | -10° to +45° C.                       |
| AC input voltage.....        | 85–265 VAC                            |
| Input frequency.....         | 50/60 Hz.                             |
| Transducer signal input..... | 0-5 to 0-24 VDC                       |
| On-board power supply.....   | 5 VDC, 50mA<br>(for external sensors) |

## MOUNTING SPECIFICATIONS - ASP20

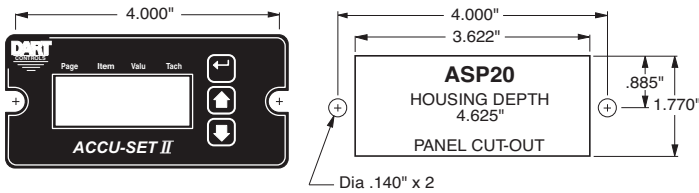

## DIMENSIONAL SPECIFICATIONS

| MODEL   | WIDTH                | HEIGHT        | DEPTH          |
|---------|----------------------|---------------|----------------|
| ASP20   | inches (millimeters) |               |                |
| Housing | 3.620 (91.95)        | 1.656 (42.06) | 4.625 (117.47) |
| Lens    | 4.539 (115.29)       | 2.289 (58.13) | 0.375 (9.52)   |

## OPTION DESCRIPTION

| OPTION                            | SUFFIX |
|-----------------------------------|--------|
| Magnetic pick-up input board..... | -3     |
| Blank Lexan.....                  | -9     |

## HOOK-UP DIAGRAMS - ASP20

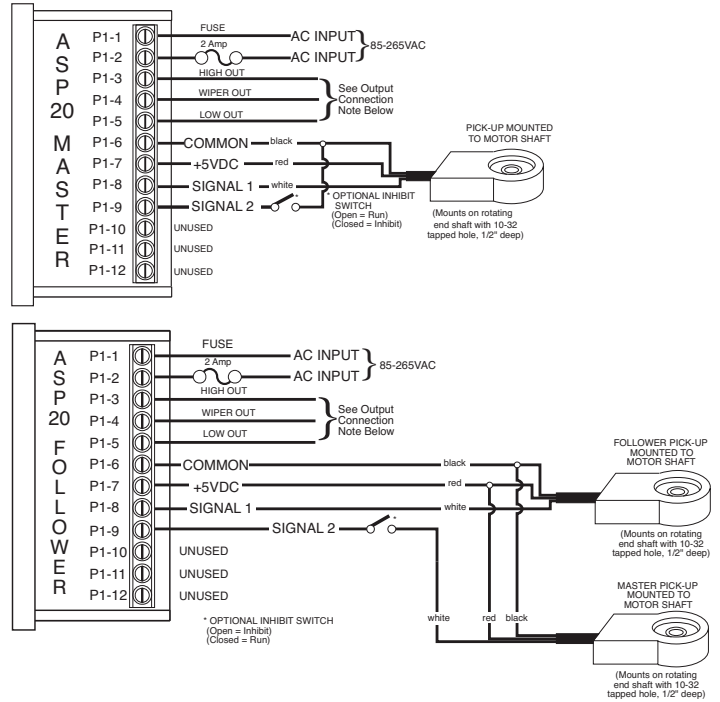

### OUTPUT CONNECTION NOTE:

Connect to Speedpot input of the device being driven (P1-3 must be positive in respect to P1-5). If driven device has a positive supply, connect P1-3 to the Positive supply terminal (Pot High) and set Page 7 Item 11 -see ASP20/MD20 instruction manual- to a value of zero. If driven device has a negative power supply, connect P1-3 to the Common terminal (Pot Low) and set Page 7 Item 11 to a value of 1.

### HOOK-UP PROCEDURE:

STEP 1: Connect the proper input voltage to P1-1 and P1-2.

NOTE: Fusing should be added in the AC line to protect the control. A 2 amp fuse is recommended.

STEP 2: Connect the PU-E as shown in hook-up diagram above.  
STEP 3: Wire the pot output of the ASP20 to the control being driven.

STEP 4: You are now ready to apply power to your system.

**NOTE: Shielded cable is recommended for applications where pick-up cord length is in excess of 6 feet.**

Connect the shield to the common terminal of the ASP20, leaving the shield at the pick-up end floating.

**CAUTION: When pick-up signal is lost, a master ASP20 will run at full speed, while a follower ASP20 will go to zero speed.**

## ACCU-SET SERIES CONFIGURATIONS

