

65 Series Battery Operated DC Motor Speed Control

65E60



65E40/65E20

65E10



Speed Potentiometer
Kit Included

The 65 Series controls are high performance PWM controls for 12, 24, and 36 volt battery powered equipment providing smooth control with high efficiency operation. The advanced design permits a substantial increase in the equipment running time between charges over conventional techniques. Features include adjustable maximum speed, minimum speed, current limit, I.R. compensation, and acceleration. The adjustable current limit feature protects the control, battery, and motor from sustained overloads. The higher capacity models also provide thermal protection.

Dart's 65 Series controls are designed for heavy duty battery operated PM motor applications, such as: floor scrubbers, small personnel carriers, AGV's, agricultural sprayers and a vast variety of portable equipment.

The newest addition to the 65 Series is the 65E10. Rated for 10 amps continuous current, the 65E10 is packaged in the same compact industry standard footprint as Dart's popular 125 Series DC speed control. The 65E10 also features a quiet operating frequency of 18 kHz.

All the 65 Series controls come standard with a speed pot, knob, and dial plate.

65 SERIES STANDARD FEATURES

- Provides smooth variable speed capability for mobile equipment
- Increases range or running time of battery operated equipment through high efficiency
- Allows reduction in battery size w/out loss of operating range
- Automatic compensation to allow for declining battery voltage
- Speed regulation is $\pm 1\%$ of base speed
- Adjustable maximum speed
- Adjustable minimum speed
- Adjustable I.R. compensation
- Adjustable current limit
- Adjustable acceleration speed
- Maintains variable speed control as batteries discharge
- 5K ohm speedpot with leads, knob and dial included
- Speed adjustment using 5K ohm speedpot or 0-10 VDC analog input signal
- Inhibit terminal permits optional start-stop without breaking battery line

65 SERIES SELECTION GUIDE

MODEL NUMBER	CONTINUOUS CURRENT
<i>12 VDC Input, 0-12 VDC Output</i>	
65E10-12	10 Amps
65E20-12	20 Amps
65E40-12	40 Amps
65E60-12	60 Amps
<i>24/36 VDC Input, 0-24/0-36 VDC Output</i>	
65E10	10 Amps
65E20	20 Amps
65E40	40 Amps
65E60	60 Amps

OPERATING CONDITIONS

Operating Temperature..... -10° C to +45° C (14°F to 113°F)
 Input Frequency D.C.

DIMENSIONAL SPECIFICATIONS

MODEL	WIDTH	LENGTH	DEPTH	WEIGHT
English (inches) Metric (centimeters)				
65E10	3.625 9.21	4.25 10.76	1.30 3.30	6.0 oz. 170 gm.
65E20	3.70 9.40	7.00 17.78	1.70 4.32	10.5 oz. 297 gm.
65E40	3.70 9.40	7.00 17.78	1.70 4.32	13.4 oz. 297 gm.
65E60	6.70 17.02	9.00 22.86	2.27 5.77	34.0 oz. 962 gm.

65E10 HOOK-UP DIAGRAM

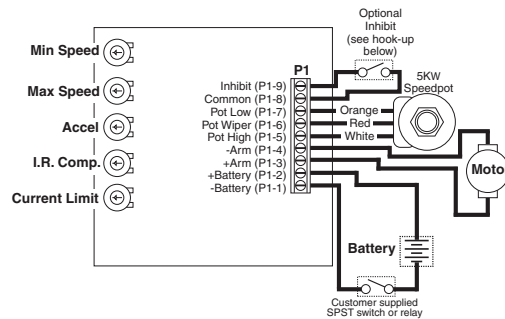

65E20/40/60 HOOK-UP DIAGRAM

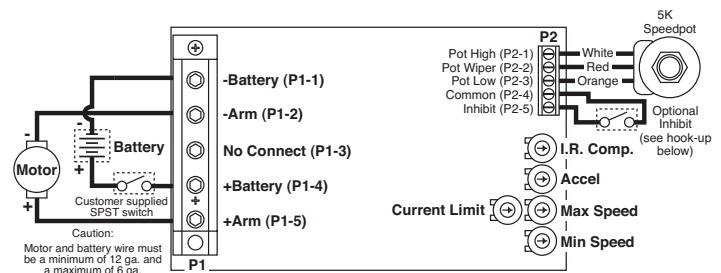

65 SERIES SPECIFICATIONS

	65E10	65E20	65E40	65E60
Load Current (continuous)	10 Amps	20 Amps	40 Amps	60 Amps
Speed Adjustment	5K ohm potentiometer or 0 to +10V DC input signal			
Overload Capacity	200% for 10 seconds; 150% for 1 minute			
Speed Range	30:1			
Current Limit	Adjustable 100% to 200% of full motor load, up to continuous current rating (see above)			
Acceleration	Adjustable - 0 to 10 sec.			
Deceleration	Non-adjustable - 0.5 sec.			
Maximum Speed	Adjustable - 50 to 100% of base speed			
Minimum Speed	Adjustable - 30% of max speed			
Input/Output Connections	Barrier Terminal Block / 12 Ga. to 6 Ga. maximum			
Speed Regulation	1% of base speed			
Package Configuration	Black anodized aluminum extrusion			
Internal Operating Frequency	18K Hertz	Approximately 800 Hz.		
Thermal Protection	Not Available	Current foldback at 80°C. heatsink temperature		