

65E CONTROL SERIES

DART

CONTROLS

Instruction Manual

For DC Input Variable Speed Controls



**P.O. Box 10
5000 W. 106th Street
Zionsville, Indiana 46077**

**Phone (317) 873-5211
Fax (317) 873-1105
www.dartcontrols.com**

TABLE OF CONTENTS

WARRANTY	1
STANDARD FEATURES	1
CONTROL DIMENSIONS	1
MOUNTING DIMENSIONS	2
INSTALLATION	2
HOOK-UP DIAGRAMS	2-3
INHIBITING THE CONTROL	3
TRIMPOT ADJUSTMENTS	3-4
IN CASE OF DIFFICULTY	4
MODEL SELECTION	4
SPECIFICATIONS	4
65E SERIES PARTS PLACEMENT & LIST	5
65E SERIES SCHEMATIC	6
REPAIR PROCEDURE & PRODUCT LINE	BACK COVER

WARRANTY

Dart Controls, Inc. (DCI) warrants its products to be free from defects in material and workmanship. The exclusive remedy for this warranty is DCI factory replacement of any part or parts of such product which shall within 12 months after delivery to the purchaser be returned to DCI factory with all transportation charges prepaid and which DCI determines to its satisfaction to be defective. This warranty shall not extend to defects in assembly by other than DCI or to any article which has been repaired or altered by other than DCI or to any article which DCI determines has been subjected to improper use. DCI assumes no responsibility for the design characteristics of any unit or its operation in any circuit or assembly. This warranty is in lieu of all other warranties, express or implied; all other liabilities or obligations on the part of DCI, including consequential damages, are hereby expressly excluded.

NOTE: Carefully check the control for shipping damage. Report any damage to the carrier immediately. Do not attempt to operate the drive if visible damage is evident to either the circuit or to the electronic components.

All information contained in this manual is intended to be correct, however information and data in this manual are subject to change without notice. DCI makes no warranty of any kind with regard to this information or data. Further, DCI is not responsible for any omissions or errors or consequential damage caused by the user of the product. DCI reserves the right to make manufacturing changes which may not be included in this manual.

WARNING

Improper installation or operation of this control may cause injury to personnel or control failure. The control must be installed in accordance with local, state, and national safety codes. Make certain that the power supply is disconnected before attempting to service or remove any components!!! If the power disconnect point is out of sight, lock it in disconnected position and tag to prevent unexpected application of power. Only a qualified electrician or service personnel should perform any electrical troubleshooting or maintenance. At no time should circuit continuity be checked by shorting terminals with a screwdriver or other metal device.

STANDARD FEATURES

- Provides smooth variable speed capability for mobile equipment
- Maintains variable speed control as batteries discharge
- Adjustable maximum speed, minimum speed, current limit, I.R. compensation, and accel
- Inhibit terminal permits optional start-stop without breaking battery lines
- Speed potentiometer, knob, and dialplate included
- Increases range or running time of battery operated equipment through high efficiency
- 65E40 and 65E60 series only - Automatic current limit foldback decreases current limit to 50% of setpoint when heatsink temperatures reach 80° C. - provides protection from overheating

CONTROL DIMENSIONS

MODEL	WIDTH	LENGTH	DEPTH	WEIGHT
	inches (centimeters)			oz. (gms.)
65E20	3.7 (9.40)	7.0 (17.8)	1.70 (4.32)	10.5 (297)
65E40	3.7 (9.40)	7.0 (17.8)	1.70 (4.32)	13.4 (379)
65E60	6.7 (17.1)	9.0 (22.9)	2.27 (5.77)	34.0 (962)

MOUNTING DIMENSIONS

65E20 & 65E40 MOUNTING

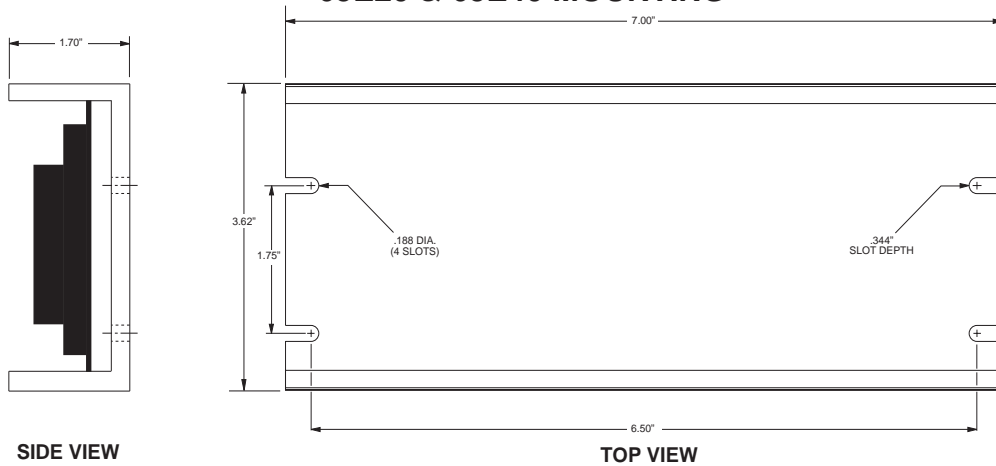

65E60 MOUNTING

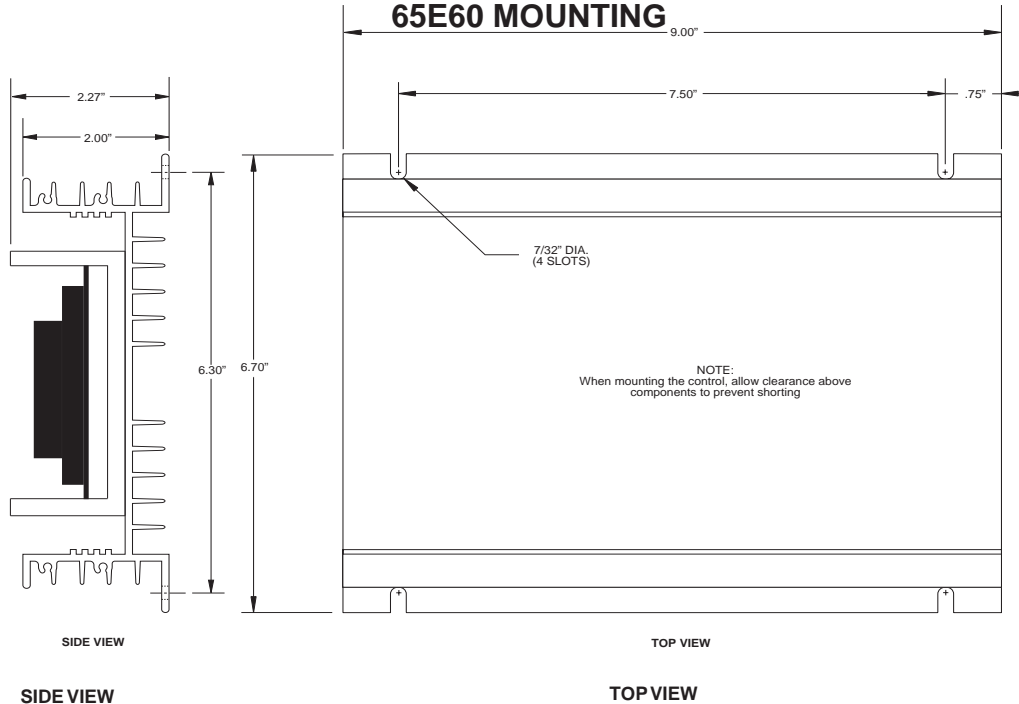

Caution: Do not mount controller where ambient temperature is outside the range of -10° C (15° F) to 45° (115° F).

INSTALLATION

Before attempting to wire the control, make sure all power is disconnected. Recheck code designation to assure proper voltage is present for the control. Caution should be used in selecting proper size of hook-up wire for current and voltage drop. Note: the battery and armature wire size on 65E models must be a minimum of 12 gauge.

HOOK-UP DIAGRAMS

**WARNING:
DO NOT REVERSE POSITIVE AND NEGATIVE BATTERY LEADS. THIS WILL DAMAGE THE CONTROL.
TO CHANGE MOTOR DIRECTION, INTERCHANGE THE POSITIVE AND NEGATIVE ARMATURE LEADS.**

Refer to the wiring diagrams below for proper connection of **DC Voltage**, **Armature**, and **Speedpot wiring** to the control.

CAUTION !! TURN POWER OFF WHILE MAKING CONNECTIONS .

To properly adjust the CURRENT LIMIT setting, a DC ammeter should be placed in series with the armature line. This meter can be removed after the control is adjusted.

65E SERIES HOOK-UP DIAGRAM

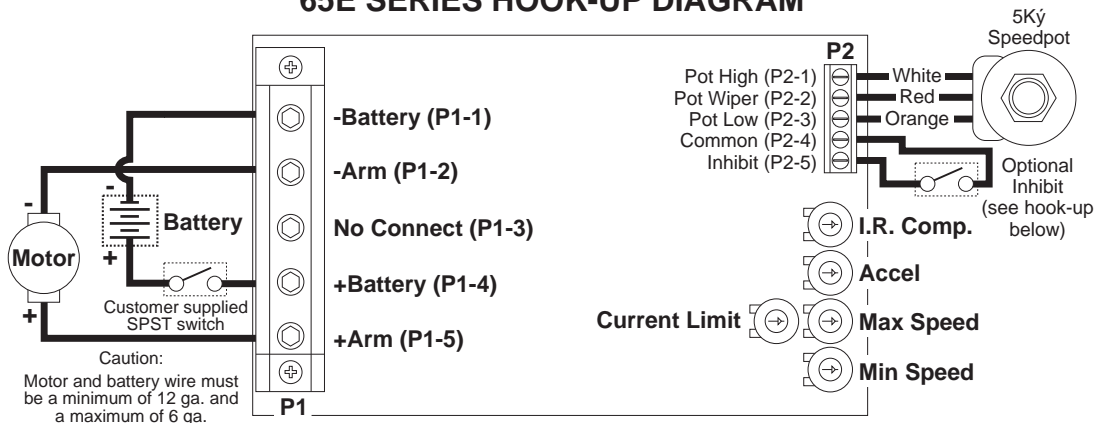

65E REVERSING HOOK-UP DIAGRAM

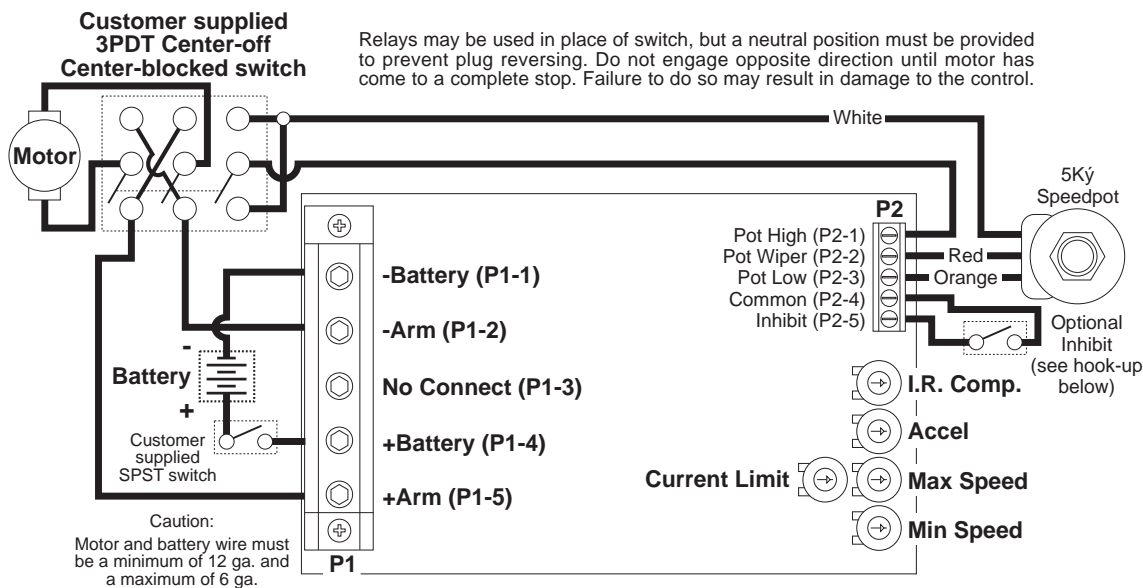

INHIBITING THE CONTROL

Using inhibit input - provide fast start-stop by bypassing accel/decel circuit

Inhibit via speedpot - provides starting and stopping through accel/decel parameters

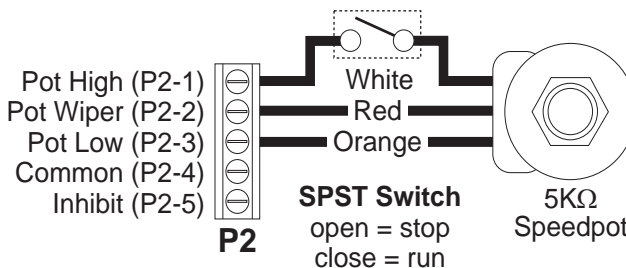
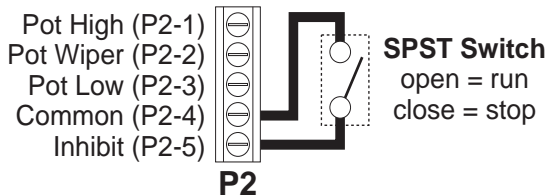

Note: Always use a shielded cable when connecting to the inhibit terminal. The shield of the cable should connect to the Common terminal of the control.

TRIMPOT ADJUSTMENTS

Before the power is applied, the speed potentiometer and trimpots should be preset as follows:

TRIMPOT PRESET

1. Preset speedpot fully CCW, preset Max trimpot CW 1/2 way, preset Current Limit trimpot fully CW, preset Min trimpot fully CCW, preset Accel trimpot CW 1/2 way, preset I.R. trimpot fully CW.

DC power can now be applied to the system and the control adjusted as directed below:

TRIMPOT ADJUSTMENT

2. Increase the **MIN** trimpot in a clockwise direction until the desired minimum speed is reached.
3. Turn the Speedpot fully clockwise and adjust the **MAX** trimpot until the desired maximum speed is reached.

(continued)

4. Adjust the **ACCEL** trimpot to achieve the desired soft start time. CW rotation will increase accel time.
5. Rotate the **CURRENT LIMIT** trimpot fully CCW until the motor begins to stall. Apply a full load to the motor. While motor is stalled adjust the **CURRENT LIMIT** trimpot CW until a desired current setting is obtained.
6. Adjust I.R. trimpot CW 1/2 way. If motor RPM is inconsistent (jumpy), rotate I.R. trimpot CCW until rotation is stable.

IN CASE OF DIFFICULTY

If a newly installed control will not operate, it is likely that a terminal or connection is loose. Check to make sure connections are secure and correct. If the control is still inoperative, refer to the following chart for reference:

PROBLEM	POSSIBLE CAUSE(S)	CORRECTIVE ACTION
Motor doesn't run	<ul style="list-style-type: none"> • Incorrect or no power • Speedpot set at zero • Worn motor brushes • Current limit set too low 	Install proper service Rotate speedpot fully CW Replace motor brushes Adjust current limit trimpot CW
Motor "hunts"	<ul style="list-style-type: none"> • Max trimpot set too high • I.R. Comp. trimpot set too high 	See "Trimpot Adjustments" - page 3-4 See "Trimpot Adjustments" - page 3-4
Motor runs at "full speed" uncontrollable	<ul style="list-style-type: none"> • Loose speedpot connections • Min. or Max. trimpots not properly adjusted • Possible control failure 	Secure all connections See "Trimpot Adjustments" - page 3-4 Send to Dart Controls, Inc.
Motor rotates in wrong direction	<ul style="list-style-type: none"> • Motor armature hooked up backwards 	Reverse armature + and - leads
Motor stalls under a light load	<ul style="list-style-type: none"> • Current limit trimpot improperly adjusted 	See "Trimpot Adjustments" - page 3-4

MODEL SELECTION

INPUT VOLTAGE	OUTPUT VOLTAGE	CONTINUOUS CURRENT	MODEL NUMBER
12 VDC ± 15%	0 - 12 VDC	20 amps D.C.	65E20-12
12 VDC ± 15%	0 - 12 VDC	40 amps D.C.	65E40-12
12 VDC ± 15%	0 - 12 VDC	60 amps D.C.	65E60-12
24 VDC ± 15%	0 - 24 VDC	20 amps D.C.	65E20*
24 VDC ± 15%	0 - 24 VDC	40 amps D.C.	65E40*
24 VDC ± 15%	0 - 24 VDC	60 amps D.C.	65E60*
36 VDC ± 15%	0 - 36 VDC	20 amps D.C.	65E20*
36 VDC ± 15%	0 - 36 VDC	40 amps D.C.	65E40*
36 VDC ± 15%	0 - 36 VDC	60 amps D.C.	65E60*

* 24 volt and 36 volt units with the same current ratings are interchangeable (ie. 24 volt unit will operate with 36 volt input and a 36 volt unit will operate with 24 volt input, same current rating).

SPECIFICATIONS

	65E20	65E40	65E60
Load current (continuous)	20 amps	40 amps	60 amps
Speed adjustment	5K Ω potentiometer or 0 to +10VDC input signal		
Speed range	30 : 1		
Overload capacity	200% for 10 seconds; 150% for one minute		
Current limit	adjustable 100% to 200% of full motor load, up to continuous current rating (page 4)		
Acceleration	adjustable - 0 to 10 seconds		
Deceleration	non-adjustable - 0.5 seconds		
Maximum speed	adjustable - 50 to 100% of base speed		
Minimum speed	adjustable - 30% of max speed		
Connections	barrier terminal block (12Ga. to a maximum 6 Ga.)		
Speed regulation	1% of base speed via adjustable I.R. Compensation trimpot		
Operating temperature	-10°C to +45°C (14°F to 113°F)		
Package configuration	black anodized aluminum extrusion		
Internal operating frequency	approximately 1.6K Hertz		
Thermal protection	N/A	Current foldback at 80° C. heatsink temperature	

65E40 / 65E60 PART PLACEMENT & LIST

RESISTORS

R1	300Ω 5W
R2	47K
R3	470Ω
R4	47K
R5	470Ω
R6	10K
R7	20K MAX
R8	33K
R9	220K
R10	47K
R11	10K
R12	100K
R13	10K
R14	180K
R15	250K ACCEL
R16	20K 1/4W 1%
R17	470K
R18	300K
R19	47K
R20	5K MIN
R21	82K
R22	10K
R23	4.7K
R24	6.8K
R25	10K
R26	4.7K
R27	47K
R28	10K
R29	300K
R30	20K CUR. LIM.
R31	4.7K
R32	5K I.R. COMP
R33	100K
R34	47K
R35	2.7K
R36	22Ω
R37	22Ω
R38	22Ω
R39	22Ω
R40	22Ω
R41	22Ω
R42	47K
R43	1.2M
R44	150Ω
R45	5K SPEEDPOT*
R46	22K
R47	680K
R48	2.7K
R49	100K
R50	100K
R51	15K

CAPACITORS

C1	.1μF 63V
C2	.1μF 63V
C3	.22μF 100V
C4	.1μF 63V
C5	.1μF 63V
C6	.22μF 100V
C7	.1μF 63V
C8	.01μF 100V
C9	.01μF 100V
C10	47μF 16V
C11	1000μF 50V
C12	1000μF 50V
C13	.1μF 63V
C14	.1μF 63V
C15	.01μF 100V

DIODE

D1	1N4005
D2	1N4005
D3	1N5349B
D4	1N963B
D5	1N914B
D6	1N5233B
D7	1N914B

ACTIVE DEVICES

Q1	IRFZ44
Q2	IRFZ44
Q3	IRFZ44
Q4	IRFZ44
Q5	IRFZ44
Q6	IRFZ44
Q7	IRFZ44
Q8	IRFZ44
Q9	IRFZ44
Q10	IRFZ44

IC PACKAGES

U1	40106 IC
U2	LM324 IC
U3	LM324 IC
U4	LM358 IC

MISCELLANEOUS

PCB	A-4-2519B PRINTED CIRCUIT BOARD
P1 (-1 thru -5)	5 POS. TERMINAL BLOCK
P2 (-1 thru -5)	5 POS. BARRIER TERMINAL STRIP
RL1	RLB2508X RAIL
RL2	RLPRN910 RAIL
RL3	RLB25011XB RAIL
SW1	67F080 TEMP. SWITCH

65E20-12 CHANGES:

C12	DELETE
Q1	DELETE
Q2	DELETE
Q3	DELETE
Q4	DELETE
Q7	DELETE
Q9	DELETE
Q10	DELETE
R1	10Ω 1W
R6	22K
R28	4.7K
R31	2.2K
R35	1K
R42	22K
R48	1K

65E20 CHANGES:

C12	DELETE
Q1	DELETE
Q2	DELETE
Q3	DELETE
Q4	DELETE
Q7	DELETE
Q9	DELETE
Q10	DELETE
R48	1K

65E40/60-12 CHANGES:

R1	10Ω 1W
R6	22K
R31	2.2K
R35	1K
R42	22K
R48	1K

* SPEEDPOT IS MOUNTED REMOTE
NOTE: ALL RESISTORS 1/8W UNLESS NOTED OTHERWISE

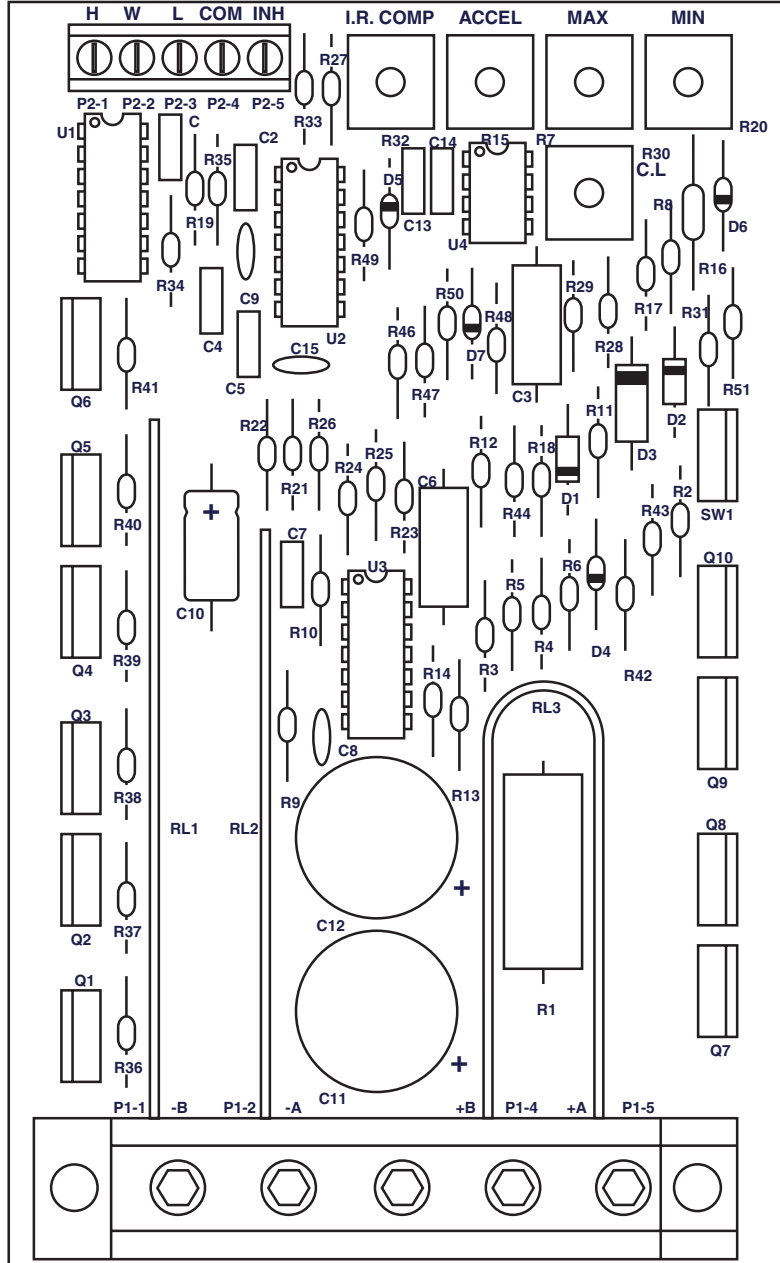

65E SERIES SCHEMATIC

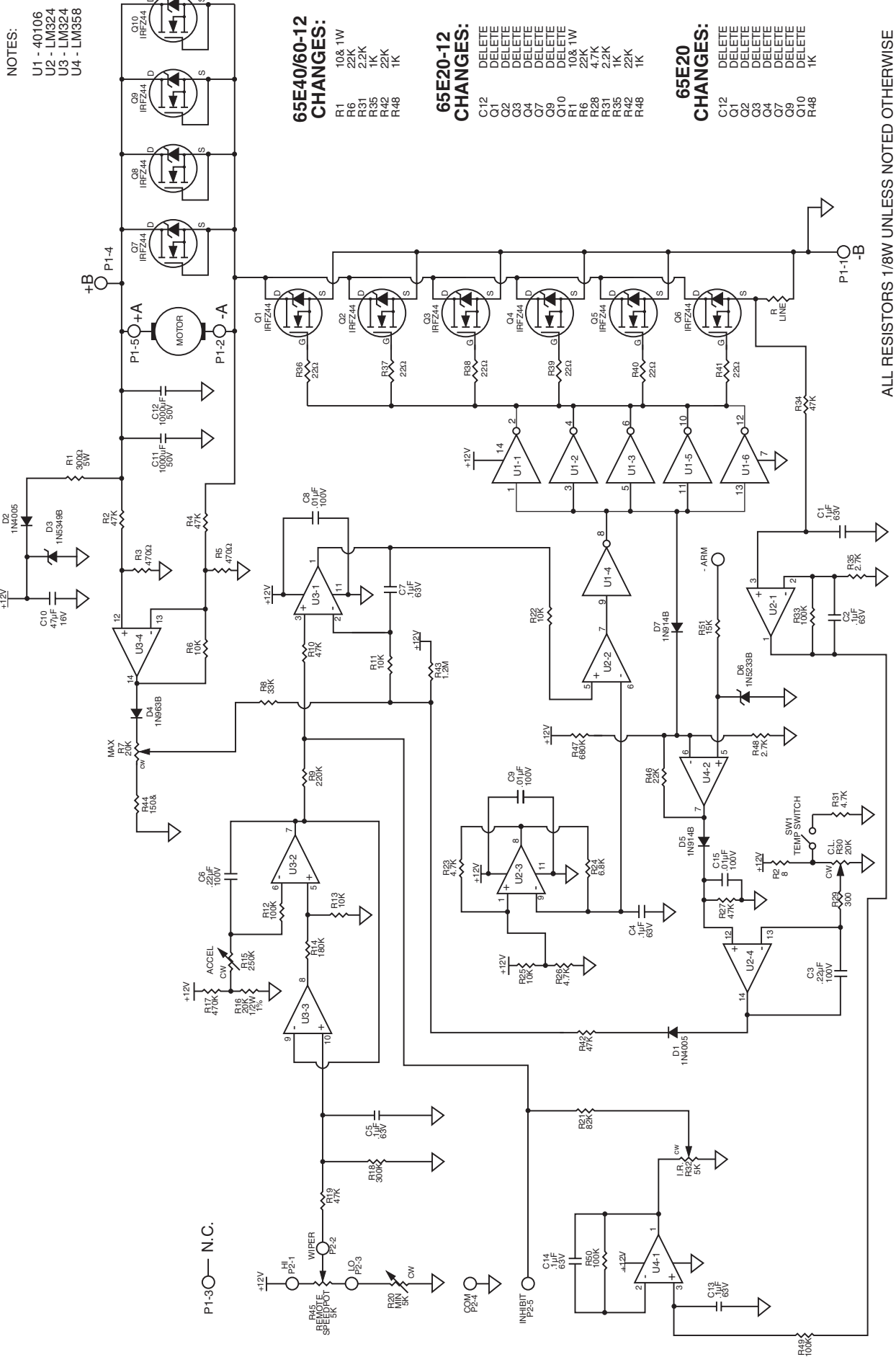

NOTES:
 U1 - 40106
 U2 - LM324
 U3 - LM324
 U4 - LM358

65E40/60-12 CHANGES:
 R1 10Ω 1W
 R6 22Ω
 R31 22K
 R35 1K
 R42 22K
 R48 1K

65E20-12 CHANGES:
 C12 DELETE
 Q1 DELETE
 Q2 DELETE
 Q3 DELETE
 Q4 DELETE
 Q7 DELETE
 Q9 DELETE
 Q10 DELETE
 R1 10Ω 1W
 R6 22Ω
 R28 4.7K
 R31 22K
 R35 1K
 R42 22K
 R48 1K

65E20 CHANGES:
 C12 DELETE
 Q1 DELETE
 Q2 DELETE
 Q3 DELETE
 Q4 DELETE
 Q7 DELETE
 Q9 DELETE
 Q10 DELETE
 R48 1K

ALL RESISTORS 1/8W UNLESS NOTED OTHERWISE

REPAIR PROCEDURE

In the event that a Product manufactured by Dart Controls Incorporated (DCI) is in need of repair service, it should be shipped, freight paid, to: Dart Controls, Inc., 5000 W. 106th Street, Zionsville, IN. 46077, ATTN: Repair Department. Please include Name, Shipping Address (no P.O. Box), Phone Number and if possible, e-mail address.

Those orders received from anyone without an existing account with DCI must specify if they will be paying COD or Credit Card (Master Card/Visa/American Express). This information is required before work will begin. If you have an account with Dart your order will be processed according to the terms listed on your account. Products with Serial Number date codes over 5 years old will automatically be deemed Beyond Economical Repair (BER). A new, equivalent device will be offered at a substantial discount.

Completed repairs are returned with a Repair Report that states the problem with the control and the possible cause. Repair orders are returned via UPS Ground unless other arrangements are made. If you have further questions regarding repair procedures, contact Dart Controls, Inc. at 317-873-5211.

YOUR MOTOR SPEED CONTROL SOLUTIONS PROVIDER



125D SERIES
AC INPUT - VARIABLE DC OUTPUT
1/50 HP through 1.0 HP



250G SERIES
AC INPUT - VARIABLE DC OUTPUT
1/50 HP through 2.0 HP



65 SERIES
DC INPUT - VARIABLE DC OUTPUT
CURRENT RATINGS OF 20, 40, AND 60 AMPS



700/COMMUTROL SERIES
DC BRUSHLESS
5 & 20 Amp for
12,24,& 36VDC Inputs



MDP SERIES
PROGRAMMABLE
CLOSED LOOP DC
SPEED CONTROL



DM SERIES
FIELD PROGRAMMABLE
DIGITAL TACHOMETER

Dart Controls, Inc. is a designer, manufacturer, and marketer of analog and digital electronic variable speed drives, controls, and accessories for AC, DC, and DC brushless motor applications.

Shown above is just a sampling of the expanded line of Dart controls that feature the latest in electronic technology and engineering. Products are manufactured in the U.S.A. at our Zionsville (Indianapolis,

Indiana) production and headquarters facility - with over 2,000,000 variable speed units in the field.

In addition to the standard off-the-shelf products, you can select from a wide variety of options to customize controls for your specific application. For further information and application assistance, contact your local Dart sales representative, stocking distributor, or Dart Controls, Inc.

Dart Controls, Inc.

Manufacturer of high quality DC and AC motor speed controls and accessories since 1963.

P.O. Box 10
5000 W. 106th Street
Zionsville, Indiana 46077
Phone: (317) 873-5211
Fax: (317) 873-1105