

ASPII SERIES WIRING DIAGRAM - STANDARD LEADER ONLY

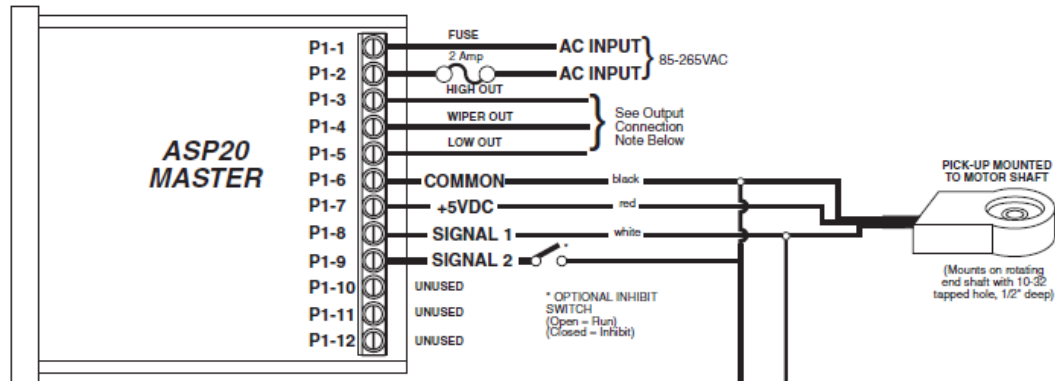

ASPII SERIES WIRING DIAGRAM - STANDARD FOLLOWER

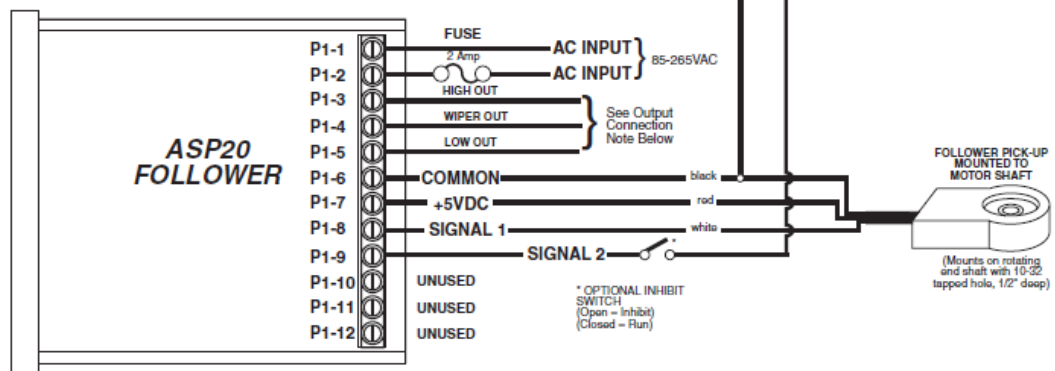

OUTPUT CONNECTION NOTE:

Connect to Speedpot input of the device being driven (P1-3 must be positive in respect to P1-5). If driven device has a positive supply, connect P1-3 to the Positive supply terminal (Pot High) and set Page 7 Item 11 to a value of zero. If driven device has a negative power supply, connect P1-3 to the Common terminal (Pot Low) and set Page 7 Item 11 to a value of 1.

HOOK-UP PROCEDURE:

- STEP 1: Connect the proper input voltage to P1-1 and P1-2. NOTE: Fusing should be added in the AC line to protect the control. A 2 amp fuse is recommended.
- STEP 2: Connect the PU-E as shown in hook-up diagram above.
- STEP 3: Wire the pot output of the ASP20 to the control being driven.
- STEP 4: You are now ready to apply power to your system.
- STEP 5: Turn IR Comp, Accel and Decel to full off position on driven control unit.

NOTE: SHIELDED CABLE IS RECOMMENDED FOR APPLICATIONS WHERE PICK-UP CORD LENGTH IS IN EXCESS OF 6 FEET. Connect the shield to the common terminal of the ASP20, leaving the shield at the pick-up end floating.

CAUTION: When master pick-up signal "A" is lost, the master ASP20 will run at full speed, while the follower ASP20 will go to zero speed. If the follower pick-up signal "B" is lost, the follower ASP20 will run at full speed and the master will be unaffected.