



VSI Series Voltage Signal Isolator*

The Dart VSI (voltage signal isolator) permits the user to control the output of a variable speed motor drive from any external grounded or ungrounded DC input signal. A single model accepts a wide range of input voltages (0-5 through 0-25VDC or 0-25 through 0-250VDC). The GAIN trimpot is used to adjust the output of the VSI to full on when a full speed signal is applied to its input terminals. The VSI incorporates Dart's patented feedback circuit, which virtually eliminates output changes due to the thermal drift

of logic components. The VSI is packaged in an aluminum chassis mount housing and contains an on-board power supply for its logic circuit. An electrical isolation rating of 2500Vrms is achieved by the use of an optically isolated IC package.

The Dart VSI can be used with virtually any motor speed control that has a speed reference circuit of +5 to +15VDC and an input impedance greater than 47K ohms. The output of the VSI is a filtered, pulse width modulated signal that is directly proportional to the input speed signal. The wide input range allows the VSI to follow signals as low as +0-5V logic levels and up to the 180 VDC levels present at the armature leads of a 180 VDC motor. By simply connecting the input terminals across the armature leads of a "master motor", you can use the VSI for master/follower operation. The addition of a scaling pot will provide for proportional follower operation.

* By adding a resistor across signal input, VSI can function as a Current Signal Isolator.

VSI SERIES SELECTION GUIDE

MODEL	SUPPLY VOLTAGE
VSI	120/240VAC 50/60 Hz.

DIMENSIONAL SPECIFICATIONS

WIDTH	LENGTH	DEPTH	WEIGHT
<i>English</i>			
3.630 in	4.250 in	1.650 in	9.8 oz
<i>Metric</i>			
9.220 cm	10.795 cm	4.191 cm	277.3 gm

VSI HOOK-UP CONFIGURATIONS

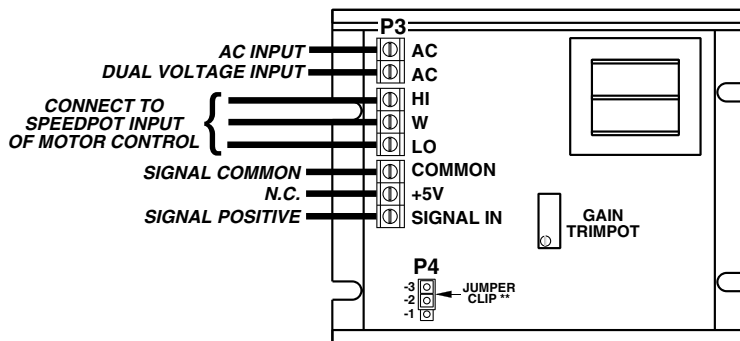

STANDARD HOOK-UP

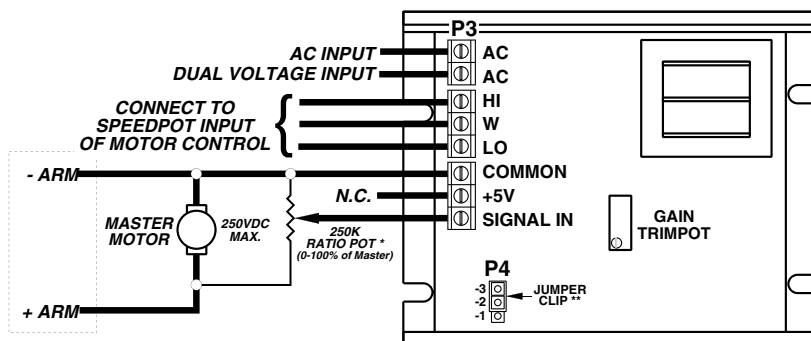

FOLLOWER MODE HOOK-UP

NOTES:

* If ratio of Master is NOT needed, delete the 250K pot and connect +Armature directly to Signal Input.

** Jumper clip is used to select input voltage range. When installed from P4-1 to P4-2, the range is 0-25VDC thru 0-250VDC; when installed from P4-2 to P4-3, range is 0-5VDC thru 0-25VDC.