



MD20P and MD30P cULus Recognized



MD30E cULus Listed

MDII Series Programmable Digital Closed Loop DC Speed Control with P-I-D and RS Communication

The MDII Series digital motor speed controls, employing an advanced 16-bit microprocessor, is designed for digital closed loop operation of up to 2 horsepower DC permanent magnet motors. This control features a true P-I-D algorithm, for extremely responsive and precise control over a wide variety of desired speeds and applications. **The MDII Series is designed as a companion or direct replacement control to the MD Series, while offering expanded performance features.**

Set or actual speed is displayed directly in RPM, FPM, PROCESS TIME, or other engineering units. Field programming permits customizing specific operating parameters.

The integrated RS485/RS422/RS232 serial interface port is perfect for monitoring or control using almost any computer or process controller. Units can even be attached in a Local Area Network, and can then be controlled and programmed either individually or all at once. Multiple programs allow the user to choose between a "menu" of up to six programmed configurations.

The MDII series is the ultimate answer for precise, responsive, cost-effective and flexible closed loop motor speed control.

COMMUNICATION FEATURES

- RS485; RS422; RS232 serial interface port for remote monitoring/control/programming allows the following:
 - Continuous output of actual shaft speed
 - Remote speed setting
 - Programming or listing of all field programmable parameters
 - Dartnet network allows multiple controls to be attached via one cable. Controls can be individually programmed or integrated.
 - Programmable communication baud rate - 300 to 9600 baud
- Network Follower mode allows widely remote controls to be followed together over single RS485 twisted pair wire or over existing network

STANDARD FEATURES

- Compact 1/8 or 1/4 DIN sturdy aluminum housing for panel mounting; or NEMA 4/12 enclosure
- Microprocessor based; utilizes powerful 16-bit Motorola C68HC11
- Field Programmable operating parameters
- Displays actual or desired speed directly in RPM, FPM, process time, or other engineering units
- P-I-D digital closed loop control; gains settable for optimum system performance; Fast settling time
- Accuracy $\pm 1/2$ RPM of set speed
- Master/Follower operation
- Variety of pick-up inputs; Hall-Effect, Photoelectric, or any TTL; control accepts up to 1.2 million pulses/min. max
- Non-volatile memory retains speed setting and all field programmable parameters
- Internal A/D interface permits using potentiometer, 4 to 20mA or 0 to +5 VDC signal in lieu of digital pick-up signal or to control target speed, current program or frequency generator output
- Inhibit circuit permits start and stop without breaking AC lines; pre-selecting speed, or simultaneous start-up of multiple control units
- Up/down pushbuttons for set points - slow-fast sweep; front panel lockout prevents accidental setting changes
- Self-contained power supply for transducer (+5V, 25mA)
- Transient voltage protection
- Exclusive user assignable outputs - to drive relays, alarms, etc. Can be activated by any combination of conditions; upper speed limit exceeded, etc.
- Independent frequency generator allows units to produce own leader frequency.
- European style terminal strip
- G.E. Lexan™ membrane seals faceplate from environment
- Multi-mode of operation allows multiple constants, settings, and upper/lower limits. Up to six different configurations can be selected from the front panel via the up/down pushbutton switches

PROGRAMMING FEATURES

- All programming from front panel "Menu Driven"
- User selectable "programming protect" prevents unauthorized access
- LED function indicators
- Programmable parameters include:
 - Lower/upper limits for speed setting
 - Accel/decel 0 to 30 seconds for 0-1000 RPM change
 - Pick-up pulses per revolution
 - P-I-D gain settings
 - Constants to allow display in desired user engineering units - rate or time
 - Decimal point or colon
 - "Stall detector" time-out for annunciation and shutdown
 - Multiple programs permit up to six different desired set-ups to be programmed
 - Selectable display blanking point
 - Operation mode (master rate, master time, standard follower, Network Follower)
 - Unit address for multiple control networking
 - Selectable serial communication rate
 - Front panel lockout for speed setting and/or program changes
 - Numerous other features

MDII SERIES SELECTION GUIDE

MODEL NUMBER	MAX. DC AMPS	MAX H.P.	INPUT	OUTPUT
MD20P	5	1/2	120 VAC	0-90 VDC
	5	1	240 VAC	0-180 VDC
MD30P	10	1	120 VAC	0-90 VDC
	10	2	240 VAC	0-180 VDC
MD30E	10	1	120 VAC	0-90 VDC
	10	2	240 VAC	0-180 VDC

- All models accept 85-265 VAC Single Phase Input.
- Peak motor output voltage is equal to peak AC input voltage.
- Requires Dart PU-E or other suitable pick-up.
 - Sensor must have minimum output current of 10 mA.
 - Drive includes supply for external sensor of 5VDC @25 mA max.
 - Shipped set for 0-2400 RPM with one pulse per revolution.

OPTION DESCRIPTION

OPTION	SUFFIX
Auto-Off-Manual control for 4-20mA or 0-5 VDC analog signal input (MD30E only)	-7
Magnetic pick-up input board	-3
Blank Lexan (MD20P, MD30P)	-9
Pluggable terminal strip	-P

WIRING DIAGRAM - MASTER

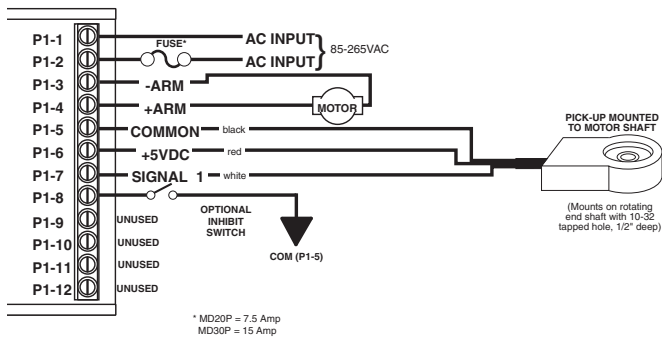

OPERATING SPECIFICATIONS

Temperature	-10° to +45° C.
AC Input Voltage	85-265 VAC
Input Frequency	50/60 Hz.
Overload Capacity	200% for 1 minute
Transducer Signal Input	0-5 to 0-25 VDC square wave

WIRING DIAGRAM-MASTER/FOLLOWER

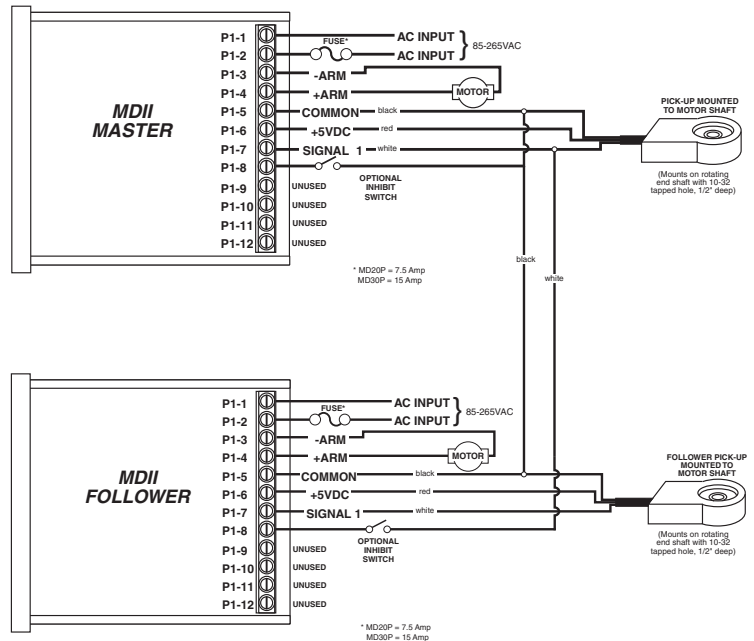

* MD30E uses a 15 Amp fuse and internally mounted on-off switch. No external fusing or switch needed.

DIMENSIONAL SPECIFICATIONS

MODEL	WIDTH	HEIGHT	DEPTH
<i>MD20P inches (millimeters)</i>			
Housing	3.620 (91.95)	1.656 (42.06)	4.625 (117.47)
Lens	4.539 (115.29)	2.289 (58.13)	0.375 (9.52)
<i>MD30P inches (millimeters)</i>			
Housing	3.620 (91.95)	3.497 (88.82)	4.625 (117.47)
Lens	4.539 (115.29)	4.179 (106.15)	0.375 (9.52)

MOUNTING SPECIFICATIONS - MD30E



MOUNTING SPECIFICATIONS - MD20P / MD30P

