

125 Series Variable Speed DC Control

125DV-C



Speed Potentiometer
Kit Included

cULus
cULus Recognized

CE

The 125 Series is a compact, cost efficient, reliable control for PM, shunt wound, and universal motors that incorporates up-to-date design and engineering into a compact package.

Installation and field adjustments are facilitated using a barrier type terminal strip and large, easily adjusted trimpots. Adjustable horsepower range: 120 VAC; 1/50–1/8 and 1/8–1/2; 240 VAC; 1/25–1/4 and 1/4–1.

The 123D-C model operates on a low input voltage of 24/36 VAC with an output of 150mA–5.5 ADC

Standard features include an inhibit circuit for start-stop operation and 1% speed regulation over a 50:1 speed range. Dual voltage 120/240 VAC or 24/36 VAC models are available.

Long life and quality are assured by 100% full load testing. The 125 Series is ideal for applications such as: office machinery, conveyors, office packaging equipment, printers, process equipment, centrifuges, and exercise equipment.

125 SERIES STANDARD FEATURES

- Dual Voltage 120/240 VAC or 24/36 VAC, 50/60Hz
- Adjustable horsepower settings
- Barrier terminal strip
- Full wave bridge supply
- 1% speed regulation with armature voltage feedback; ±1/2% with tach feedback
- Adjustable Minimum speed (0–30% of max)
- Adjustable Maximum speed (60–110% of base)
- Adjustable IR Compensation
- Adjustable Current Limit
- Fixed Acceleration (0.5 sec.)
- Line voltage compensation
- 5K ohm speed potentiometer with 8" leads, dial & knob included
- 50:1 speed range
- Overload capacity: 200% for one minute
- Transient voltage protection
- Voltage following mode or DC tachometer follower by supplying ungrounded analog input signal (0–12 VDC)
- DC tachometer feedback (6V at base speed)
- Inhibit circuit—permits start & stop without breaking AC lines
- Shunt field supply provided (1 Amp max; 100V for 120 VAC; 200V for 240 VAC input)

125 SERIES SELECTION GUIDE

H.P. RANGE	MODEL	INPUT	OUTPUT
150mA - 5.5ADC	123D-C	24/36 VAC	0-20/30 VDC
1/50 - 1/8 } 1/25 - 1/4 }	125D-12C	120 VAC	0-90 VDC
		240 VAC	0-180 VDC
1/8 - 1/2* } 1/4 - 1.0* }	125DV-C	120 VAC	0-90 VDC
		240 VAC	0-180 VDC

* With suitable external heatsink. UL rating for output amps can be increased from 5.5 amps DC to 10.0 amps DC.

Horsepower settings are adjustable - see installation manual. Control is tested and calibrated for maximum horsepower in its category.

OPERATING CONDITIONS

Temperature.....-10° to +45° C.
 AC Input Voltage±10% Rated Line Voltage
 Input Frequency 50/60 Hz.

ELECTRICAL SPECIFICATIONS AC INPUT 50/60 Hz

120 VAC Single Phase Input, 0-90 VDC Output

H.P.	MAX. AC AMPS	KVA	MAX. ARM* AMPS DC
1/50	0.5	0.06	0.4
1/20	1.0	0.12	0.8
1/8	2.0	0.24	1.6
1/4	3.5	0.42	2.7
1/3	4.4	0.53	3.4
1/2	6.5	0.78	5.0

240 VAC Single Phase Input, 0-180 VDC Output

H.P.	MAX. AC AMPS	KVA	MAX. ARM* AMPS DC
1/4	1.8	0.42	1.4
1/3	2.2	0.53	1.7
1/2	3.3	0.78	2.5
3/4	4.8	1.15	3.7
1	6.5	1.56	5.0

* Minimum Armature Amps: 150mA DC

DIMENSIONAL SPECIFICATIONS

MODEL	WIDTH	HEIGHT	DEPTH	WEIGHT
<i>English (inches)</i>				
Chassis	3.63	4.25	1.30	8 oz.
<i>Metric (centimeters)</i>				
Chassis	9.20	10.80	3.30	227 gm.

ADJUSTMENTS AND HOOK-UP

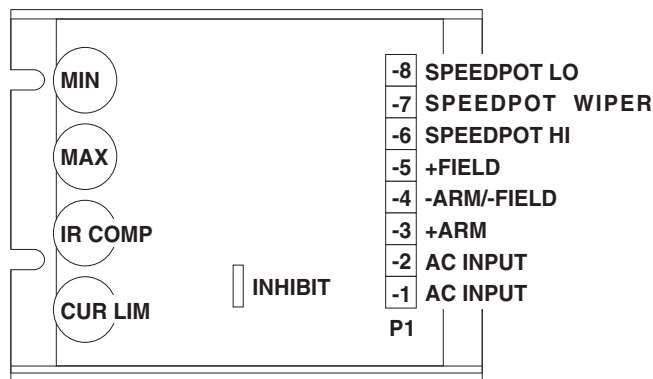

POPULAR OPTIONS

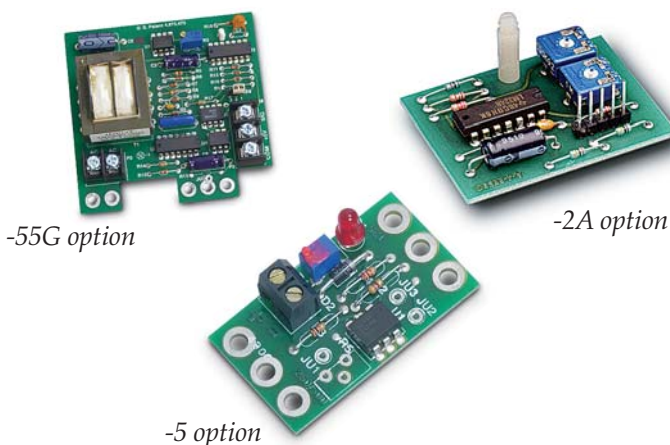

OPTION DESCRIPTION

OPTION	SUFFIX
Electronic speed control interlock - when AC power to control is applied, prevents motor from starting until speedpot is first rotated to the zero position, then CW. Also, should AC power be interrupted then restored, prevents automatic restart. (Patent # 4,888,813).....	-1*
Independently adjustable linear accel and decel (0.5 - 8.0 seconds).....	-2A*
4-20mA isolated signal follower.....	-5*
-5 option with Auto/Manual switch.....	-7*
Acceleration time (approx. 4 seconds).....	-15B
Acceleration time (approx. 6 seconds).....	-K
Forward-Off-Reverse manual switch (center blocked, no Dynamic Brake).....	-29B*
Isolated voltage follower (120/240 VAC input)—controls speed from any external grounded or ungrounded signal: 0-5 VDC thru 0-250 VDC adjustable.....	-55G*
-55G option with Auto-Manual function.....	-56G*
Auxiliary heatsink (7" long x 6.25" wide x 1.375" deep).....	-HS(125)*

Other options are available, please consult factory for your requirement.

* Field installable