

900AC CONTROL SERIES

DART

CONTROLS

Instruction Manual

AC Inverter

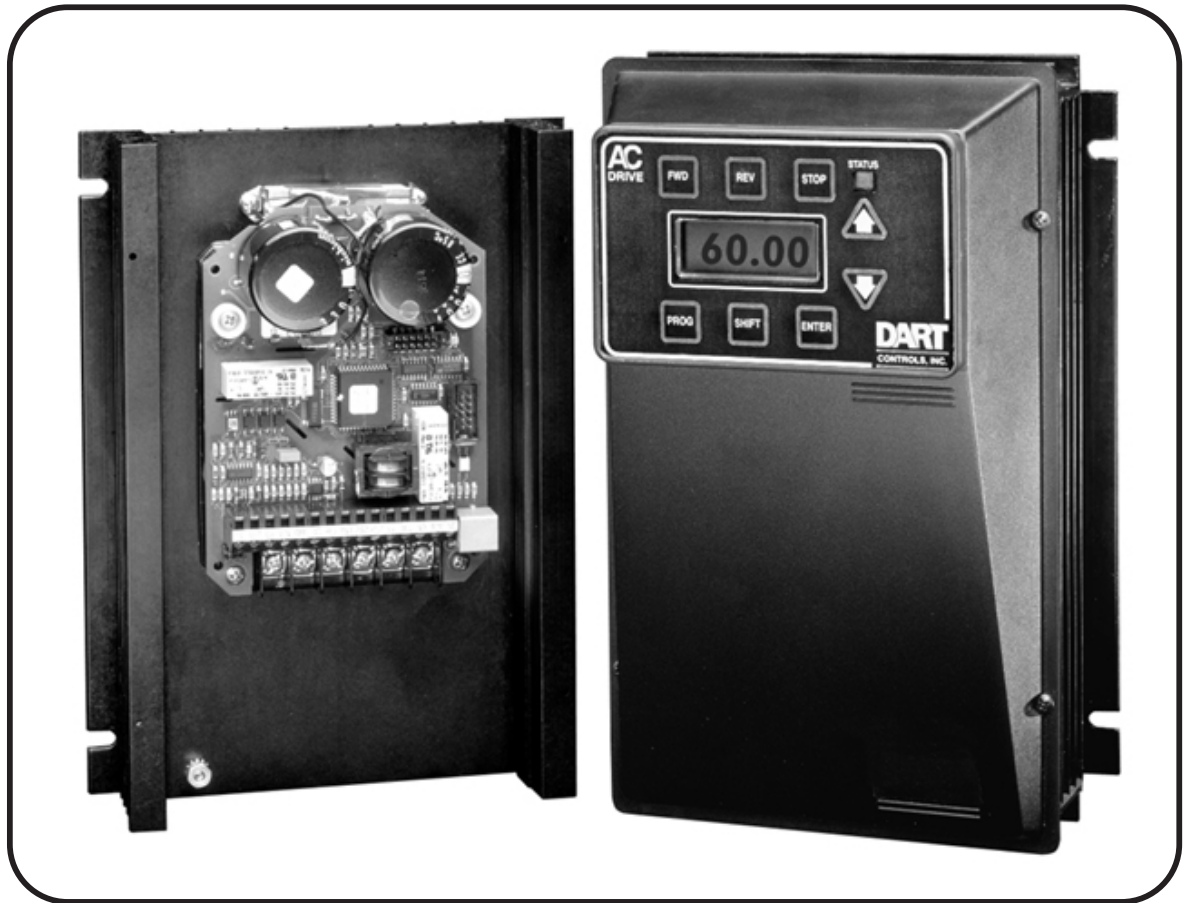

**P.O. Box 10
5000 W. 106th Street
Zionsville, Indiana 46077**

**Phone (317) 873-5211
Fax (317) 873-1105
www.dartcontrols.com**

TABLE OF CONTENTS

CONTENT HEADING	Page
0.1 Warranty	2
SECTION 1 - GENERAL INFORMATION	
1.1 Preface	3
1.2 Inspection	3
1.3 General Drive Specifications	3-4
1.4 Protection Features	4
SECTION 2 - INSTALLATION AND ENCLOSURE DIMENSIONS	
2.1 General Rules for Installation	4
2.2 Explosion Proof Applications	4
2.3 Line Starting	4
2.4 Dimensional Data	5
2.5 Input AC Line Requirements	6
2.6 AC Line Protection	6
2.7 Wiring Practices	7
2.8 Reducing Current Surges and Voltage Transients	7
2.9 Function and Use of Terminals	8
2.10 J22 Option Connector	8
2.11 Input Terminal Usage	8-9
2.12 J19 Configuration	9-10
SECTION 3 - GETTING STARTED	
3.1 General Information	10
3.2 Digital Keypad	10
3.3 Keypad Operation	10
3.4 Operation Mode	11
3.5 Program Mode	11
3.6 Status Indicator	11-12
3.7 Description of Displays	12
3.8 Parameter Access	13
3.9 Display Scroll Rate	13
3.10 Restoring Factory Settings	13
3.11 Quick Start for Chassis Models without Keypad	13
3.12 Quick Start for Enclosed Models	13-14
SECTION 4 - PARAMETER DESCRIPTIONS AND PROGRAMMING	
4.1 Programming	14
4.2 Parameter Descriptions	14-21
SECTION 5 - CONNECTION DIAGRAMS	
5.1 AC Line and Motor Connections	22
5.2 Two-Wire Run/Stop Connections	22
5.3 Three-Wire Run/Stop Connections	23
5.4 Analog Speed Input Connections	23
5.5 MOL Terminal Connections	23
5.6 Optional Connections	24
SECTION 6 - TROUBLESHOOTING	
6.1 Special Indications	25
6.2 Fault Trip Indications	25
6.3 Resetting a Fault	25
6.4 Fault Codes	26
6.5 Troubleshooting	27
900AC SERIES MICRO-INVERTER - PARAMETER CODE SUMMARY	27-28
REPAIR PROCEDURE & PRODUCT LINE	BACK COVER

WARNING

IMPROPER INSTALLATION OR OPERATION OF THIS CONTROL MAY CAUSE INJURY TO PERSONNEL OR CONTROL FAILURE. THE CONTROL MUST BE INSTALLED AND GROUNDED IN ACCORDANCE WITH LOCAL, STATE, AND NATIONAL SAFETY CODES.

WARRANTY

Dart Controls, Inc. (DCI) warrants its products to be free from defects in material or workmanship. The exclusive remedy for this warranty is DCI factory replacement of any part or parts of such product which shall within 12 months after delivery to the purchaser be returned to DCI factory with all transportation charges prepaid and which DCI determines to its satisfaction to be defective. This warranty shall not extend to defects in assembly by other than DCI or to any article which has been repaired or altered by other than DCI or to any article which DCI determines has been subjected to improper use. DCI assumes no responsibility for the design characteristics of any unit or its operation in any circuit or assembly. This warranty is in lieu of all other warranties, express or implied; all other liabilities or obligations on the part of DCI, including consequential damages, are hereby expressly excluded.

CAREFULLY CHECK THE CONTROL FOR SHIPPING DAMAGE. REPORT ANY DAMAGE TO THE CARRIER IMMEDIATELY. DO NOT ATTEMPT TO OPERATE THE DRIVE IF VISIBLE DAMAGE IS EVIDENT TO EITHER THE CIRCUIT OR TO THE ELECTRONIC COMPONENTS.

ALL INFORMATION CONTAINED IN THIS MANUAL IS INTENDED TO BE CORRECT, HOWEVER INFORMATION AND DATA IN THIS MANUAL ARE SUBJECT TO CHANGE WITHOUT NOTICE. DCI MAKES NO WARRANTY OF ANY KIND WITH REGARD TO THIS INFORMATION OR DATA. FURTHER, DCI IS NOT RESPONSIBLE FOR ANY OMISSIONS OR ERRORS OR CONSEQUENTIAL DAMAGE CAUSED BY THE USER OF THE PRODUCT. DCI RESERVES THE RIGHT TO MAKE MANUFACTURING CHANGES WHICH MAY NOT BE INCLUDED IN THIS MANUAL.

WARNING

MAKE CERTAIN THAT THE POWER SUPPLY IS DISCONNECTED BEFORE ATTEMPTING TO SERVICE OR REMOVE ANY COMPONENTS !!! IF THE POWER DISCONNECT POINT IS OUT OF SIGHT, LOCK IT IN DISCONNECTED POSITION AND TAG TO PREVENT UNEXPECTED APPLICATION OF POWER.

ONLY A QUALIFIED ELECTRICIAN OR SERVICEMAN SHOULD PERFORM ANY ELECTRICAL TROUBLESHOOTING OR MAINTENANCE.

AT NO TIME SHOULD CIRCUIT CONTINUITY BE CHECKED BY SHORTING TERMINALS WITH A SCREWDRIVER OR OTHER METAL DEVICE.

SECTION 1 - GENERAL INFORMATION

1.1 Preface

This manual contains the specifications, installation instructions, description of operation, and trouble-shooting procedures for the 900AC Series. Before installing the drive, read this manual carefully to ensure correct installation and maximum performance.

1.2 Inspection

A. Upon receipt, unpack and carefully inspect for any damage sustained in transit (depression in the enclosure, damage to parts, missing parts). If damage is apparent, the shipping agent should be notified.

B. Remove the terminal access cover (see Section 2.9C), if supplied, and inspect for any apparent damage or foreign objects.

C. Read the technical data label and ensure that the correct horsepower and input voltage for the application has been purchased.

D. If the inverter is to be stored for a long period of time, repack and store in a clean, dry place, free from direct sunlight or corrosive fumes, and in a location where the ambient temperature will not be less than $-20\frac{1}{2}^{\circ}\text{C}$ ($-4\frac{1}{2}^{\circ}\text{F}$) or more than $+60\frac{1}{2}^{\circ}\text{C}$ ($+140\frac{1}{2}^{\circ}\text{F}$).

HP (MAX)	AC INPUT VOLTAGE	MODEL TYPE		AC OUPUT VOLTAGE	MAX INPUT AMPS	MAX OUTPUT AMPS	KW
		ENCLOSED	CHASSIS				
1/2	115V, 1F	910AC50E	910AC50C	3.5 - 230VAC	4.5	2.2	0.37
1/3	208-230V, 1F	920AC50E	920AC50C	3.5 - 230VAC	2.2	1.8	0.25
1/2	208-230V, 3F			3.5 - 230VAC	1.8	2.2 ¹	0.37
1.5	208-230V, 1F	920AC200E	920AC200C	3.5 - 230VAC	8.1	5.7	1.10
2	208-230V, 3F			3.5 - 230VAC	7.5	7.5 ¹	1.50
1	460V, 3F	940AC100E	940AC100C	7.0 - 460VAC	2.3	2.2	0.75
2	460V, 3F	940AC200E	940AC200C	7.0 - 460VAC	5.1	4.1 ¹	1.50

1-This value equals 1.1 x 03-IRAT (see Section 4.2).

Table 1.1

1.3 General Drive Specifications

Overload capacity 150% for 60 seconds
 Starting torque greater than 100%
 Input frequency 50/60 Hz
 Phase imbalance (3Φ only) ± 2%
 Operating temperature 0° to +40°C (NEMA4/12 models); 0° to +50°C (chassis model)
 Humidity 90% RH or less, non-condensing
 Vibration 0.6 G maximum
 Elevation 1000 meters (3,300 feet) above sea level w/o derating
 Frequency range 0.1 to 400 Hz programmable in 0.05 Hz increments (0.1 Hz above 99.95 Hz)
 Control system voltage vector PWM
 Frequency command selections 0-5 VDC, 0-10 VDC, 0-20 mA, 4-20 mA, direct or inverted;
 digital keypad; program memory unit, remote keypad unit
 Frequency resolution 0.05 Hz or 0.1% of maximum frequency
 V/Hz ratio 0.24 - 8.85 (230 VAC models)
 Acceleration and deceleration range programmable 0.1 to 600 seconds to maximum frequency (2 each)
 Maximum/minimum frequency Separately programmable to 400 Hz
 Preset speeds up to 8 available; programmable to maximum frequency
 Torque limit four quadrant, programmable

1.3 General Drive Specifications (continued)

Dynamic braking	up to 60% for 6 seconds with standard DB resistor
PWM frequency	9.2 kHz
Operating controls	keypad, terminal strip, remote keypad unit, program memory unit
LED indicators	red and green for operation and fault annunciation (see Section 3.6)
Keypad display	6 digit, backlit LCD with special annunciators and unit symbol
Auxiliary relay	programmed as fault - programmable to signal one of ten conditions
Programming levels	level 1 - operator; level 2 - engineer
Input control terminals	15; multifunctional; pull-up or pull-down logic

1.4 Protection Features

Ground fault	checked at start-up, optional full time
Short circuit	protected from damage
Motor overload	programmable inverse time overload trip
Overvoltage	protected from damage (500mS ride-through)
Undervoltage	protected from damage (200mS ride-through, load dependent)
Motor overload input terminal	programmable for N.C. or N.O. contacts
Torque limit	full time four quadrant "trip-free" operation
Over temperature	protected from damage, warning display

SECTION 2 - INSTALLATION & ENCLOSURE DIMENSIONS

2.1 General Rules for Installation

Improper installation of the inverter will greatly affect its life. Be sure to observe the following points when selecting a mounting location.

A. Do not install the inverter in a place subjected to high temperature, high humidity, or excessive vibration (see Section 1.3 for temperature, humidity and maximum vibration limits).

B. Mount the drive vertically and do not restrict the air flow to the heat-sink fins.

C. The 900AC series generates heat. Allow sufficient space around the unit, as shown in Figure 2.1.

D. When mounting a drive in another enclosure (with the fins inside the enclosure), consult manufacturer for enclosure sizing and mounting instructions.

E. Do not mount the 900AC series above heat generating equipment, or in direct sunlight.

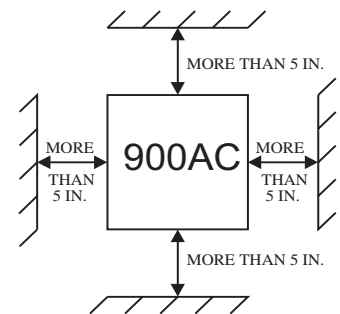

Figure 2.1

2.2 Explosion Proof Applications

Explosion proof motors that are not rated for inverter use lose their certification when used for variable speed. Due to the many areas of liability that may be encountered when dealing with these applications, the following statement of Company Policy applies:

“Dart Controls Incorporated AC Inverter products are sold with no warranty of fitness for particular purpose or warranty of suitability for use with explosion proof motors. Dart Controls accepts no responsibility for any direct, incidental or consequential loss, cost or damage that may arise through the use of its AC inverter products in these applications. The purchaser expressly agrees to assume all risk of any loss, cost or damage that may arise from such application. Dart Controls engineering department will not knowingly approve applications involving explosion proof motors.”

2.3 Line Starting

The 900AC series is designed to provide controlled starting and stopping of AC motors by use of the keypad or external contacts connected to the control terminal strip. The drive may also be started by using a maintained contact (2-wire operation) and applying AC power to terminals L1, L2, and L3. To prevent accidental starting of the motor, the inverter has line-start-lockout as a standard feature. This provision can be defeated by programming 82-START (see Section 4.2).

THE INVERTER MAY BE STARTED ONCE EVERY TWO (2) MINUTES IN THE LINE START MODE.

2.4 Dimensional Data

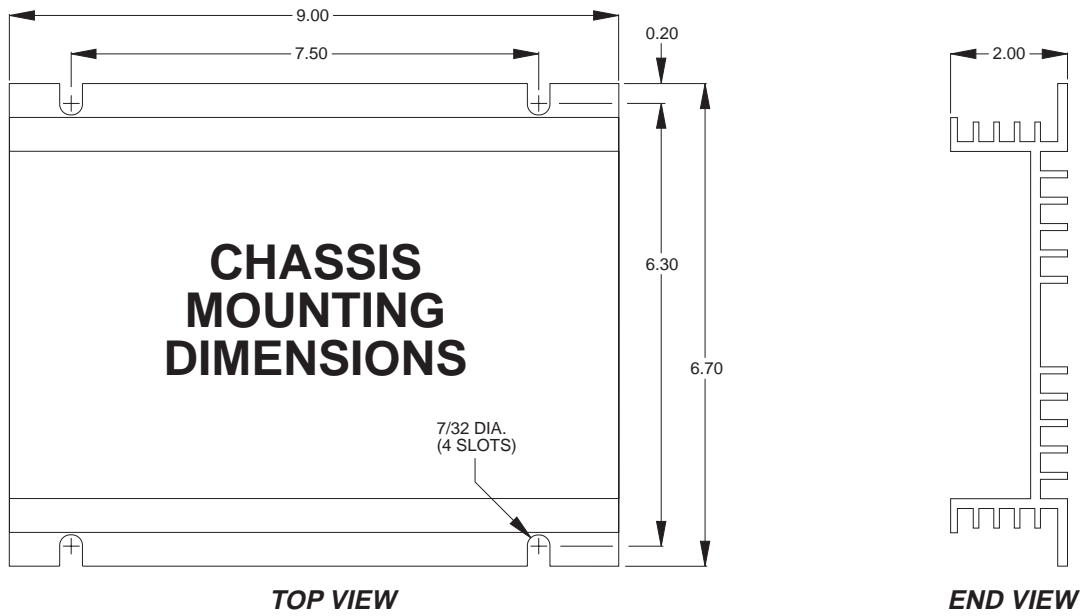

Figure 2.2 - Used with 910AC50C, 920AC50C, and 920AC100C controls.

Overall dimensions for models 910AC100C and 920AC200C are 3.15" high x 6.70" wide x 9.00" long.

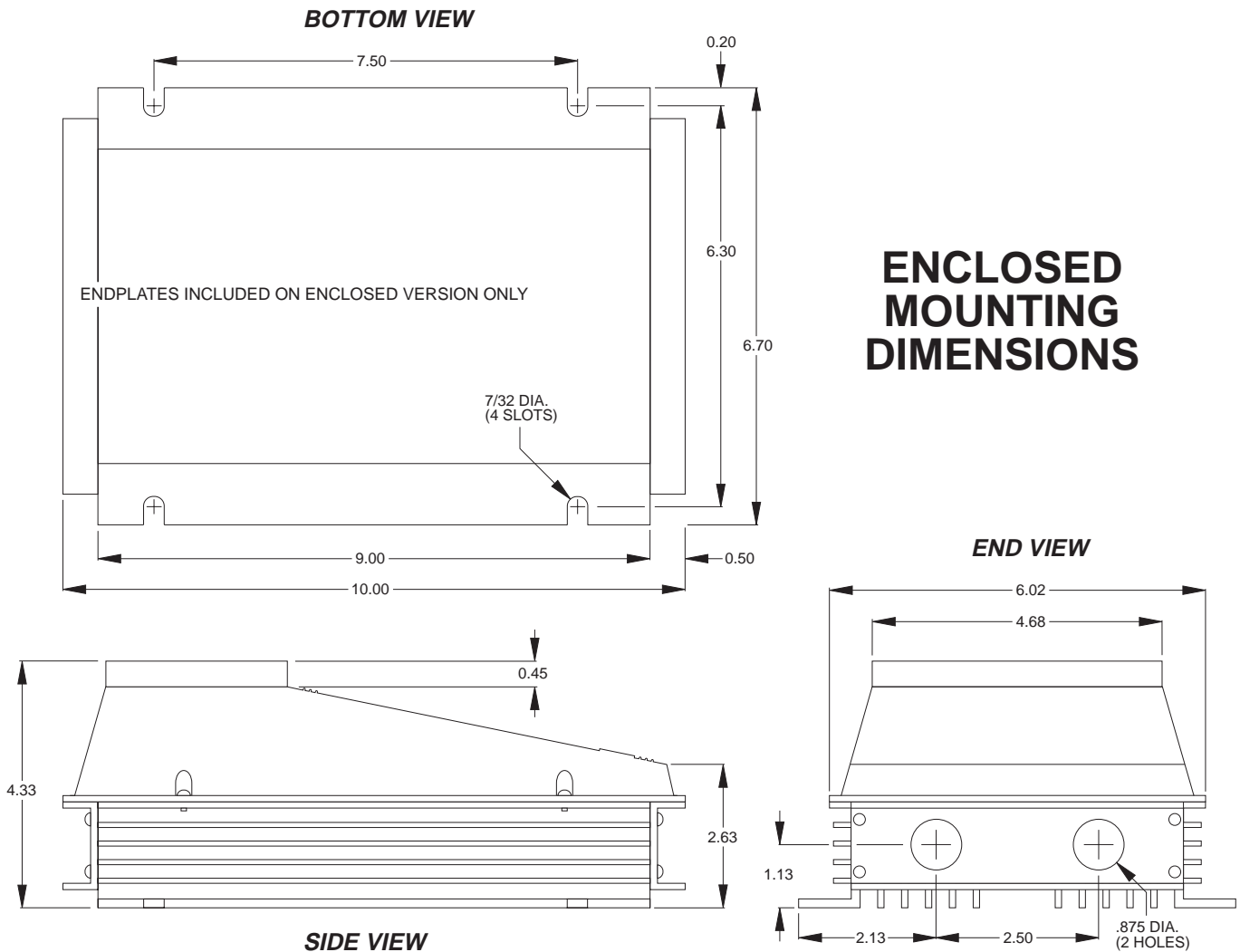

Figure 2.3 - Used with 910AC50E, 920AC50E, and 920AC100E controls.

Overall dimensions for models 910AC100E and 920AC200E are 5.48" high x 6.70" wide x 10.00" long.

WARNING
Hazard of electrical shock. Disconnect power before working on this drive.
Caution: Dangerous voltages exist until the STATUS indicator is off.

2.5 Input AC Line Requirements

The allowable AC line voltage fluctuation is specified in Table 1.1. A supply voltage above or below these limits will cause the inverter to trip out with either an overvoltage or an undervoltage fault.

Note: If the source of the AC power to the 900AC series is greater than ten times the kVA rating shown in Table 2.1, an isolation transformer or line inductors are recommended. Consult the factory for help in sizing the inductors.

INPUT POWER TRANSFORMER RATINGS			
Rated Horsepower	0.5	1.0	2.0
Minimum kVA Rating	1.5	3.0	5.0

Table 2.1

NOTE: Caution must be exercised when applying 900AC series controls on low line conditions. For example, an 920AC series controller will operate properly on a 208 VAC line; however, the maximum output voltage will be limited to 208 VAC. If the motor is rated for 230 VAC line voltage, higher motor currents and increased heating will result. **Insure that the voltage rating of the motor matches the applied line voltage.** If other than 60 Hz output is desired, proper volts/hertz can be programmed into the inverter by the 53-FKNEE and 32-FMAX parameters. If you are unsure about this feature, consult the factory.

Phase voltage imbalance of the input AC source can cause unbalanced currents and excessive heat in the input rectifier diodes and in the DC bus capacitors of the inverter. Phase imbalance can also be damaging to motors running directly across the line.

CAUTION:

NEVER USE POWER-FACTOR CORRECTION CAPACITORS ON THE 900AC SERIES MOTOR TERMINALS M1, M2, AND M3, OR DAMAGE TO THE SEMICONDUCTORS WILL RESULT.

A. Single Phase Operation

The 900AC series controllers are designed for both three phase and single phase input power. If operating with single phase power, use line terminals **L1** and **L2**. The output of the drive will always be three phase. See Table 1.1* for applicable derating when using single phase input power and Section 5, Figure 5.1 for proper power connections. **Do not connect single-phase motors to the inverter output terminals M1, M2 or M3.**

2.6 AC Line Protection

The user must provide either a circuit breaker or a fused disconnect switch on the input AC line in accordance with all applicable electrical codes. The following rules should be used to select the correct size of the input line fuses or circuit breaker.

A. Sizing

The 900AC series motor control is able to withstand a 150% overload for 60 seconds. For applications with short intermittent loads over 100%, select a fuse or magnetic trip circuit breaker rated at 1.5 times the input current rating of the drive. For applications with repetitive load peaks above 100%, select 1.7 times the input current (see Section 1.2, Table 1.1 for input current ratings). Minimum voltage rating for the protection device should be 250 VAC.

B. Fuse Type

For maximum protection of the inverter, current limiting fuses should be used. These fuses should provide 200,000 ampere RMS interrupting capacity and low I²T values. Recommended fuses are Bussman FRN-R.

2.7 Wiring Practices

A. Power Wiring

Power wiring are those wires which are connected to terminals L1, L2, L3, M1, M2, and M3. Power wiring must be selected as follows:

1. Use only UL™ recognized wire.
2. Wire voltage rating must be a minimum of 300 V.
3. Wire gauge must be selected based on 125% of continuous output current rating of the drive. Wire gauge must be selected from wire tables for 60½C or 75½C insulation rating, and must be of copper construction. Refer to Table 1.1 for continuous output ratings.
4. Grounding should be in accordance with NEC and the CEC.

CAUTION:

1. **Never connect input AC power to the motor output terminals M1, M2 and M3 or damage to the drive will result.**
2. **Power delivered from variable frequency drives contains high frequencies which may cause interference with other equipment. Control wiring should not be run in the same conduit or raceway with power or motor wiring.**

B. Control Wiring

This is wiring connected to the control terminal strip (15 terminals). It must be selected as follows:

1. Shielded wire is recommended to prevent electrical noise interference from causing improper operation or nuisance tripping. Connect the shield to terminal **CM** (control common) on the 900AC series control terminal strip only.
2. Use only UL™ recognized wire.
3. Wire voltage rating must be a minimum of 300 V. This is Class 1 wire.
4. Never run the control wiring in the same conduit or raceway with power wiring. See CAUTION above.

2.8 Reducing Current Surges and Voltage Transients

Inrush currents to the coils of magnetic contactors, relays and solenoids associated with, or in close proximity to the inverter can induce high current spikes in the power and control wiring causing faulty inverter operation. If this condition occurs, a snubber network, consisting of a series resistor and capacitor for AC loads, or a free-wheeling or flyback diode for DC loads, should be placed across the relay coil.

For magnetic contactors, relays and solenoids which are energized from a DC source, a free-wheeling diode should be used. The diode should be a high-speed, fast recovery type. Connect the diode across the coil with the cathode end toward the positive power source. The diode current and voltage should be selected by the following formula:

$$\text{Diode Current Rating (A)} \geq \frac{\text{Coil Capacity (VA)}}{\text{Rated Voltage of Coil (V)}}$$

$$\text{Diode Voltage Rating} \geq \text{Rated Voltage of Coil (V)} \times 2$$

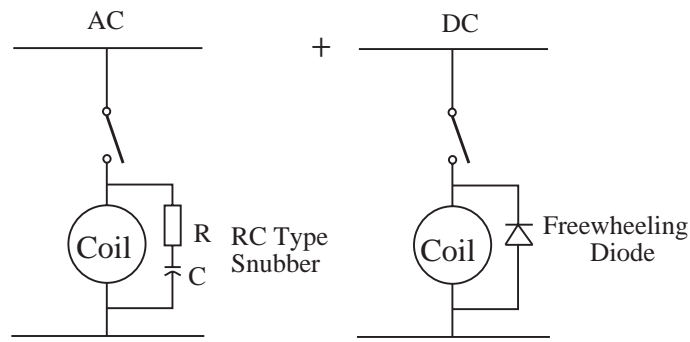

Figure 2.4

2.9 Function and Use of Terminals

Refer to Section 5 - Connection Diagrams for power and control wiring examples.

A. Power Circuit Terminals

The power terminals are located on the 900AC series power module, and are labeled **L1**, **L2**, and **L3** for incoming 3-phase AC line power, and **M1**, **M2**, and **M3** for the motor connections. The ground screw is green and is located on the heatsink chassis and must be connected to earth ground in accordance with the NEC.

B. Control Terminals

The control terminals are located on the bottom edge of the inverter's control board (see Section 2.11). These terminals are available for use with external devices.

NOTE: Control input signals must not exceed 24 VDC ± 20% potential to ground.

- Control terminal input impedance:
 - **VIN** terminal - 100 kΩ (0-5/10 VDC input)
 - **VIN** terminal - 250 Ω (0/4-20 mA input)
 - **FWD, REV, PS1, PS2, PS3, MOL**, - 4.5 kΩ

- Logic input levels:

LOGICTYPE	PULL-UP	PULL-DOWN
ACTIVE	10 - 24 VDC	0 - 3 VDC
INACTIVE	0 - 3 VDC	10 - 24 VDC

The input logic is compatible with either 12 or 24 VDC logic. **J19** selects active High or Low control inputs (see Section 2.12)

C. Cover Removal

To remove the cover, unscrew the four cover mounting screws and lift the cover away.

D. Cover Installation

To assure the environmental integrity of the NEMA 4/12 models, unused conduit fittings must be sealed. Also, the cover screws must be properly tightened. After all electrical connections are made, tighten all four (4) cover screws. Tighten alternate corners to assure even compression of the enclosure gasket.

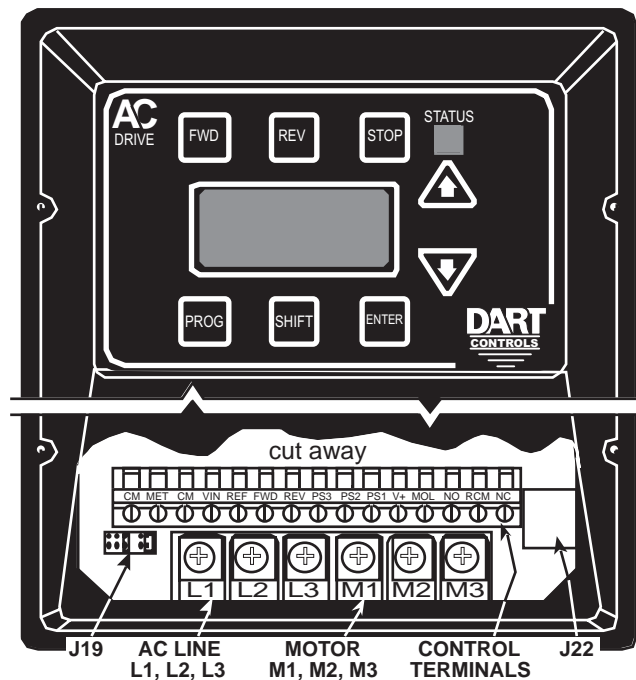

Figure 2.5

2.10 J22 Option Connector

Connector J22, is located on the right side of the 900AC Series micro-inverter. Keypad options interfaced through J22 may be mounted up to 300 feet from the drive.

2.11 Input Terminal Usage

The 900AC Series micro-inverter has a 15 position control terminal block (see Table 2.2 on following page). Some functions are defined by the setting of jumper **J19** (located below 15 position terminal strip), while others are defined by programming. Refer to Section 5 - Connection Diagrams and Figure 2.5 above.

DESCRIPTION OF TERMINALS				
CM	Circuit common, isolated from ground.			
MET	Analog meter output providing a 0 to 10 VDC (1 mA max.) signal proportional to output frequency, load, or current via setting of 71-METER. The output may be calibrated by programming 70-MCAL while running.			
VIN	Analog speed input, J19 jumper selectable for 0-5 VDC, 0-10 VDC or 0/4-20 mA DC. A 4 mA offset is programmed by 24-FSEL.			
REF	5.2 VDC reference voltage, 3 mA maximum load. USE ONLY FOR A FREQUENCY CONTROL POTENTIOMETER (5 kΩ Recommended).			
FWD	Digital input for Forward operation. May be programmed for maintained (standard) or momentary contacts by 21-MODE.			
REV	Digital input for Reverse operation. May be programmed for maintained (standard) or momentary contacts by 21-MODE.			
V+	Positive nominal 12 VDC voltage. Only for use with digital inputs (see Section 5). NO OTHER USE IS ALLOWED.			
MOL	Motor Overload Relay input. May be configured to generate a fault on opening or closing. May also be configured to command a coast-to-stop on opening or closing (see Section 4.2, 77-MOL).			
PS1 PS2 PS3	Digital inputs normally used for preset speed selection. Jumper J19 selects pull-up or pull-down logic (see Section 2.12). PS3 can define as a run-jog selector by 21-MODE or as the ART selector by 41-RSEL. Eight preset speeds are available if all three inputs are used, and four are available if PS3 is redefined via 21-MODE or 41-RSEL.			
	PS1	PS2	PS3	EFFECTIVE SPEED REFERENCE
	0	0	0	Basic speed setpoint (keypad or terminals)
	1	0	0	33-F2
	0	1	0	34-F3
	1	1	0	35-F4
	0	0	1	36-F5
	1	0	1	37-F6
	0	1	1	38-F7
	1	1	1	32-FMAX
PS1	0	0	N/A	Basic speed setpoint (keypad or terminals)
PS2	1	0	N/A	33-F2
	0	1	N/A	34-F3
	1	1	N/A	35-F4
NO	Normally open contact for the auxiliary relay. Will close when the relay is activated. Rating is 115 VAC at 1 Ampere.			
RCM	Auxiliary relay common terminal. Factory programmed as a fault relay but may be set to activate under one of ten conditions (see Section 4.2, 75-STR).			
NC	Normally closed contact for the auxiliary relay. Will open when the relay is activated. Rating is 115 VAC at 1 Ampere.			

Table 2.2

2.12 J19 Configuration

J19 is a pin-jumper selector located below the terminal block on the left-hand side of the control board. It has five (5) positions and two movable shorting jumpers. One jumper selects the analog speed reference used and the second jumper selects the active state (high or low) of the digital inputs. A pair of small needle nose pliers will prove useful for moving these jumpers. **REMOVE AC POWER AND WAIT FOR ALL INDICATORS TO GO OUT BEFORE CHANGING THIS JUMPER.**

(continued on following page)

Analog Reference Selection (24-FSEL selects direct or inverse operation)

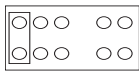

This configures the drive to accept an external 0-10 VDC speed reference signal. Input impedance is 100 k Ω .

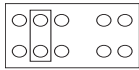

This configures the drive for either a 0-20 mA or a 4-20 mA input from an external source. 0 or 4 mA is selected by **24-FSEL**.

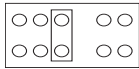

(DEFAULT SETTING) This configures the drive for an external 0-5 VDC signal, or a speed potentiometer powered from the REF terminal on the control terminal strip.

Digital Input Logic Selection

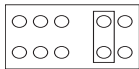

This configures the digital inputs for pull-down logic. That is, active when connected to terminal **CM**. Inputs are high, and are pulled low to activate.

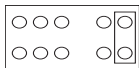

(DEFAULT SETTING) This configures the digital inputs for pull-up logic. That is, active when connected to terminal **V+**, or to an external power supply with it's common connected to **CM**. Inputs are low and require a positive voltage to activate them. 0 to 3 VDC is INACTIVE, 10 to 24 VDC is ACTIVE.

SECTION 3 - GETTING STARTED

3.1 General Information

* Some 900AC Series micro-inverters do not include a digital keypad as standard equipment. These models are programmed to operate via the control terminal strip. They may be reprogrammed using the optional keypad 900KP.

* Your 900AC Series micro-inverter is preprogrammed to run a standard 4-pole AC induction motor; in many cases no additional programming is required. Additional programming may be required for 2-pole or 6-pole motors.

* The advanced digital keypad controls all operations of the inverter. The eight input keys allow “Press and Run” operation of the motor and straight forward programming of the parameters. To simplify the programming further, the parameters are separated into two Program Levels:

LEVEL 1 Easily entered by pressing the **PROG** key at any time. Limits access to the most commonly used parameters for operator convenience.

LEVEL 2 Accesses all parameters including those in Level 1. Used when the more advanced features are needed. It is entered by pressing and holding the **SHIFT** key then pressing the **PROG** key.

Parameters may only be programmed when the drive is stopped, with the exception of 70-MCAL which may be programmed at any time (See Section 4.2).

3.2 Digital Keypad

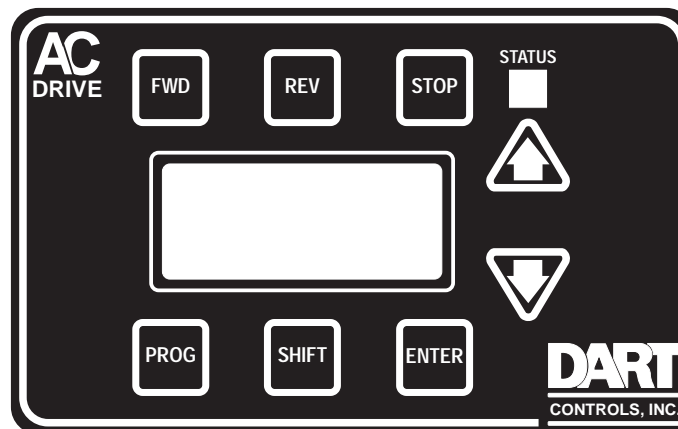

Figure 3.1

3.3 Keypad Operation

When 21-MODE is set to 0 or 10, start/stop and speed commands are accepted from the keypad. The keys are used to operate the inverter as described in Section 3.4.

3.4 Operation Mode (RUN and STOP modes)

KEY	FUNCTION
FWD	Initiates forward run when pressed momentarily. If the drive is running in reverse when FWD is pressed, it will decelerate to zero speed, change direction, and accelerate to the set speed.
REV	Initiates reverse run when pressed momentarily. If the drive is running in forward when REV is pressed, it will decelerate to zero speed, change direction, and accelerate to the set speed.
STOP	Causes a Ramp-To-Stop when pressed. Programmable to Coast-To-Stop by 41-RSEL.
UP	In the Stop mode, pressing this key increases the desired running speed of the drive. In the Run mode, pressing this key increases the actual running speed of the drive. Setting resolution is 0.05 Hz up to 99.95 Hz and 0.1 Hz above this frequency. The display will scroll at an increased rate after holding the key for 5 seconds. Pressing SHIFT while holding the UP arrow bypasses the delay.
DOWN	In the Stop mode, pressing this key decreases the desired running speed of the drive. In the Run mode, pressing this key decreases the actual running speed of the drive. Setting resolution is 0.05 Hz up to 99.95 Hz and 0.1 Hz above this frequency. The display will scroll at an increased rate after holding the key for 5 seconds. Pressing SHIFT while holding the DOWN arrow bypasses the delay.
ENTER	In the Stop or Run modes, pressing this key will store the selected frequency as the initial operating frequency when the inverter is powered up. The frequency is maintained until another frequency is entered.
PROG	In Run mode, pressing this key will access Level 1 Parameters for Viewing only. Holding SHIFT and then pressing PROG will access Level 2. Any attempt to program (other than 70-MCAL) will result in a display that shows “- - - -”. In Stop mode, programming is allowed in both Level 1 and Level 2 (see Section 3.5).

Table 3.1

3.5 Program Mode

KEY	FUNCTION
PROG	When in Stop mode, pressing this key will enter the Program mode at Level 1. Pressing the key at any time while in the Program mode will return the unit to the Operation mode. Pressing and holding SHIFT while pressing PROG will access Level 2. If an access code has been invoked, it must be entered to change data code (see Section 4.2, 87-ACODE).
UP	In the Program mode, pressing this key will move forward through the successive parameters. If the PRG indicator is flashing it increases the data code. The ENTER key must be pressed to store the data code.
DOWN	In the Program mode, pressing this key will move backward through the successive parameter addresses. If the PRG indicator is flashing it decreases the data code. The ENTER key must be pressed to store the data code.
	NOTE: If the PRG indicator is flashing, momentarily pressing and releasing both the UP and DOWN arrows simultaneously will return the data code to factory defaults. Press ENTER to store the new code.
SHIFT	Pressing this key while a parameter is displayed will allow that parameter to have its data code changed by use of the UP and DOWN arrow keys.
ENTER	This key must be pressed after the data code has been changed to store the new code. The display will show STORed for one second indicating the data code has been entered into memory.

Table 3.2

3.6 Status Indicator

The STATUS indicator consists of two LEDs, one green and one red located in the upper right corner of the control board. They are visible through a lens in the upper right corner of the keypad on the NEMA 4/12 models. The following table defines the STATUS indicator state for the various operating conditions of the inverter.

(continued on following page)

(Status indicator continued)

STATUS INDICATOR		OPERATING CONDITION
COLOR	DURATION	
Green & Red	Continuous	Power on, restart (2 seconds)
Red	Continuous	Stop, running in torque limit
Green	Continuous	Run
Green & Red	Flashing	Running in and out of torque limit
Green	Flashing	Running in and out of an overvoltage or undervoltage condition
Red	Flashing	Drive faulted, emergency stop, line start lockout or low voltage

Table 3.3

3.7 Description of Displays

The custom, backlit, LCD display provides information on drive operation and programming. The four large 7-segment displays show drive output and programming data. The two smaller digits are used to indicate parameter numbers in the Program mode. Special symbols and displays provide further clarification of drive operation. Figure 3.2 shows all segments displayed. In normal operation only those segments that are active are displayed.



Figure 3.2

Table 3.4 lists the special annunciators and their meaning.

SYMBOL	DESCRIPTION
FWD	Forward direction commanded
REV	Reverse direction commanded
PRG	Program mode selected (continuous) Data code may be changed (flashing)
SET	Drive is stopped, or is having the running frequency set
OV	Drive is in an overvoltage condition
UV	Drive is in an undervoltage condition
LIM	Drive is running in torque limit
OC	Drive is in (flashing) or has tripped (continuous) due to an overcurrent condition
TEMP	Drive is near (flashing) or has tripped (continuous) due to an over temperature condition
DB	The standard Dynamic Brake circuit is active
rpm	Revolutions per minute indication
Hz	Frequency in Hertz
h	Time in hours
s	Time in seconds
A	Output current indication in Amperes
V	Output voltage indication in Volts
%	Display is in percent of units
C	Degrees centigrade

Table 3.4

3.8 Parameter Access

- * When the **PROG** (or **SHIFT-PROG**) key is pressed after the application of power or a fault reset, **21-MODE** will always be the first parameter displayed. See Section 4.1 for programming instructions.
- * If a different parameter is accessed and the Program mode is exited, that parameter will be the point of entry the next time the Program mode is accessed.
- * The 900AC Series will remember a different "last parameter accessed" for Levels 1 and 2.
- * If no key is pressed for 10 minutes while in the Program mode, the drive will automatically revert back to the operating mode.

3.9 Display Scroll Rate

Three scroll rates are used to speed data entry.

- * If either the **UP** or **DOWN** arrow is pressed and held for five seconds, the scroll rate will increase.
- * If **SHIFT** key is momentarily pressed while pressing one of the arrow keys, the five second delay will be bypassed.
- * If **SHIFT** key is pressed a second time while pressing an arrow key, the display will scroll at the fastest rate.

3.10 Restoring Factory Settings

- * Whenever a parameter data code is being changed (noted by **PRG** flashing) the original factory setting for that parameter can be restored by pressing and releasing both the **UP** and **DOWN** arrows simultaneously and then pressing the **ENTER** key.
- * To restore **ALL** parameters to factory settings, or recall a previously stored parameter set, see Section 4.2 **81-PRGNO**.

3.11 Quick Start for Chassis Models without Keypad*

This section is for operators with simple applications who would like to get up and running quickly. This section assumes that the 900AC Series controller was purchased from the supplier as a Chassis model with no keypad.

***Note:** For **Chassis models** that will be used **with external keypad**, use parameter **21-MODE** (Reference Section 4 - Parameter Descriptions and Programming); must be set to a value of 0, 2, 4, or 10 per application.

- Perform all procedures for installation as specified in Section 2 - Installation Instructions. **REVERIFY THAT THE PROPER VOLTAGE IS CONNECTED TO THE INVERTER BEFORE APPLYING POWER. FAILURE TO DO THIS CAN RESULT IN PERSONAL INJURY AND EQUIPMENT FAILURE!**
- Refer to Figure 5.2 for Fwd/Rev and Stop switch wiring.
- Refer to Figure 5.4 for Input Signal Wiring.
- Upon power up, the Forward and Reverse switches must be open prior to application of AC power.

3.12 Quick Start for Enclosed Models

This section is for operators with simple applications who would like to get up and running quickly and with a minimum amount of reading of the manual. **Be sure to read sections 3.1 through 3.8 before proceeding.** In many cases your 900AC Series will perform perfectly without making any changes to the factory settings. This section assumes that the 900AC Series has either a standard keypad or remote keypad attached. If remote operators are being used, substitute the speed potentiometer for the Up and Down arrows and the remote Run/Stop switch for the FWD key in the following instructions.

- Perform all procedures for installation as specified in Section 2 - Installation Instructions. **REVERIFY THAT THE PROPER VOLTAGE IS CONNECTED TO THE INVERTER BEFORE APPLYING POWER. FAILURE TO DO THIS CAN RESULT IN PERSONAL INJURY AND EQUIPMENT FAILURE!**
- Apply AC power to the input terminals. For about two seconds the display will show all segments active (See Figure 3.2). The STATUS indicator will then turn red (indicating a Stop condition) and the display will change to:



Figure 3.3

- The factory settings are for keypad only operation in the forward direction. This means that the REV key is disabled. Press the FWD key, the display will change to:

(continued on following page)

(continued)



Figure 3.4

- D. Press the UP Arrow to increase the desired running frequency. When the display gets to 0.1 Hz, the inverter will start to produce an output. When the motor starts to turn, check the rotation. If the motor is turning in the wrong direction, **PRESS STOP, REMOVE AC POWER AND WAIT FOR ALL INDICATORS TO GO OUT.** After the STATUS indicator has gone out, reverse any two of the motor leads at M1, M2 or M3.
- E. The length of time that the UP Arrow is pressed determines the scroll rate of the display. After it is held for five seconds, the rate of change will increase. The five second time can be circumvented by momentarily pressing the SHIFT key while holding the UP (or DOWN) Arrow.
- F. The inverter is preset to run a “typical” NEMA B 4-pole induction motor to a maximum speed of 60.00 Hz with both Acceleration and Deceleration times set to 3.0 seconds (see the Parameter Code Summary for a complete list of all factory settings).
- G. Use the Arrow keys to set proper running speed of the motor and the FWD and STOP keys to control it's operation.

SECTION 4

PARAMETER DESCRIPTIONS AND PROGRAMMING

Level 1 - Accesses only basic operator parameters.

Level 2 - Accesses all parameters including those in Level 1.

4.1 Programming

Refer to Figures 3.1 and 4.1. To change the default data code in a given parameter:

- A. Press the **STOP** key to stop the inverter if running.
- B. Press the **PROG** key to enter Level 1 Program mode. To enter Level 2 press and hold the **SHIFT** key and then the **PROG** key. The **PRG** indicator will turn on.
- C. Press the **UP/DOWN** arrow keys to access the desired parameter. The parameter number will be displayed in the upper left corner of the digital display.
- D. Press the **SHIFT** key to allow the Data Code to be changed. **PRG** will start to blink.
- E. Press the **UP/DOWN** arrows to select the new Data Code.
- F. Press the **ENTER** key to store the new Data Code. The display shows **STORed** for one second.
- G. Press the **PROG** key to exit the Program mode or the **UP/DOWN** arrows to select a new parameter.



Figure 4.1

4.2 Parameter Descriptions

This section provides functional descriptions of all 900AC Series parameters. Level numbers with an asterisk (*) indicate parameters that cannot be programmed, only viewed.

Note: Setting resolution is 0.05 up to 99.95 and 0.1 above this point unless otherwise noted.

<u>Parameter</u>	<u>Units</u>	<u>Level</u>
02-RVLVL - Software Revision		L2*
This parameter holds the identification code of the Read Only Memory.		
03-IRAT - Inverter Rated Current	[A]	L2*
This defines the nominal output current of the inverter and serves as the 100% reference for all current measurements. Continuous drive capacity is 1.1 times 03-IRAT.		
07-FLT3 - Last Fault		L1*

Parameter	Units	Level
08-FLT2 - Second Fault		L2*
09-FLT1 - First Fault		L2*
This defines the most recent faults. The two left most digits are the fault code, and the right most is elapsed time in 0.1 hr increments, since the last restart of the drive, 0.9 hours max. (see Section 6.2).		
12-FOUT - Motor Output Frequency	[Hz]	L1*
Inverter output frequency (Hz) applied to the motor.		
13-VOUT - Motor Output Voltage	[%]	L1*
Motor output voltage calculated as a percent of applied line input voltage.		
14-IOUT - Motor Output Current	[A]	L1*
Motor phase current computed to an accuracy of $\pm 20\%$.		
15-LOAD - Drive Load	[%]	L1*
True part of motor current. Output current measurement with motor power factor applied. Accuracy is $\pm 20\%$. Load reading is positive in motoring mode, and negative in regenerative mode.		
16-TORQ - Load Torque	[%]	L1*
Torque output of the motor. Computed from 15-LOAD, taking into account constant horsepower operation when 12-FOUT is greater than 53-FKNEE. Regenerative torque is shown with a negative sign.		
17-TEMP - Drive Temperature	[$\frac{1}{2}$ C]	L1*
Inverter heatsink temperature. The inverter will turn off when this temperature exceeds its maximum allowed temperature. This display is accurate to $\pm 3\frac{1}{2}$ C.		
21-MODE - Input Mode		L1
The MODE parameter defines the source for speed reference and Run/Stop control input.		

DATA CODE	SPEED CONTROL	START/STOP CONTROL
0	KEYPAD	KEYPAD (FWD Only)
10	KEYPAD	KEYPAD (FWD & REV)
1	VIN TERMINAL	KEYPAD (FWD Only)
11	VIN TERMINAL	KEYPAD (FWD & REV)
2	KEYPAD	TERMINALS (2-wire maintained contact)
3	VIN TERMINAL	TERMINALS (2-wire maintained contact)
4	KEYPAD	TERMINALS (3-wire momentary, RUN/JOG via PS3)
5	VIN TERMINAL	TERMINALS (3-wire momentary, RUN/JOG via PS3)
6	EMOP	TERMINALS (2-wire, see Section 5.6 and table below)
7	EMOP	TERMINALS (3-wire, see Section 5.6 and table below)

EMOP Control Terminal Logic Table

DESCRIPTION	FWD	REV	PS1	PS2
STOP	0	0	X	X
Speed = 0	1	1	X	X
FWD Decrease	1	0	1	X
FWD Hold	1	0	0	0
FWD Increase	1	0	0	1
REV Decrease	0	1	1	X
REV Hold	0	1	0	0
REV Increase	0	1	0	1

X = "Don't Care"

Parameter **Units** **Level**

24-FSEL - Speed Setpoint Selector L2

Selects the setpoint characteristics and the offset if required. Also see J19 selection (see Section 2.12).

DATA CODE	OPERATION	OFFSET	INPUT SIGNAL
0	DIRECT	0	0-10 VDC, 0-5 VDC, 0-20mA
1	INVERSE	0	0-10 VDC, 0-5 VDC, 0-20mA
2	DIRECT	20%	4-20mA
3	INVERSE	20%	4-20mA

NOTE: DIRECT = maximum output (32-FMAX) at maximum input.

INDIRECT = minimum output (31-FMIN) at maximum input.

31-FMIN - Minimum Frequency [Hz] L1

Sets the minimum frequency to the motor. Programmable from 0 to 400 Hz. Minimum programmable output frequency is 0.1 Hz.

32-FMAX - Maximum Frequency [Hz] L1

Sets the maximum frequency to the motor. Programmable from 20 to 400 Hz. **Consult motor manufacturer if frequency is in excess of nameplate rating.**

33-F2 through 38-F7 - Preset Frequencies [Hz] L2

Programmable from 0-400 Hz. Selected with input terminals PS1, PS2 and PS3 (see Sections 2.11 and 5.6). May be set to a greater frequency than 32-FMAX, but the output **WILL NOT** exceed 32-FMAX when running. **Consult motor manufacturer if frequency is in excess of nameplate rating.**

39-FTL - Minimum Frequency in Torque Limit [Hz] L2

The parameter sets the lowest frequency that the drive will decelerate to when in torque limit. If the load is large enough to drive the inverter below this threshold, the drive will trip on overcurrent.

1. The rate of deceleration is set by 46-DECTL.
2. Programmable from 0 to 400 Hz. Factory set for 10 Hz.
3. To disable torque limit, set this to a data code greater than 32-FMAX.

41-RSEL - Ramp Selector L2

Selects the acceleration and deceleration ramps that control the motor and also enables the coast-to-stop function.

DATA CODE	DEFINITION
0	Ramp-to-stop with 42-ACC1 and 43-DEC1 active.
1	42-ACC1/43-DEC1 active in forward, 44-ACC2/45-DEC2 active in reverse.
2	42-ACC1/43-DEC1 active when the output frequency is less than preset frequency 37-F6, 44-ACC2/45-DEC2 active when output frequency is equal to or greater than 37-F6.
3	When 21-MODE is programmed for 2, 3 or 6, PS3 is redefined as the alternate ramp time (ART) selector. When this terminal is active, 44-ACC2 and 45-DEC2 are selected. Note that PS3 cannot be used as a preset speed selector when 41-RSEL = 3 (see Table 2.2 & 21-MODE).
4	Same as 0, except coast-to-stop is selected when stopping.
5	Same as 1, except coast-to-stop is selected when stopping.
6	Same as 2, except coast-to-stop is selected when stopping.
7	Same as 3, except coast-to-stop is selected when stopping.

42-ACC1 - Acceleration Time #1 [s] L1

Sets the length of time to accelerate from 0 Hz to 32-FMAX. Programmable from 0.1 to 600 seconds. Extremely short acceleration times may result in nuisance fault trips (see 41-RSEL).

43-DEC1 - Deceleration Time #1 [s] L1

Sets the length of time to decelerate from 32-FMAX to 0 Hz. Programmable from 0.1 to 600 seconds. Extremely short deceleration times may result in nuisance fault trips or may require external dynamic braking resistor - consult factory (see 41-RSEL).

44-ACC2 - Acceleration Time #2 [s] L2

Alternate acceleration ramp. Sets the length of acceleration time from 0 Hz to 32-FMAX. Programmable from 0.1 to 600 seconds. Extremely short accel times may result in nuisance fault trips (see 41-RSEL).

Parameter

Units ... Level

45-DEC2 - Deceleration Time #2

[s] L2

Alternate deceleration ramp. Sets the length of time to decelerate from 32-FMAX to 0 Hz. Programmable from 0.1 to 600 seconds. Extremely short decel times may result in nuisance fault trips or may require external dynamic braking resistor - consult factory (see 41-RSEL).

46-DECTL - Deceleration Time in Torque Limit

[s] L2

This parameter sets the deceleration rate when the drive is operating in torque limit mode. Programmable from 0.1 to 30 seconds. It also serves as the acceleration rate when the drive is in torque limit due to a regenerative condition (see 39-FTL).

47-DCBRK - DC Brake Time

[s] L2

This is the time in seconds that DC current will be applied to motor windings with the following conditions:

1. Data Code = 0
 - A. DC braking disabled in all modes.
2. Data Code = 0.05 - 4.95 (Timed DC braking)
 - A. In terminal strip Stop/Start, when both FWD and REV terminals are active.
 - B. In FWD or REV run mode and the speed reference is reduced to less than 0.1 Hz.
 - C. A Stop command is given and the output frequency decelerates to less than 0.1 Hz.
3. Data Code = 5 (Continuous DC braking)
 - A. In terminal strip Start/Stop, as long as both FWD and REV terminals are held active.
 - B. In FWD or REV run mode and the speed reference is reduced to less than 0.1 Hz.
 - C. There is no DC braking after a normal deceleration to stop.

48-DCVLT - DC Brake Voltage

[%] L2

This controls the amount of DC voltage applied to the motor windings by 47-DCBRK. Programmable from 0 to 15% of the input voltage. Factory setting is 2/3 of 52-BOOST.

CAUTION: If DC Braking is used as a holding brake, excessive motor heating may result.

51-VSEL - V/Hz Characteristic Selector

L2

Three V/Hz characteristics (constant torque, pump and fan curves) and two starting torque boost features may be selected.

DATA CODE	DESCRIPTION
0	Linear V/Hz, with Auto-Boost, used with constant torque applications. With Auto-Boost, the optimum boost will be selected depending on load and motor conditions, parameter 52-BOOST sets the maximum boost applied.
1	Linear V/Hz, with constant boost fixed by 52-BOOST.
2	Mixed (linear/quadratic) V/Hz, with Auto-Boost, typical of pumping applications.
3	Mixed V/Hz, with constant boost fixed by 52-BOOST.
4	Quadratic V/Hz, with Auto-Boost, for fan-law applications.
5	Quadratic V/Hz, with constant boost fixed by 52-BOOST.

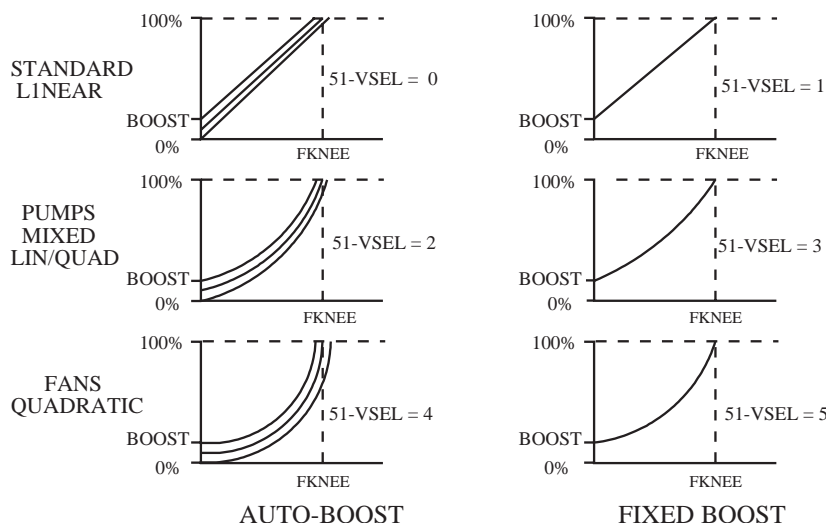

Figure 4.2

<u>Parameter</u>	<u>Units</u>	<u>Level</u>
------------------	--------------	--------------

52-BOOST - Torque Boost	[%]	L1
--------------------------------	-----	----

This parameter increases motor voltage at low speed as a percent of nominal voltage to increase the starting torque of the motor. Voltage boost will linearly decrease with increasing speed. Default boost settings vary between models.

53-FKNEE - V/Hz Knee Frequency	[Hz]	L2
---------------------------------------	------	----

This parameter sets the point on the frequency scale at which the output is at full line voltage. Programmable from 26 to 960 Hz. This is normally set at the base frequency of the motor but may be increased to enlarge the constant torque range on special motors. Setting FKNEE to a higher value can reduce motor losses at low frequencies.

59-MVOLT – Rated Motor Voltage	[V]	L2
---------------------------------------	-----	----

This sets the voltage the inverter delivers to the motor terminals at the setting of 53-FKNEE. 230 volt models are programmable from 185 to 240 volts. The drive will attempt to regulate the output voltage with a changing input voltage to better than 5%.

61-LTLF - Load Torque Limit Forward	[%]	L2
--	-----	----

62-LTLR - Load Torque Limit Reverse	[%]	L2
--	-----	----

63-RTL - Regenerative Torque Limit Forward	[%]	L2
---	-----	----

64-RTL - Regenerative Torque Limit Reverse	[%]	L2
---	-----	----

These four parameters set the torque limiting points for the inverter in both motoring and regenerative modes with individual settings for forward and reverse operation. Programmable in 1% increments from 30 to 150% (110% in regenerative modes). TO DISABLE TORQUE LIMITING SET 39-FTL TO A VALUE GREATER THAN 32-FMAX.

65-SLIP - Slip Compensation	[%]	L1
------------------------------------	-----	----

This parameter allows for compensation of slip in standard NEMA rated induction motors. Programmable from 0 to 12%. **DO NOT USE THIS FUNCTION WITH SYNCHRONOUS MOTORS, AS GROSS INSTABILITY MAY OCCUR.** Slip compensation is calculated as follows:

$$65-SLIP = SLIP \times (IRAT/FLA) \times 100$$

Where: IRAT = Data Code in 03-IRAT

FLA = Motor Nameplate Current

SLIP = (sync. speed - nameplate speed)/sync. speed

This parameter is inactive for 65-SLIP = 0

66-STAB - Current Stability Adjustment

Lightly loaded motors may tend to oscillate and become unstable due to electromechanical relationships in the motor. This may be more prevalent when the inverter capacity is larger than the motor. This adjustment will stabilize the motor current in these conditions. The value of 66-STAB is either 0 or 1, with the default being 1.

67-TOL - Timed Overload Trip Point	[%]	L1
---	-----	----

This parameter defines the level of load that will cause a timed electronic overload trip to occur. Programmable in 1% increments from 0 to 100%. Trip time depends on overload severity, and is 1 minute for 150% of the 67-TOL setting. 67-TOL is active between 30 & 100% of the inverter rated current (03-IRAT).

NOTE: When operating multiple motors from a single inverter, use a separate external motor protection device on each motor and set parameter 67-TOL to its factory setting of 0 (disabled).

Timed Overload is calculated as follows:

$$TOL = (FLA/IRAT) \times 100$$

Where:

IRAT = Data Code in 03-IRAT

FLA = Motor Nameplate Current

This parameter is inactive for 67-TOL = 0

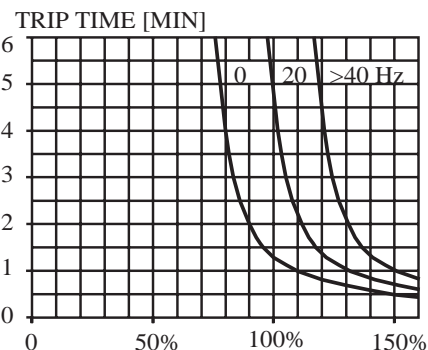

Figure 4.3

<u>Parameter</u>	<u>Units</u>	<u>Level</u>
68-NRST - Trip Restart Number		L2

WARNING - This function requires maintained contact Run/Stop control to function. Insure that automatic restarting will not cause injury to personnel or damage to equipment.

IF THE SETTING OF 68-NRST HAS BEEN EXCEEDED AND FAULT F10 IS DISPLAYED, RESETTING THE FAULT WILL RESULT IN AN IMMEDIATE START. INSURE THAT SUCH RESTART WILL NOT CAUSE INJURY TO PERSONNEL OR DAMAGE TO EQUIPMENT.

The inverter will automatically perform a reset, after delay set by 69-DRST, from 1 to 8 times when any fault trip with a code of F11 and greater has occurred. If the FWD or REV terminal is still active (2-wire operation) the inverter will attempt a restart (See 21-MODE and Section 5.2). The count will reset if a another fault is not incurred within 10 minutes. If the programmed count is exceeded within 10 minutes, the inverter will not restart, but will display a fault trip message F10. **RESETTING THE FAULT CAN RESULT IN INSTANT STARTING. SEE WARNING ABOVE.**

This function is inactive for 68-NRST = 0.

69-DRST - Restart Delay Time	[s]	L2
-------------------------------------	-----	----

After a fault trip of F11 or greater has occurred, and 68-NRST is greater than zero, the inverter will wait for the specified number of seconds before attempting a restart. Programmable from 0 to 60 seconds in 1 second increments. Restart will be controlled by the setting of 82-START

70-MCAL - Analog Meter Output Calibration	L1
--	----

This parameter adjusts the meter output value at terminal MET. Programmable from 0 to 255. **70-MCAL can be programmed while the inverter is running.**

Factory default is for 10 VDC at terminal MET, at nominal full scale output.

71-METER - Analog Meter Output Selector	L1
--	----

This parameter selects the analog output signal to be indicated at terminal MET. The factory full scale setting is 10 VDC but can be changed using parameter 70-MCAL.

DATA CODE	DESCRIPTION
0	Output off
1	Output proportional to output frequency (12-FOUT), with full scale at 32-FMAX.
2	Output proportional to output current (14-IOUT), with full scale at 200% of rated current.
3	Output proportional to inverter load (15-LOAD), with full scale at 200% of rated load.

75-STR - Auxiliary Relay Output	L1
--	----

The relay furnished with the inverter may be programmed to respond to any of the 10 conditions listed below (see Section 2.11).

DATA CODE	DESCRIPTION
0	Off
1	Ready. The relay becomes active when the inverter is ready. It is inactive in fault, low voltage and program modes.
2	Fault. The relay becomes active on fault (see note below).
3	Motor running forward or reverse, and output frequency above 0.5 Hz.
4	Motor running reverse, and output frequency above 0.5 Hz.
5	Motor running forward, and output frequency above 0.5 Hz.
6	Motor speed = less than 0.5 Hz.
7	Motor at commanded speed.
8	Motor speed greater than preset speed 36-F5.
9	In torque limit.
10	Over temperature warning. Temperature is within 10½C of maximum temperature.

NOTE: When automatic fault reset and restart is used (68-NRST), a fault will not be indicated until 68-NRST has been exceeded.

Parameter**Units****Level****77-MOL** - Motor Overload Input

L2

Sets motor overload input function and polarity. This parameter, along with **J19** jumper selection, define the function of the **MOL** input terminal. It can be defined to generate an F07 fault or a coast-to-stop condition using either normally open or normally closed contacts. **J19** sets the input terminals for pull-up or pull-down logic (see Section 2.12).

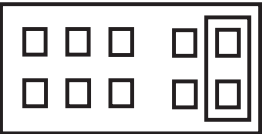
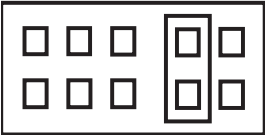
J19	DATA CODE	DESCRIPTION (MOL DESCRIPTION)
	0	High input (V+) or external signal (max +24 VDC referenced to CM) will generate an F07 fault (N.O. operation).
	1	Removal of high input (V+) or external signal will generate an F07 fault (N.C. operation).
	2	High input (V+) or external signal (max +24 VDC referenced to CM) will generate a coast-to-stop (N.O. operation).
	3	Removal of high input (V+) or external signal will generate a coast-to-stop (N.C. operation).
	0	Connecting MOL to CM will generate an F07 fault (N.O. operation).
	1	Opening MOL-CM connection will generate an F07 fault (N.C. operation).
	2	Connecting MOL to CM will generate a coast-to-stop (N.O. operation).
	3	Opening MOL-CM connection will generate a coast-to-stop (N.C. operation).

NOTE: External thermal overload relay rating = 1.1 x motor continuous nameplate amps.

81-PRGNO - Special Program Number

L2

This parameter allows for storing and resetting parameters and activating special functions. The function will be executed upon exiting the Program mode.

DATA CODE	DESCRIPTION
0	Standard Program
1	Reset parameters to factory settings (Display = SETP)
2	Store customer parameter settings (Display = STOC)
3	Recall customer parameter settings (Display = SETC)

82-START - Start Options

L2

Controls the operation of line start lockout and/or auto-start into a rotating motor. Additionally enables or disables both the STOP key as an E-Stop when operating from the terminal strip and the stop function due to a disconnection of a remote device connected to the drive through connector J22. See Section 6.1 for special display indications used with this parameter.

WARNING - STARTING INTO A ROTATING MOTOR

When this function is selected, the inverter will attempt to run the motor at 60 Hz output and reduced voltage. It then lowers that frequency until output current is minimized and the motor and frequency are synchronized. A LIGHTLY LOADED MOTOR MAY SUDDENLY ACCELERATE BEFORE LOCKING IN THE PROPER SPEED. INSURE THAT THIS OPERATION WILL NOT CAUSE INJURY TO PERSONNEL OR DAMAGE TO EQUIPMENT.

(continued on following page)

(Continued from 82-START)

DATA CODE	DESCRIPTION
0	Line start lockout. If maintained contact run operators are used, they must be opened and then re-closed for the drive to start after application of AC power. STOP key active as emergency, coast-to-stop, for 21-MODE = 2-7. To reset an E-Stop, press the STOP key again. No stop with signal loss at connector J22.
1	Auto-start. Will start on power-up if direction connection is made at the control terminals after application of AC power. STOP key active as emergency, coast-to-stop, for 21-MODE = 2-7. To reset an E-Stop, press the STOP key again. No stop with signal loss at connector J22.
2	Start into a rotating motor with line start lockout (see note on starting into a rotating motor). STOP key active as emergency, coast-to-stop, for 21-MODE = 2-7. To reset an E-Stop, press the STOP key again. No stop with signal loss at connector J22.
3	Start into a rotating motor with auto-start. STOP key active as emergency, coast-to-stop, for 21-MODE = 2-7. To reset an E-Stop, press the STOP key again. No stop with signal loss at connector J22.
4-7	Same start functions as data codes 1-3, but keypad STOP key will be disabled if start/stop is defined as terminals by 21-MODE. No stop with signal loss at connector J22.
8-11	Same start functions as data codes 1-3, but drive will initiate a stop function (as defined by 41-RSEL) if a remote device signal is sensed at connector J22 and then lost.

Parameter

Units Level

84-DISP - Display Option Setting

L2

This parameter determines information displayed on the LCD readout during run operation. The display will always show frequency in the stop mode and while the speed is being set.

DATA CODE	DESCRIPTION
0	Output frequency in Hz (value of 12-FOUT).
1	Output current in amps (value of 14-IOUT).
2	Drive load in percent (value of 15-LOAD).
3-3000	Display indicates rpm . Number displayed x 20 / 12-FOUT = Data code Example: To display 1800 rpm at 60 Hz: $1800 \times 20 / 60 = 600$ Note: Data code must be rounded to nearest whole number.

Parameter

Units Level

87-ACODE - Security Access Code

L2

Entering a number between 1 and 999 provides controlled access to program parameters (both Level 1 and Level 2). After an access code has been entered, the initial display will indicate:



After the proper security code is entered, the display will return to the normal Programming mode display. At this point, the user has 10 minutes of free access unless power is removed and reapplied.

SECTION 5 - CONNECTION DIAGRAMS

Warning: Twist wires together before inserting in terminals.

The following show some of the commonly used connections for operating the 900AC series from external devices. Refer to Section 2.11 for more information on the control input terminals.

5.1 AC Line and Motor Connections

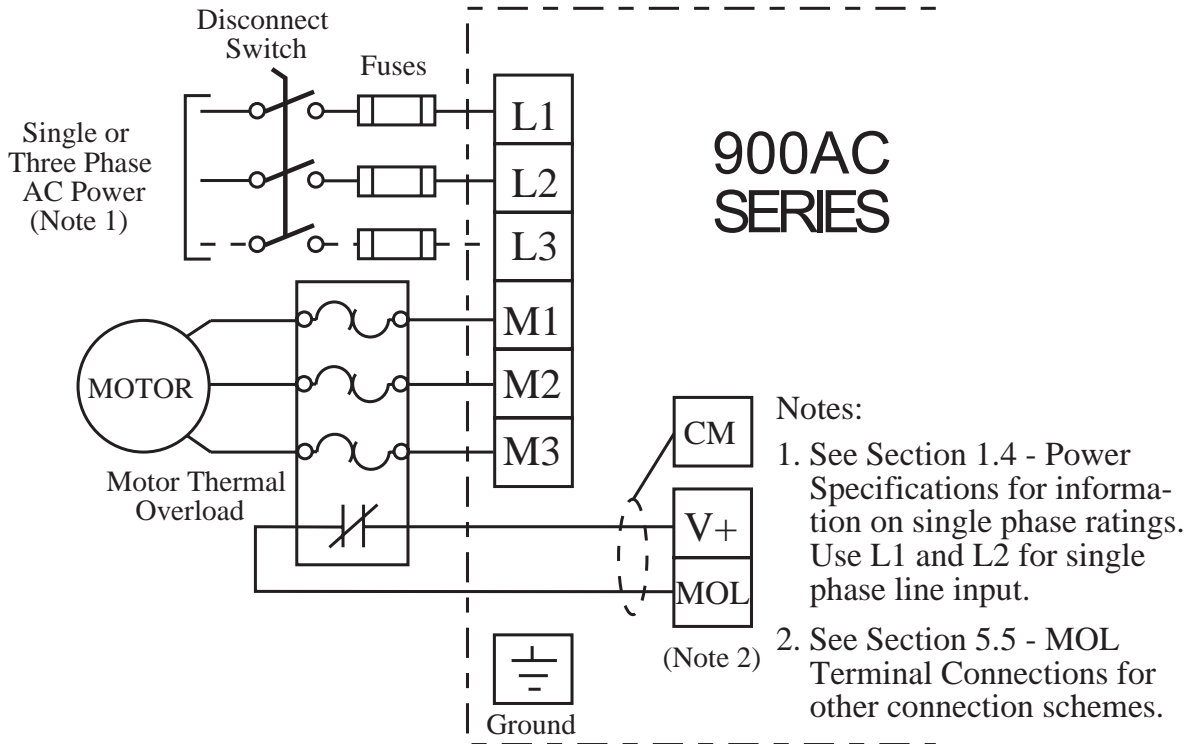
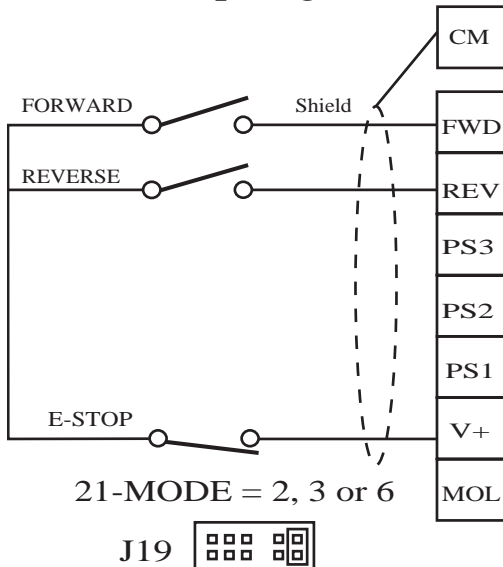

Figure 5.1

5.2 Two-wire Run/Stop Connections

Pull-Up Logic



Pull-Down Logic

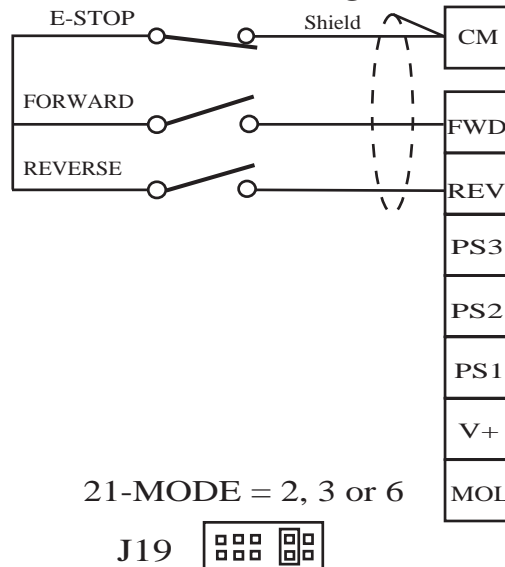

Figure 5.2

5.3 Three-wire Run/Stop Connections

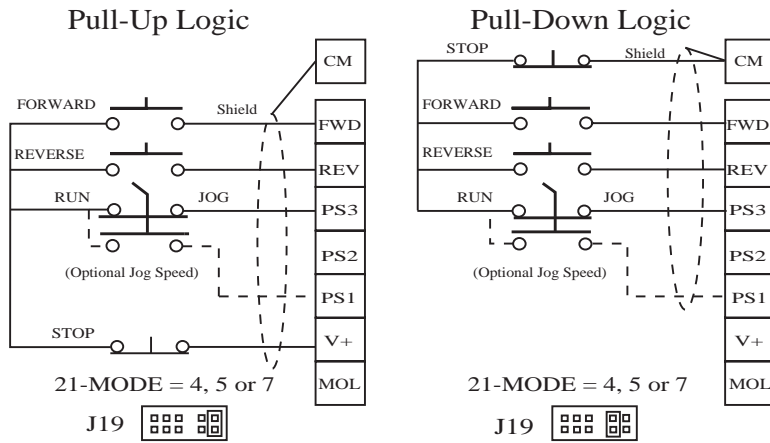

Figure 5.3

5.4 Analog Speed Input Connections

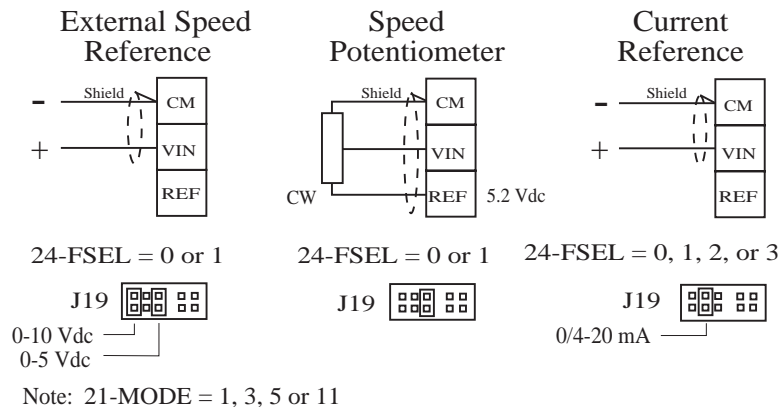
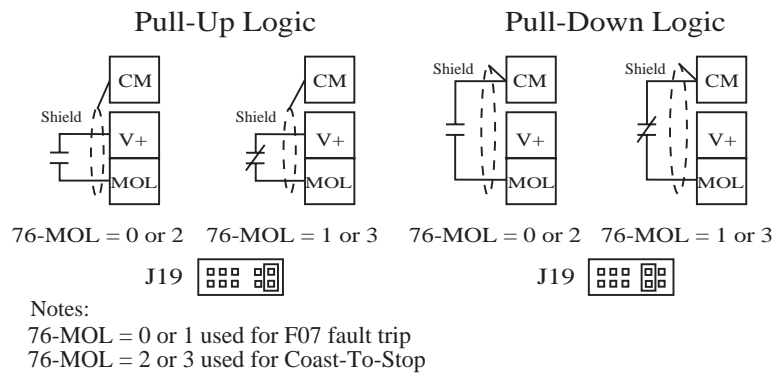

Figure 5.4

5.5 MOL Terminal Connections



Notes:

77-MOL = 0 or 1 used for F07 fault trip
 77-MOL = 2 or 3 used for coast-to-stop

Figure 5.5

5.6 Optional Connections

Preset Speed Selection

Pull-Up Logic

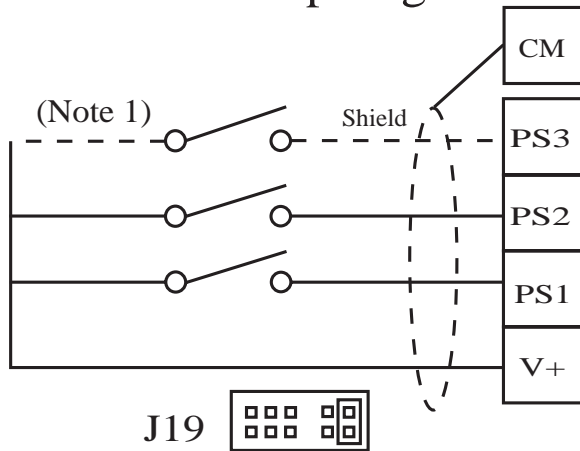

Pull-Down Logic

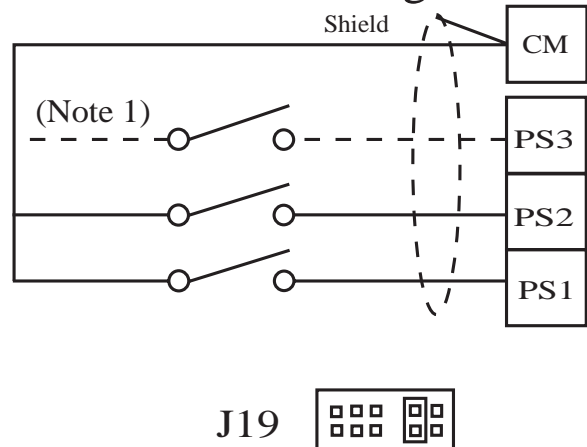

EMOP Selection

Pull-Up Logic

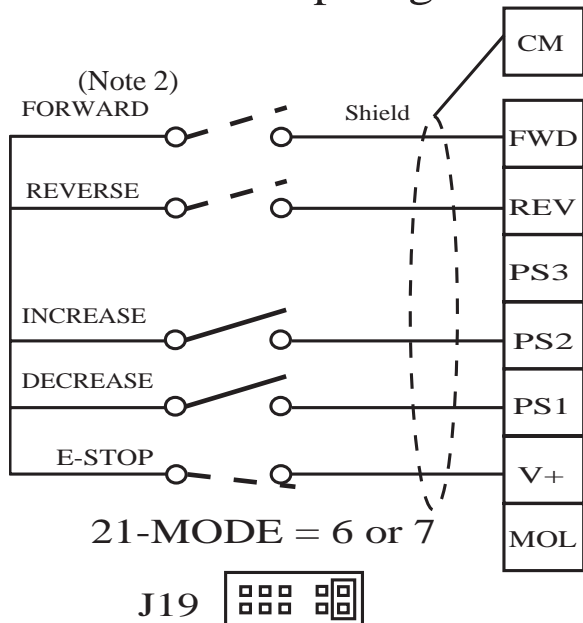

Pull-Down Logic

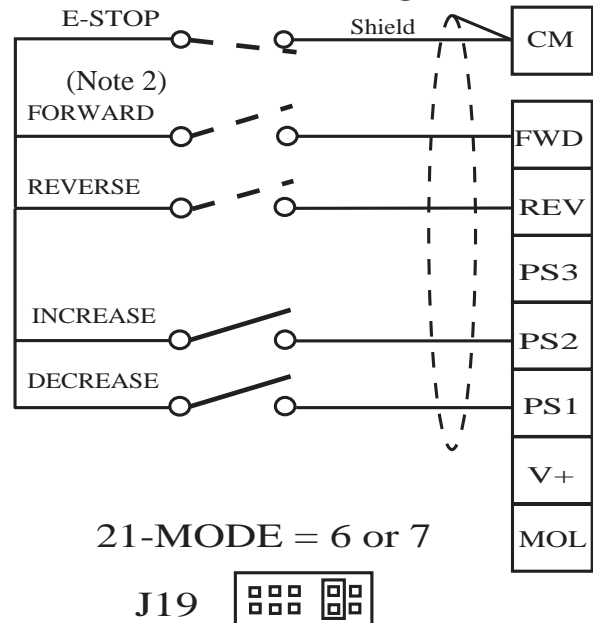

Analog Meter

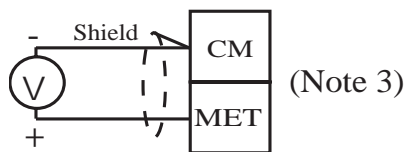

Notes:

1. See Section 2.11, Table 2.2
2. See Section 4.2, 21-MODE
21-MODE = 6 used for 2-Wire operation
21-MODE = 7 used for 3-Wire operation
3. See Section 4.2, 71-METER

Figure 5.6

SECTION 6 - TROUBLESHOOTING

WARNING - POTENTIAL DANGER

Warning: Disconnect electrical supply before servicing the electrical system.

6.1 Special Indications

In addition to the standard operation and programming displays several special displays may appear:

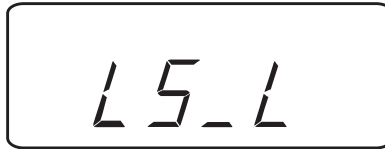

Figure 6.1

Line Start Lockout
See 82-START in Section 4.2



Figure 6.2

Emergency Stop
See 82-START in Section 4.2

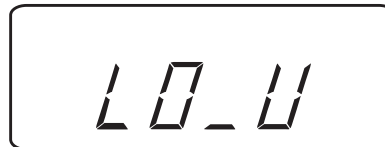

Figure 6.3

Low Voltage
AC line voltage is too low.

6.2 Fault Trip Indications

In the event of a fault trip, the STATUS indicator will begin to blink red (see Section 3.6) and the display will show the fault code as shown in Figure 6.4.



Figure 6.4

Pressing the UP arrow before the fault is reset will display the status of the drive at the time of the fault as shown in Figure 6.5.

Note that more than one annunciator may be displayed to better define the cause of the fault. Additional information concerning the drive status at the time of the fault is available by pressing the PRG key and viewing parameters 12 through 17.



Figure 6.5

6.3 Resetting a Fault

Faults can be reset in any one of four (4) ways:

- Pressing the STOP key on the keypad (if present).
- Activating and then deactivating both the FWD and REV terminals simultaneously.
- Removing and restoring AC power.
- Using the automatic restart function 68-NRST, see Section 4.2.

6.4 Fault Codes

FAULT	CAUSE	REMEDY
F01	Computer malfunction	1. Reset the drive using the stop key for longer than 1 second. 2. If the problem persists, consult the factory.
F02	Parameter Block Fault	1. Restore all parameters to factory settings by entering 81-PROG = 1. 2. If the problem persists, consult the factory.
F03	Bus Current Measurement Fault	1. Reset the fault by pressing the stop key. 2. If the problem persists, consult the factory.
F04	Power Supply Overload	1. Check for excessive loading on control terminals REF and +V. See section 2.11.
F05	No DC Bus Voltage	1. Check for proper source voltage. 2. Check for DB component or output transistor failure. 3. Check for shorted DC bus.
F06	Output Short Circuit	1. Check motor wiring. 2. Reduce 52-BOOST. 3. Extend 42-ACC1 accel ramp.
F07	External Fault Mechanism (Motor Overload Relay) tripped	1. Check motor wiring. 2. Verify the sizing of MOL.
F10	Auto-Restart (68-NRST) number exceeded	1. Check the fault log (07-FLT3, 08-FLT2, and 09-FLT1). 2. Institute corrective action for those faults. NOTE: RESETTING THIS FAULT MAY CAUSE INSTANT STARTING. INSURE THAT DOING SO WILL NOT CAUSE HARM TO PERSONNEL OR DAMAGE TO EQUIPMENT.
F11	Ground Fault	1. Check motor wiring. 2. Check for and remove any capacitive load.
F13	Overvoltage on DC bus	1. Verify line voltage. 2. Excessive regenerative load. 3. Increase deceleration time. 4. Reduce preset regenerative current limit value.
F16	Acceleration Overcurrent	1. Increase acceleration ramp time. 2. Check motor wiring for short circuit. 3. Check for "normal" operation with motor disconnected.
F17	Deceleration Overcurrent	1. Increase deceleration ramp time. 2. Reduce preset regenerative current limit value.
F18	Running Overcurrent	1. Locate cause of mechanical overload on the motor.
F19	Heatsink Over Temperature	1. Check for excessive overload. 2. Verify the proper sizing of the drive for the application. 3. Locate the drive in a cooler location, out of direct sunlight.
F20	Timed Overload	1. Check programming of 67-TOL. 2. Check for overload on the motor.

- Notes:
1. Faults **F01-F11** are checked during the power-up sequence.
 2. **F02** is also checked during programming.
 3. Faults **F11-F20** will be reset if the Auto-Restart function is selected (see 68-NRST).

6.5 Troubleshooting

PROBLEM	CHECKPOINT	CORRECTIVE ACTION
Motor is not running	Incorrect wiring	1. Check all power and control wiring.
	External Frequency Command (if used)	1. Verify that the external frequency control signal is properly connected. 2. Verify the integrity of the frequency control potentiometer.
	Programming Selections	1. Verify that the proper programming selections have been made for the application.
	Fault	1. Verify that the inverter has not shutdown due to a fault condition. 2. Consult section 6.4.
	Motor Stall	1. Release any overload on the motor. 2. Verify that adequate torque boost is available.
Motor Speed Fluctuation	Loose Terminal Connection	1. Stop the inverter, turn off power and tighten all terminal screws. 2. Check for tightness of all connections within the drive.
	Frequency Control Pot Erratic	1. Replace frequency control potentiometer.
Motor Speed too High or too Low	Frequency Profile	1. Verify that the setting of 31-FMIN, 32-FMAX, and 53-FKNEE are correct for the motor specification and application.
	Frequency Control Signal	1. Verify the input signal level.
	Motor Nameplate Specifications	1. Verify that the motor selection is proper for the application.

900AC SERIES MICRO-INVERTER - PARAMETER CODE SUMMARY

PARAMETER	DESCRIPTION	RANGE (FACTORY SETTING)	PAGE	CUSTOMER SETTING
02-RVLVL	Software Revision	Note 1	14	
03-IRAT	Inverter Rated Current	Note 1	14	
07-FLT3	Last Fault	Note 1	14	
08-FLT2	2nd Fault	Note 1	15	
09-FLT1	1st Fault	Note 1	15	
12-FOUT	Motor Output Frequency	0-400 Hz	15	
13-FOUT	Motor Output Voltage	0-100% of line voltage	15	
14-IOUT	Motor Output Current	0-60	15	
15-LOAD	Drive Load	0-200% of 03-IRAT	15	
16-TORQ	Load Torque	0-200%	15	
17-TEMP	Drive Temperature	0-100°C	15	
21-MODE	Input Mode	00-11 (Note 2)	15	
24-FSEL	Speed Setpoint Selector	0-3 (0)	16	
31-FMIN	Minimum Frequency	0-400 Hz (0)	16	
32-FMAX	Maximum Frequency	20-400 Hz (60)	16	
33-F2	Preset Frequency #2	0-400 Hz (5)	16	
34-F3	Preset Frequency #3	0-400 Hz (20)	16	
35-F4	Preset Frequency #4	0-400 Hz (40)	16	
36-F5	Preset Frequency #5	0-400 Hz (60)	16	
37-F6	Preset Frequency #6	0-400 Hz (0)	16	
38-F7	Preset Frequency #7	0-400 Hz (0)	16	

(continued on following page)

900AC SERIES MICRO-INVERTER - PARAMETER CODE SUMMARY (continued)

PARAMETER	DESCRIPTION	RANGE (FACTORY SETTING)	PAGE	CUSTOMER SETTING
39-FTL	Minimum Frequency in Torque Limit	0-400 Hz (10)	16	
41-RSEL	Ramp Selector	0-7 (0)	16	
42-ACC1	Acceleration Time #1	0.1-600 sec (3)	16	
43-DEC1	Deceleration Time #1	0.1-600 sec (3)	16	
44-ACC2	Acceleration Time #2	0.1-600 sec (1)	16	
45-DEC2	Deceleration Time #2	0.1-600 sec (1)	17	
46-DECTL	Deceleration Time in Torque Limit	0.1-30 sec (1)	17	
47-DCBRK	DC Brake Time	0-5 sec (0.2)	17	
48-DCVLT	DC Brake Voltage	0-15% (2/3 52-BOOST)	17	
51-VSEL	V/Hz Characteristic Selector	0-5 (0)	17	
52-BOOST	Torque Boost	0-25%	18	
53-FKNEE	V/Hz Knee Frequency	26-960 Hz (60)	18	
59-MVOLT	Rated motor Voltage	185-240	18	
61-LTLF	Preset Load Torque Limit FWD	30-150% (150)	18	
62-LTLR	Preset Load Torque Limit REV	30-150% (150)	18	
63-RTL F	Preset Regenerative Torque Limit FWD	30-110% (80)	18	
64-RTL R	Preset Regenerative Torque Limit REV	30-110% (80)	18	
65-SLIP	Slip Compensation	0-12% (0)	18	
66-STAB	Current Stability	0-1 (1)	18	
67-TOL	Timed Overload Trip Point	0-100% (0)	18	
68-NRST	Trip Restart Number	0-8 (0)	19	
69-DRST	Restart Time Delay	0-60 sec (0)	19	
70-MCAL	Analog Meter Output Selector	0-255 (set for 10 VDC)	19	
71-METER	Analog Meter Output Selector	0-3 (1)	19	
75-STR	Auxiliary Relay Output	0-10 (2)	19	
77-MOL	Motor Overload Input	0-3 (0)	20	
81-PRGNO	Special Program Number	0-9999 (0)	20	
82-START	Start Options	0-7 (0)	20	
84-DISP	Display Option Setting	0-3000 (0)	21	
87-ACODE	Security Access Code	0-999 (0)	21	

- NOTES:
1. See section 4.2 for definitions of data.
 2. Models with keypad: Data code = 0
Models without keypad: Data code = 3
 3. Level 1 parameters shown shaded.

NOTES:

NOTES:

REPAIR PROCEDURE

In the event that a Product manufactured by Dart Controls Incorporated (DCI) is in need of repair service, it should be shipped, freight paid, to: Dart Controls, Inc., 5000 W. 106th Street, Zionsville, IN. 46077, ATTN: Repair Department.

Please include with each order a P.O. number to cover any repair charges (a P.O. is needed even on warranty returns to cover misuse or other failures that have voided warranty), and include a note with a brief description of the problem experienced. **NO WORK WILL BE DONE ON ANY ORDER WITHOUT A P.O. NUMBER.**

Completed repairs are returned with a Repair Report that states the problem with the control and the possible cause. Repair orders are returned via UPS Ground unless other arrangements are made. If you have further questions regarding repair procedures, contact your Dart Distributor or Representative.

ALSO AVAILABLE FROM DART CONTROLS, INC.



125D SERIES
AC INPUT - VARIABLE DC OUTPUT
1/50 HP through 1.0 HP



250G SERIES
AC INPUT - VARIABLE DC OUTPUT
1/50 HP through 2.0 HP



65 SERIES
DC INPUT - VARIABLE DC OUTPUT
CURRENT RATINGS OF 20, 40, AND
60 AMPS



500 SERIES
AC INPUT - VARIABLE DC OUTPUT
1/50 HP through 3.0 HP



MDP SERIES
PROGRAMMABLE
CLOSED LOOP DC
SPEED CONTROL



DM SERIES
FIELD PROGRAMMABLE
DIGITAL TACHOMETER

Dart offers the industry's broadest range of electronic DC and AC motor speed controls rated to 3 horsepower, as well as speed control accessories.

Shown above is just a sampling of the expanded line of Dart controls that feature the latest in electronic technology and engineering. Products are manufactured in the U.S.A. at our Zionsville (Indianapolis, Indiana) production and headquarters

facility - with over 2,000,000 variable speed units in the field.

In addition to the standard off-the-shelf products, you can select from a wide variety of options to customize controls for your specific application. For further information and application assistance, contact your local Dart sales representative, stocking distributor, or Dart Controls, Inc.

Dart Controls, Inc.

Manufacturer of high quality DC and AC motor speed controls and accessories since 1963.

P.O. Box 10
5000 W. 106th Street
Zionsville, Indiana 46077
Phone: (317) 873-5211
Fax: (317) 873-1105