

530B CONTROL SERIES

DART

CONTROLS

Instruction Manual

Variable Speed DC Control



**P.O. Box 10
5000 W. 106th Street
Zionsville, Indiana 46077**

**Phone (317) 873-5211
Fax (317) 873-1105
www.dartcontrols.com**

TABLE OF CONTENTS

WARRANTY	1
INTRODUCTION	2
COMMONLY ASKED QUESTIONS	2
BASIC MODEL SELECTION	2
CONTROL FEATURES	3
OVERALL CONTROL DIMENSIONS	3-4
SPEEDPOT MOUNTING DIMENSIONS	4
MOUNTING INSTRUCTIONS	4
WIRING PROCEDURE	4
TERMINAL STRIP WIRING - P1	5
TERMINAL STRIP WIRING - P2	5-6
SETTING INPUT VAC	6
SWITCH LADDER CIRCUIT DIAGRAMS	6
“RE” CONTROL PANEL IDENTIFICATION	6
INITIAL START-UP	7
TRIMPOT ADJUSTMENT PROCEDURE	7-8
TRIMPOT SETTING CHART	8
1.5 AND 3.0 HORSEPOWER - MODEL 533BC	8
BASIC HOOK-UP DIAGRAM WITHOUT OPTIONS	9-10
530BC, 533BC & 530BRC HOOK-UP DIAGRAMS	9
PILOT RELAY SWITCHING	9
530BRE HOOK-UP DIAGRAM	10
JU2 JUMPER WIRE SELECTION CHART	10
CONTROL MODIFICATIONS	10-11
TWO SPEED OPERATION	10
DYNAMIC BRAKING	10
TACHOMETER FEEDBACK & FOLLOWER	11
INHIBIT INSTRUCTIONS	11
OPTIONS	11-15
-4 OPTION	11
-5 OPTION	12
-7 / -11 / -15A OPTIONS	13
-36M / -38M OPTIONS	14-15
IN CASE OF DIFFICULTY	15
FUSING	15
SPECIFICATIONS	16
530B SERIES PARTS PLACEMENT & LIST	17
530B SERIES SCHEMATIC	18
PRODUCT LINE	BACK COVER

WARRANTY

Dart Controls, Inc. (DCI) warrants its products to be free from defects in material and workmanship. The exclusive remedy for this warranty is DCI factory replacement of any part or parts of such product which shall within 12 months after delivery to the purchaser be returned to DCI factory with all transportation charges prepaid and which DCI determines to its satisfaction to be defective. This warranty shall not extend to defects in assembly by other than DCI or to any article which has been repaired or altered by other than DCI or to any article which DCI determines has been subjected to improper use. DCI assumes no responsibility for the design characteristics of any unit or its operation in any circuit or assembly. This warranty is in lieu of all other warranties, express or implied; all other liabilities or obligations on the part of DCI, including consequential damages, are hereby expressly excluded.

NOTE: Carefully check the control for shipping damage. Report any damage to the carrier immediately. Do not attempt to operate the drive if visible damage is evident to either the circuit or to the electronic components.

All information contained in this manual is intended to be correct, however information and data in this manual are subject to change without notice. DCI makes no warranty of any kind with regard to this information or data. Further, DCI is not responsible for any omissions or errors or consequential damage caused by the user of the product. DCI reserves the right to make manufacturing changes which may not be included in this manual.

WARNING

Improper installation or operation of this control may cause injury to personnel or control failure. The control must be installed in accordance with local, state, and national safety codes. Make certain that the power supply is disconnected before attempting to service or remove any components!!! If the power disconnect point is out of sight, lock it in disconnected position and tag to prevent unexpected application of power. Only a qualified electrician or service personnel should perform any electrical troubleshooting or maintenance. At no time should circuit continuity be checked by shorting terminals with a screwdriver or other metal device.

INTRODUCTION

The 530B Series is a high performance, dual voltage versatile DC motor control which provides a wide range of standard features, with many options that extend its capabilities. The 530B Series will operate 1/8 through 1.0 horsepower at 115VAC input, and 1/4 through 2.0 horsepower at 230VAC input. A chassis only model is available to operate a 1.5 horsepower motor at 115VAC input, or 3.0 horsepower at 230VAC input. Reference "Basic Model Selection" guide.

The 530B Series consists of three basic types:

- C** = Chassis mounted, no enclosure, no power relay's.
- RC** = Chassis mounted, no enclosure, with power relay's.
- RE** = Plastic enclosure with power relay's - Nema 4/12 standard.

The 530B Series is designed for Permanent Magnet, Shunt Wound, and some Universal Series (AC/DC) motors in the above horsepower ranges. The 530B Series incorporates transient voltage protection with adjustable Current Limit and AC fuses for protection. Minimum and Maximum speeds are easily adjusted by trimpots, as is the I.R. Compensation. Acceleration and Deceleration are fully adjustable via individual trimpots.

COMMONLY ASKED QUESTIONS

- Q. Can I run two or more motors from the same drive?**
A. Not recommended. The I.R. Compensation (regulation) and Current Limit circuits would have difficulty sensing the different load on each motor.
- Q. Can I change the horsepower of my motor and still use the same control?**
A. Yes, provided you do not deviate outside the horsepower range for the voltage you are using. The trimpots would need readjustment; see "Trimpot Chart" for approximate settings.
- Q. Can I use the 530B Series as a Current Follower?**
A. Yes, there is a field installable -5 or -7 option shown in "Options" section.
- Q. Can I use the 530B Series on Tachometer feedback?**
A. Yes, see +Tach (P2-9) under "Terminal Strip Wiring - P2".
- Q. Can I use the Stop (P2-11), Start (P2-13), and Common (P2-12) to stop-start the control on the "C" chassis version?**
A. No. Terminals P2-11, P2-12, and P2-13 are only active on the relay versions; "RE" and "RC". These terminals are non-operative on the "C" version.
- Q. Can the 530B Series be used as a Voltage or Tachometer Follower?**
A. Yes. The voltage must be ungrounded and no more than +12 VDC (See "Terminal Strip Wiring" for proper hook-up).
- Q. How would I proceed to stop/start the 530B Series with my own relay?**
A. You can use the contact of your relay in place of the AMP REF to REV 1 (P2-2 to P2-7) jumper wire. Since this is a low level signal (12 volts at 2mA), you must use a logic type relay (preferably gold contacts). This cannot be done on controls using some options. Consult your Dart Representative if options are involved.
- Q. Why is a jumper wire between AMP REF (P2-2) and REV 1 (P2-7) needed on drives with no options?**
A. REV 1 (P2-7) and REV 2 (P2-8) are two identical stop inputs. One of these must be held low (to Amp Ref P2-2) for the control to run. If the drive has no options, this must be jumpered to satisfy the "OR" gate. This requirement is satisfied by some options. For these options, a connection must be made to these terminals. Instead of a jumper wire, the option is wired to these terminals. (See "Jumper Wire Selection").

BASIC MODEL SELECTION

<i>115/230 VAC INPUT 0-90/0-180 VDC OUTPUT 100/200 VDC FIELD</i>			
HP RANGE ¹	CHASSIS	RELAY CHASSIS	RELAY ENCLOSED
1/8 - 2.0	530BC	530BRC	530BRE
<i>115/230 VAC INPUT 0-90/0-180 VDC OUTPUT 100/200 VDC FIELD</i>			
HP RANGE ²	CHASSIS	RELAY CHASSIS	RELAY ENCLOSED
1.5 and 3.0	533BC	Not Available	Not Available

Notes:

- 1) 1/8 - 1.0 h.p. uses 115VAC input, 0-90VDC output and 100VDC field; 1/4 - 2.0 h.p. uses 230VAC input, 0-180VDC output and 200VDC field
- 2) 1.5 h.p. uses 115VAC input, 0-90VDC output and 100VDC field; 3.0 h.p. uses 230VAC input, 0-180VDC output and 200VDC field

CONTROL FEATURES

INPUT VOLTAGE SELECTION SWITCH - Switch **selectable** between 115 VAC and 230 VAC input.

MIN SPEED - (Minimum speed) Allows adjustment of the motor speed when the speedpot is set at minimum. This permits the user to eliminate the "Deadband" on the main speed control, permitting zero calibration. Clockwise rotation of the "MIN" trimpot increases output VDC.

ACCEL - (Acceleration) Allows adjustment of the motor acceleration from a minimum of 0.3 seconds to a maximum of 12 seconds. The -15A option extends the maximum acceleration time to 30 seconds.

DECEL - (Deceleration) Allows adjustment of the motor deceleration from a minimum of 0.6 seconds to a maximum of 12 seconds. The -15A option extends the maximum deceleration time to 30 seconds.

MAX SPEED - (Maximum speed) Allows adjustment of the motor speed when the speedpot is set at maximum (CW). This permits the user to eliminate the "DEADBAND" of the speedpot, providing full speed at maximum rotation. Rotation of the "MAX" trimpot in the clockwise direction increases maximum output VDC.

I.R. COMP - (Speed Regulation) Allows adjustment of the circuitry that controls the speed regulation of the motor. This feature controls armature speed by changing the armature voltage to compensate for increased or decreased motor loading. Clockwise rotation of the "I.R. COMP" trimpot will increase gain compensation.

CUR. LIM. - (Current Limit) Provides protection from excessive armature current by limiting the maximum armature current the control can provide. This enables adjustment of the maximum torque the motor can deliver. Set Current Limit (CUR. LIM.) at 125% of the rated motor current. Clockwise rotation of the "CUR. LIM." trimpot increases the torque (current) the control will provide.

TACH INPUT SELECTION - Factory set at 3V per 1000 RPM, jumper selectable (JU3) to 7V per 1000 RPM. Refer to "Tach Feedback" section in "Control Modifications" for more information.

TERMINAL STRIP P1 - Barrier type terminal strip provides for connection of AC lines, motor leads, motor field (if necessary), and earth ground.

TERMINAL STRIP P2 - Barrier type terminal strip provides for connection of speed potentiometer and any accessories and/or jumper wires which control the drive.

RELAY - (Power Interrupt Relay's) Available only on the "RC" and the "RE" versions, the relay's permits the switching of AC power with a low current signal. For the "RE" version, the relay's will not allow start up after power failure without manually restarting.

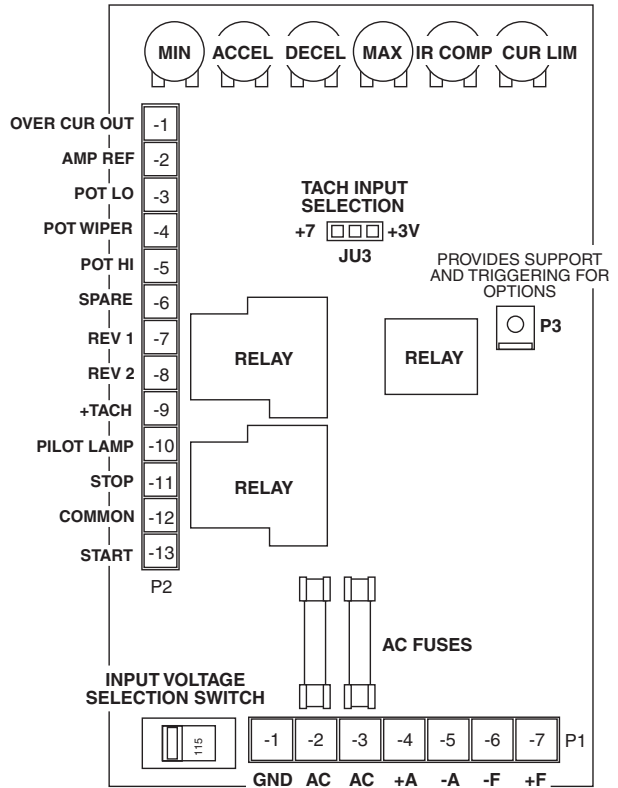

OVERALL CONTROL DIMENSIONS

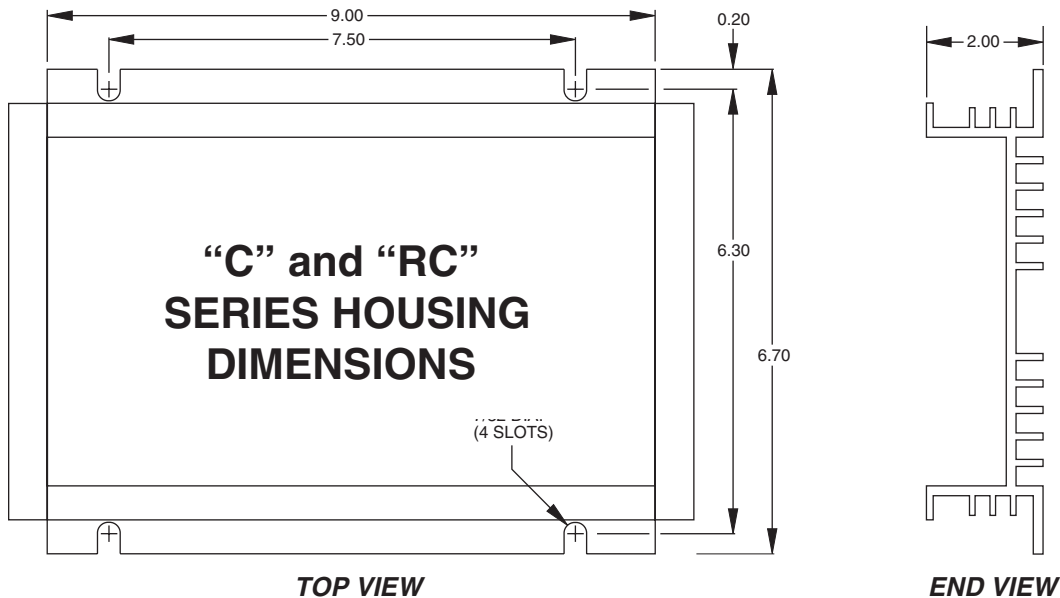

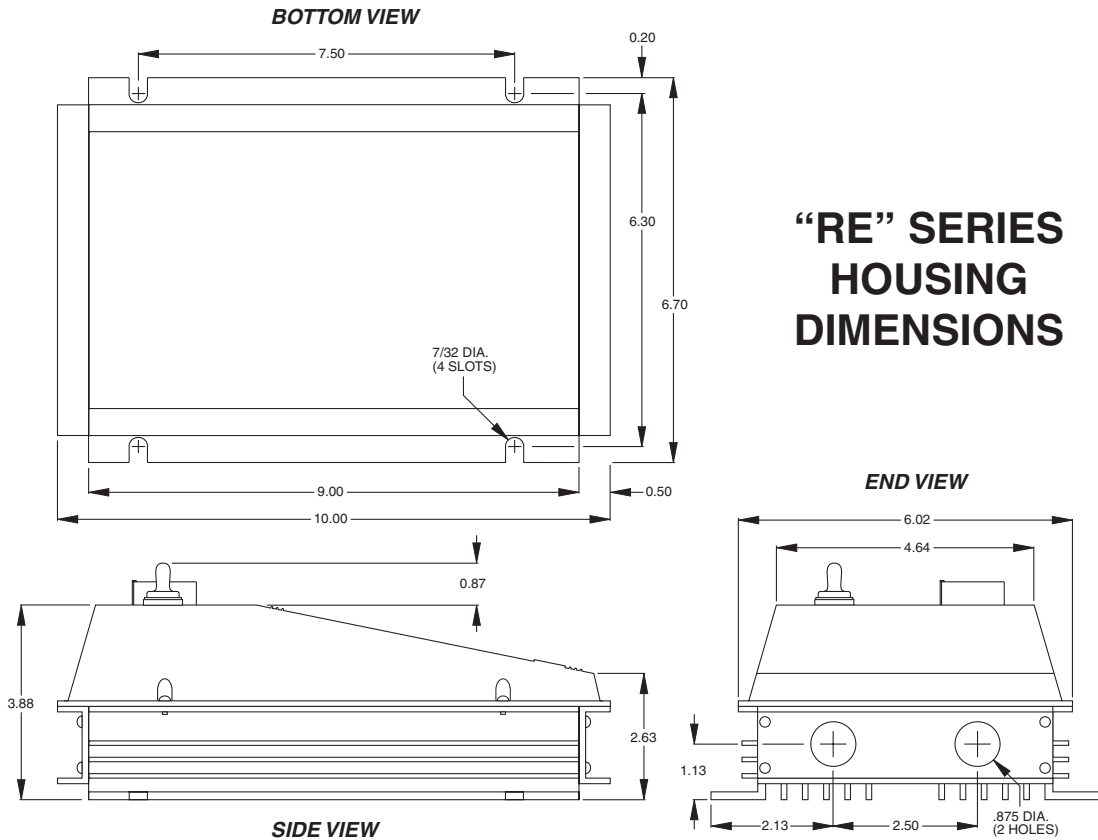

SPEEDPOT MOUNTING DIMENSIONS

(For “C” and “RC” versions)

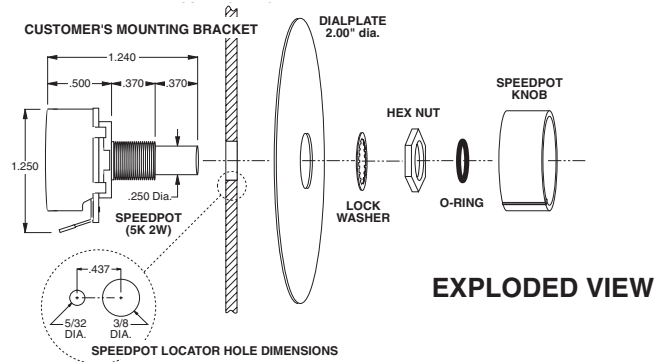

DO NOT MOUNT CONTROL WHERE AMBIENT TEMPERATURE IS OUTSIDE RANGE OF -10° to 45° C. (15° to 115° F.)

MOUNTING INSTRUCTIONS

1. Four 7/32" slots are provided for control mounting.
2. The 530B Series chassis can be used as a template.
3. Use standard hardware to mount.
4. For the “RE” version ONLY: Two 7/8" diameter holes are provided in one endplate to facilitate wiring. This allows for easy connection of 1/2" conduit.

NOTE: For enclosed models using 1 h.p. 90V or 2 h.p. 180V motors, the control MUST be mounted vertically.

CAUTION:

DO NOT ATTEMPT TO PERFORM HI-POT TEST ACROSS AC LINES WITH THE CONTROL IN CIRCUIT. THIS WILL RESULT IN IMMEDIATE OR LONG TERM DAMAGE TO THE CONTROL.

WIRING PROCEDURE

1. Size all wires which carry armature or line current to handle currents AS SPECIFIED BY NATIONAL, STATE, AND/OR LOCAL CODES. All other wires may be # 20AWG or smaller as permitted by local code.
2. Control wire (Pot, Tach, etc.) should be separated from all the Armature, Field (if Shunt Wound), and the AC wires when routed in conduits or in wire trays. The enclosed version has two holes on one endplate for this purpose.

TERMINAL STRIP WIRING - P1

CAUTION: BE SURE CONTROL HOUSING IS PROPERLY GROUNDED.

The 530B Series uses a 7 position barrier type terminal strip to handle the power connections.

- P1-1 (EARTH GROUND)** - Ground the control by connecting the ground wire to this terminal. NOTE: Terminals P1-5 (-ARM) and P2-2 (AMP REF) are electrically the same, which is the common reference point (low voltage common) for the control logic. The EARTH GROUND terminal (P1-1) is electrically different from common. If connected together, either at the amplifier or in any other fashion, fatal or hazardous operation may occur and permanent damage to the control WILL result!
- P1-2 (AC1) 115VAC** - Connect incoming hot AC (black wire) to this terminal. NOTE: This is fused (F1) on the control.
(AC1) 230VAC - Connect either hot side.
- P1-3 (AC2) 115VAC** - Connect the neutral AC (white wire) to this terminal. NOTE: This is fused (F2) on the control.
(AC2) 230VAC - Connect either hot side.
- P1-4 (+ ARMATURE)** - Connects to the plus (+) Armature wire on the motor. 0-90VDC for 115VAC input or 0-180VDC for 230 VAC input. See "SPECIFICATIONS" for output rating.

CAUTION: ARMATURE CONNECTION MUST NOT BE SWITCHED OR BROKEN WHILE CONTROL IS ON OR SERIOUS DAMAGE TO THE CONTROL MAY RESULT.

- P1-5 (- ARMATURE)** - Connects to minus (-) Armature wire (also considered circuit common) on the motor.
- P1-6 (- FIELD)** - Connect minus (-) Field wire of the Shunt Wound motor (not used on PM motors).

FIELD VOLTAGE TABLE		
Model #	VAC Input	VDC Field
530B Series	115	100
	230	200

- P1-7 (+ FIELD)** - DO NOT use for Permanent Magnet motor. This supplies + Field voltage for a Shunt Wound motor. See chart above for dual voltage Field Wound motors. This output is rated at 1 Amp for 530B series controls and 1.5 Amps for the 533B control. For motors with dual voltage field (ie. 50/100V or 100/200V), make sure the highest value is connected.

TERMINAL STRIP WIRING - P2

The 530B Series uses a 13 position barrier type terminal strip for control connections.

CAUTION: NONE OF THE P2 TERMINALS SHOULD BE EARTH GROUNDED!

- P2-1 (OVER CURRENT OUT)** - Can be used to signal that the control is in current limit. It can also signal other devices or alarms. This is a low level logic signal which goes "high" when the current limit amplifier is in current limit. The logic of this control is +12 volts, while the output at this terminal is approximately 1.5 volts through a 1000Ω resistor when in Current Limit.
- P2-2 (AMP REF)** - This is the common point of the logic. It is used as common with OVER CURRENT OUT (P2-1), +TACH (P2-9), REV 1 (P2-7), REV 2 (P2-8), and WIPER (P2-4). NOTE: Never connect this terminal to earth ground !! Serious damage and injury may result !! This terminal is electrically the same point as -ARM (P1-5).
- P2-3 (SPEEDPOT LO)** - Connects to the low side (orange wire) of the 5K Speedpot (normally the CCW end). This input is raised and lowered by the MIN trimpot. Electronic speed input voltage (voltage follower) may be referenced to Speedpot LO if the MIN trimpot adjustments are to be active. Otherwise, inputs may be referenced to AMP REF (P2-2), which will bypass the MIN trimpot. INPUT MUST NOT BE GROUNDED !

**CAUTION FOR VOLTAGE FOLLOWER APPLICATIONS:
THE INPUT CONNECTION TO THE SPEEDPOT MUST NOT BE GROUNDED !!
SERIOUS DAMAGE TO THE CONTROL MAY RESULT FROM A GROUNDED INPUT.**

- P2-4 (SPEEDPOT WIPER)** - Connects to the wiper (red wire) of the Speedpot (center lead). Use this input for the plus (+) side of voltage follower operation or tach follower. The minus (-) side connects to AMP REF (P2-2). INPUT MUST NOT BE GREATER THAN +12V MAXIMUM AND MUST NOT BE GROUNDED !
- P2-5 (SPEEDPOT HI)** - Connects to high side (white wire) of the Speedpot (CW end). This is internal +12 volts. INPUT MUST NOT BE GROUNDED !
- P2-6 (SPARE)** - This terminal is not connected to the control circuit. It can be used as a terminal for field modifications.

(P2 wiring continued)

P2-7 (REV 1) - REV 1 and REV 2 are identical quick stop inputs. One of them must be held low (to AMP REF) before the control will operate. The two are diode separated to form an "OR" gate. Since -ARM (P1-5) is also low in the system, these two inputs can be wired to the motor side of a reversing switch or relay. During the period of switching, neither input will be low, which will instantly return the set speed to zero and reset the acceleration ramp.

P2-8 (REV 2) - Identical to REV 1 (P2-7).

P2-9 (+TACH) - Connect +Tach from a DC tachometer for tachometer feedback. The minus (-) lead from the tachometer goes to AMP REF (P2-2). Output voltage from the tachometer at full speed can range from 6 to 12 volts. The scale is corrected using the JU3 jumper selectable setting of 3V/7V per 1000 RPM and the MAX speed trimpot. A 3 volt per 1000 RPM OR 7 volt per 1000 RPM tachometer should be used.

P2-10 (PILOT LIGHT) - Connecting point for on-off neon indicator lamp. The remaining lead will be connected to P2-11.

P2-11 (STOP) - Install one or more normally closed stop switches (in series) between STOP (P2-11) and COMMON (P2-12). Not active on "C" version.

P2-12 (COMMON) - Mid point of Start-Stop switches. Not active on "C" version.

P2-13 (START) - Install one or more normally open start switches (in parallel) between START (P2-13) and COMMON (P2-12). Not active on "C" version.

SETTING INPUT VAC

For use with 110 through 130 VAC inputs, slide 115/230 VAC input voltage selector switch completely to the left as shown below left. For use with 208 through 240 VAC inputs, slide the same selector switch completely to the right as shown below right.

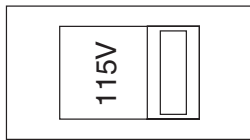

Note:
An incorrect setting of the input VAC selector switch will result in damage to the controller.

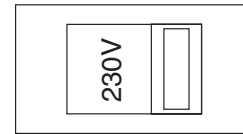

SWITCH LADDER CIRCUIT DIAGRAMS



START-STOP WIRING

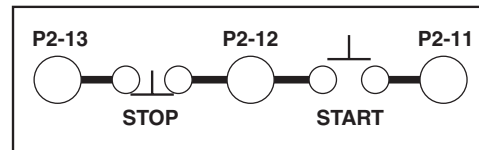

START-STOP WIRING (WITH 3 STATIONS)

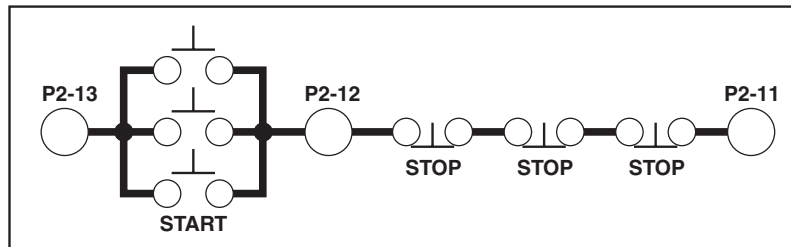

Warning:
This diagram is for "RC" and "RE" versions ONLY! DO NOT use on "C" version.

"RE" CONTROL PANEL IDENTIFICATION

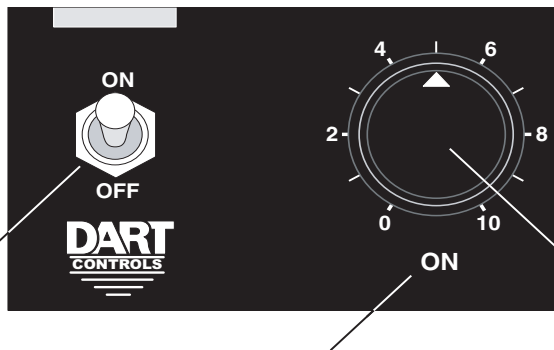

START-STOP SWITCH
MOMENTARY SWITCH TURNS CONTROL ON AND OFF

POWER ON INDICATOR
HIDDEN LED INDICATOR LAMP

SPEED POTENTIOMETER
5000& 2W SPEEDPOT
CONTROLS MOTOR SPEED

INITIAL START UP

1. **Check** to see that the **115/230 VAC selection switch is set for the desired input voltage.**
2. Recheck all wiring. Accidental grounds, loose or pinched wires on armature or speed potentiometer wires may damage the control when power is applied.
3. See "ADJUSTMENT PROCEDURE" and observe the WARNINGS pertaining to cover removal for adjustments.
4. Preset trimpots for your horsepower by using the "TRIMPOT CHART". NOTE: Options may change the trimpot setting from this chart. If your control has an option, be sure to carefully read the section in "OPTIONS" that pertains to your option.
5. Turn speed potentiometer to zero (fully CCW).
6. Turn power on and advance speedpot while observing motor.
7. If motor rotation is incorrect, turn power off at external disconnect and reverse the +ARM and -ARM connections.
8. If operation is satisfactory, no re-adjustments are needed.
9. If instability or surging is observed, or if maximum speed is higher than desired, proceed to "ADJUSTMENT PROCEDURE".
10. For other problems, see section "IN CASE OF DIFFICULTY".

WARNING:

WHEN MAKING AN ADJUSTMENT, ALWAYS USE A SCREWDRIVER WITH AN INSULATED SHAFT TO AVOID THE SHORT CIRCUITING OF PC BOARD COMPONENTS. WHENEVER THE CONTROL COVER IS REMOVED, IT MUST BE SUPPORTED TO AVOID ACCIDENTAL CONTACT BETWEEN CONTROL CHASSIS AND LIVE COVER COMPONENTS.

TRIMPOT ADJUSTMENT PROCEDURE

Four adjustments (MIN., MAX., I.R. COMP., and CUR. LIM.) are checked at the factory using a typical motor. Use the "TRIMPOT CHART" to adjust the trimpots to the approximate setting for your horsepower. The other two adjustments (ACCEL and DECEL), are the Acceleration and Deceleration adjustments and should be set for your particular application requirements. The "TRIMPOT CHART" is approximate and is valid when using a speedpot or a 0 to 12VDC input signal to control the speed. Operation of the control beyond $\pm 10\%$ of normal line voltage is not recommended and could result in readjustments. These settings are permanent; periodic readjustment is normally not needed. (NOTE: Use only an ungrounded voltmeter).

MAX. Sets maximum motor speed when speedpot is at 100% CW rotation. Clockwise rotation increases maximum motor speed.

- 1) Connect a DC voltmeter; plus to +ARM and minus to -ARM.
- 2) Set meter voltage range for either 90 VDC or 180 VDC.
- 3) With no load on the motor, adjust the MAX trimpot to the rated armature voltage as seen on the meter.

NOTE: A tachometer or strobe may be used in place of a meter. Follow the above steps, but adjust the MAX trimpot to the rated motor base speed, indicated by tach or strobe.

MIN. Sets minimum motor voltage when Speedpot is set at zero. Clockwise rotation of the MIN. trimpot will increase the minimum motor voltage.

- 1) Set Speedpot to zero (fully CCW).
- 2) With no load on the motor, adjust the MIN trimpot clockwise until the motor starts to rotate.
- 3) Slowly back off the trimpot in the CCW direction until the motor stops.

NOTE: If motor rotation is desired at zero Speedpot setting, adjust the MIN trimpot clockwise until the desired minimum speed is reached.

I.R. COMP. Provides a means of improving speed regulation in the armature feedback mode. If a change in motor speed during a load change is of no concern, rotate this trimpot fully CCW.

- 1) Set speedpot at 50%.
- 2) Observe motor speed during a no load condition.
- 3) Apply a full load to the motor.
- 4) Adjust the I.R. COMP. trimpot clockwise (while the load is applied) until the no load motor speed is obtained.

CUR. LIM. Limits DC motor armature current (torque) to prevent damage to the motor or control. The current limit is set for 125% of the rated motor current. Clockwise rotation of this trimpot increases the armature current (or torque produced).

- 1) Turn drive power OFF!
- 2) Connect a DC Ammeter in series with the +ARM line (between +A on motor and +ARM on the control). Preset the current limit trimpot CCW.
- 3) Turn power on and set speedpot to 50%.
- 4) Increase the motor load until the motor stalls (zero RPM).
- 5) Set CUR. LIM. trimpot by adjusting CW to 125% of the rated motor armature current (see "TRIMPOT CHART").

ACCEL Allows adjustment of acceleration by user.

- 1) Clockwise trimpot rotation increases length of acceleration time needed for the control to reach full speed.

DECEL Allows adjustment of deceleration by user.

- 1) Clockwise trimpot rotation increases length of deceleration time needed for the control to reach zero speed.

TRIMPOT SETTING CHART

MIN	ACCEL	DECEL	MAX	I.R.	CUR LIM	HP	VOLTS	MIN	ACCEL	DECEL	MAX	I.R.	CUR LIM	HP	VOLTS
						1/8	115							1/4	230
						1/6	115							1/3	230
						1/4	115							1/2	230
						1/3	115							3/4	230
						1/2	115							1.0	230
						3/4	115							1.5	230
						1.0	115							2.0	230
						1.5	115							3.0	230

NOTES: These settings apply when using a 5000Ω speedpot. This chart cannot be used with certain Options (refer to Option section)

1.5 and 3.0 HORSEPOWER - MODEL 533BC

For 1.5 and 3.0 horsepower applications, the model 533BC control has the following restrictions:

- Available in chassis (C) mount only.
- The 1.5 horsepower model is available in 115 VAC input at 0-90 VDC out, while the 3.0 horsepower model is available in 230 VAC input at 0-180 VDC out.
- Relay, start-stop, reversing, dynamic braking & jogging are not available from factory (they are customer supplied and wired).
- The isolation boards (-5 and -7 options) are available.

BASIC HOOK-UP DIAGRAMS WITHOUT OPTIONS

(If options are included on your control, see the option section of this manual).

Model 530BC and 533BC ("C Version")

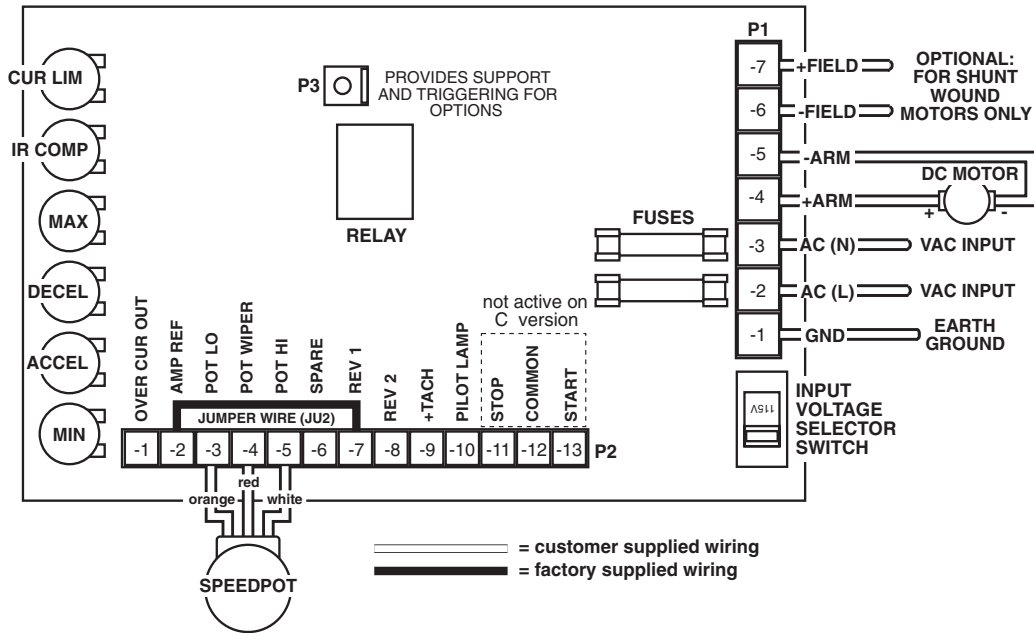

Model 530BRC ("RC Version")

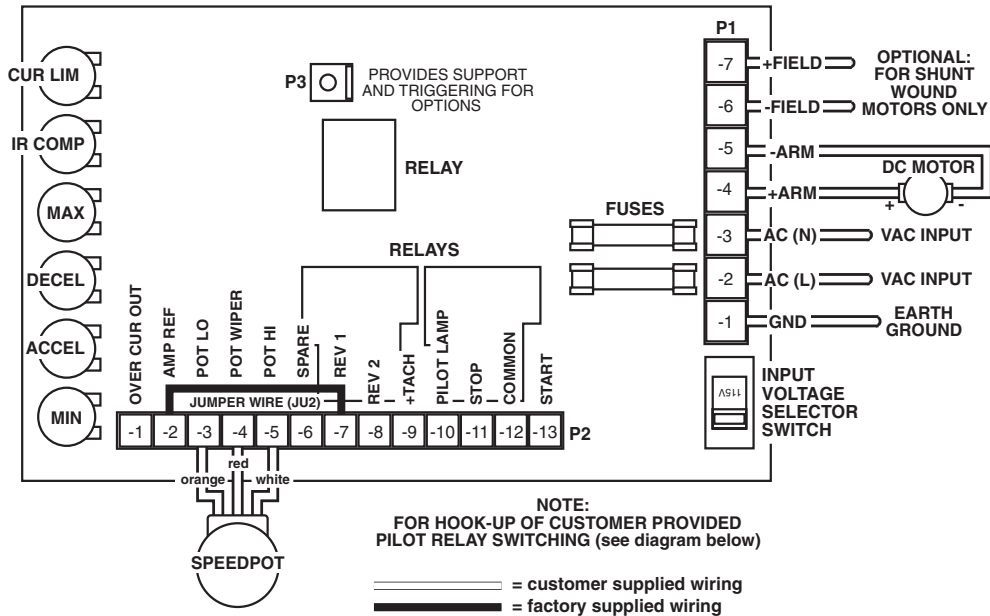

PILOT RELAY SWITCHING

(Customer supplied wiring for the "530BRC" version)

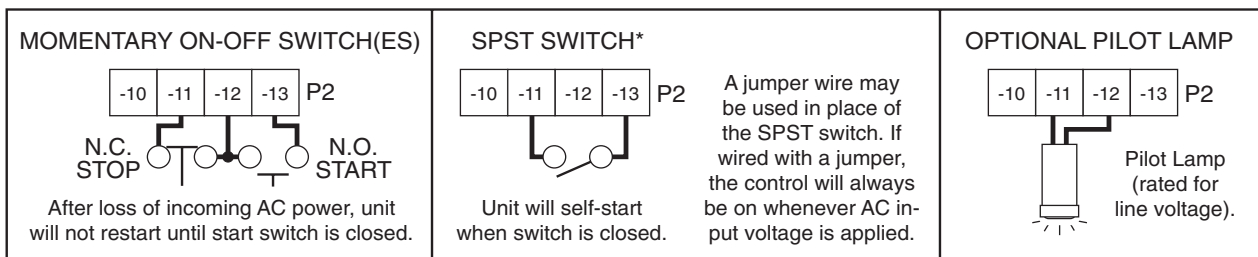

Model 530BRE ("RE Version")

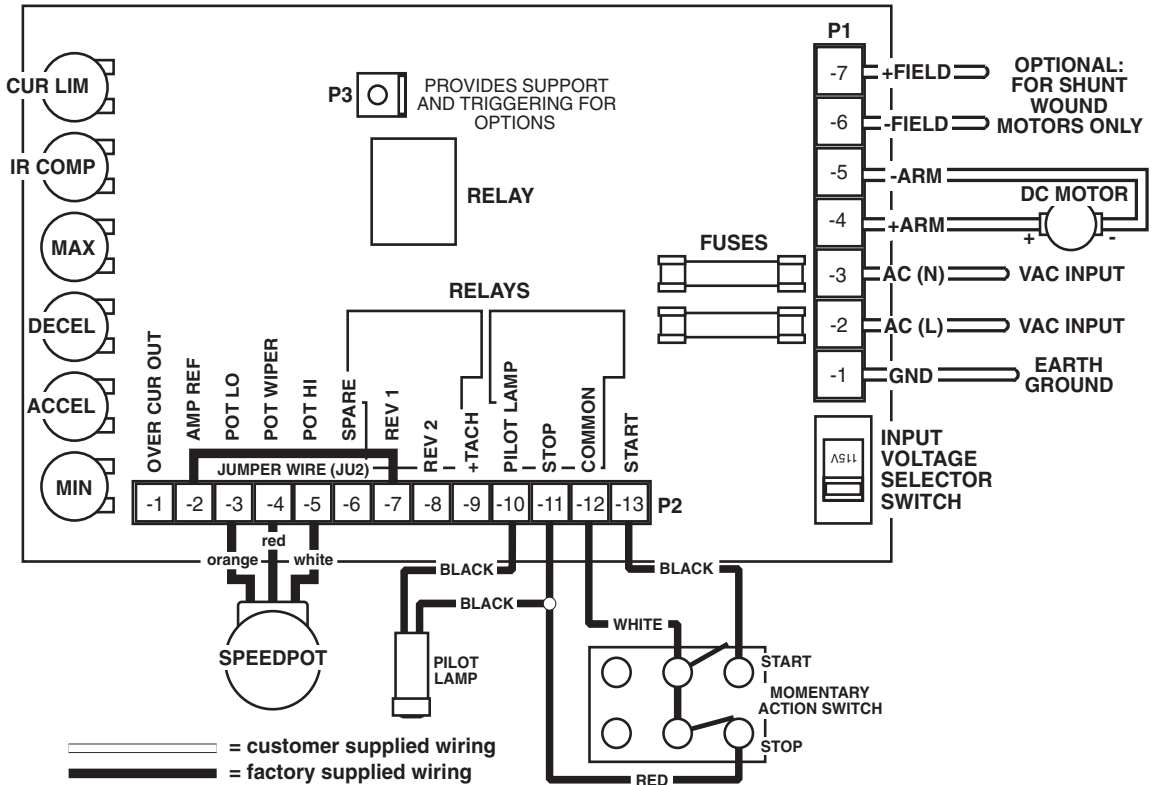

JU2 JUMPER WIRE SELECTION CHART

NOTE: Jumper wires may be required on terminal strip P2 for the control to operate (refer to jumper chart below).

As explained in the "COMMONLY ASKED QUESTIONS" section, REV 1 (P2-7) and REV 2 (P2-8) are both stop inputs. One of these inputs must be held low to AMP REF (P2-2) for the control to operate. Jumpering is necessary between AMP REF and REV 1 or REV 2 to satisfy the "OR" gate. An option board may be installed on the control satisfying the "OR" gate. This jumper (between P2-2 and P2-7) is called JU2. For inhibiting with soft start and fast stop, the JU2 jumper may be replaced by a SPST switch.

YES = JUMPER REQUIRED

NO = JUMPER NOT USED

OPTION	DESCRIPTION	PAGE #	JUMPER	"C"	"RC"	"RE"
NONE	STOCK CONTROL	9-10	JU2	YES	YES	YES
-4	JOG	11	JU2	YES	YES	YES
-5/-7	CURRENT FOLLOWER	12-13	JU2	YES	YES	YES
-36M/-38M	FWD / REV with ZERO SPEED and D.B.R.	14-15	JU2	NO	NO	NO

NOTE: Installing JU2 jumper when not required may cause permanent damage to control.

CONTROL MODIFICATIONS

TWO SPEED OPERATION

Two pot operation is done using two 10KΩ speed potentiometers in parallel (both HI's to P2-5, both LO's to P2-3). The WIPER is switched using a SPDT switch.

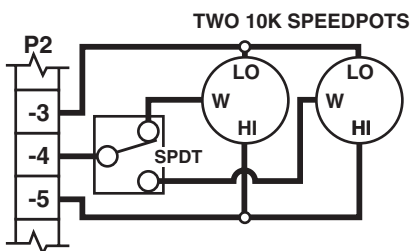

DYNAMIC BRAKING

A DPDT switch is used to inhibit the control and to connect the DBR. Typical values for the DBR (dynamic brake resistor) are 5 for 115V, 10 for 230V (both 35Ω to 50Ω). Note that motor horsepower, inertia, and cycle time effect sizing of the DBR.

NOTE: On -15A Option, Decel must be fully CCW to use with DBR.

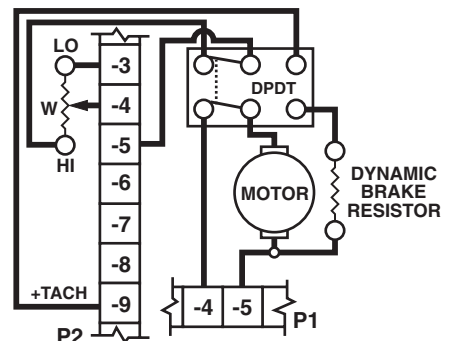

TACHOMETER FEEDBACK

Improves speed regulation to $-1/2\%$ of base speed.

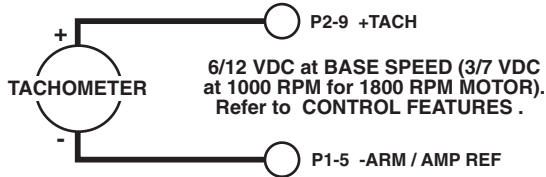

NOTE: NEED 1% OR LESS - TACH OUTPUT RIPPLE

TACHOMETER FOLLOWER

Allows control output to follow tachometer voltage.

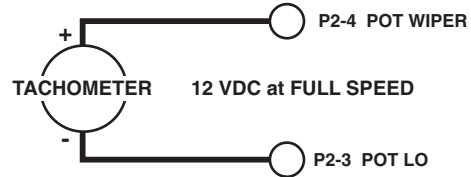

INHIBIT (USED INDEPENDENTLY)

The customer supplied SPST switch is connected in series between the speedpot HI (P2-5) and the +TACH terminal (P2-9). To inhibit, speedpot HI is closed to the +TACH terminal. To restart, the switch is returned to open. NOTE: The control will stop and start fast.

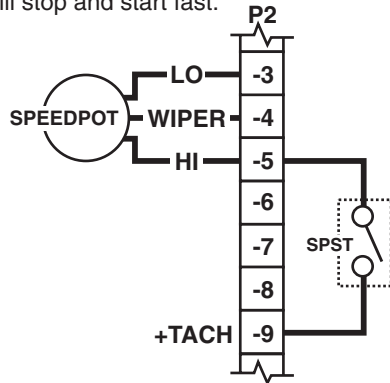

NOTE: Permits starting and stopping of motor without breaking AC lines. In the event of SCR failure or false triggering, the inhibit circuit will not stop motor.

INHIBIT (USED WITH SPEEDPOT)

The customer supplied SPST switch is connected in series between the speedpot HI terminal (P2-5) and speedpot HI. To inhibit, the SPST switch contacts are opened. To restart, the switch is returned to the closed position. NOTE: The control will soft stop and soft start through the acceleration setting.

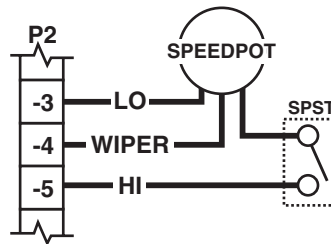

Always use a shielded wire when connecting to the inhibit terminal. The shield should be connected to the -Armature or Common of the control.

OPTIONS

NOTE: All options are specified by a suffix to the model number. This suffix starts with a dash (-). The more popular options are described on the following pages. When a combination of two or more of these options are used, the wiring procedure is beyond the scope of this manual. Please contact your Distributor or Representative.

-4 Option Jog

See below for installation and availability

This option is factory installed on the "RE" version only. "S2" is located on the cover and disables the latch circuit of the power relay's, allowing the power switch to jog the drive. The "C" and "RC" versions use customer supplied switch and wiring, in addition the "C" version uses a customer supplied relay.

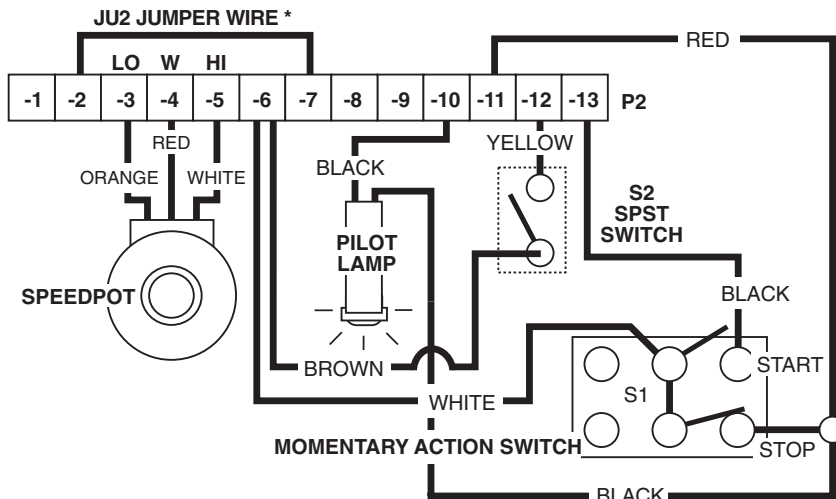

NOTES:

For "RE" version, S1, S2 and pilot lamp are FACTORY PROVIDED.

For "C" and "RC" versions, S1, S2, and pilot lamp are CUSTOMER PROVIDED.

* This jumper wire is not used with some other options. Consult factory if more than one option is being wired. Using JU2 jumper when not required may cause permanent damage to the control.

-5 Option
Isolated 4-20 ma.Signal Follower

*Available on "C" and "RC" models only**
Factory or Field installed

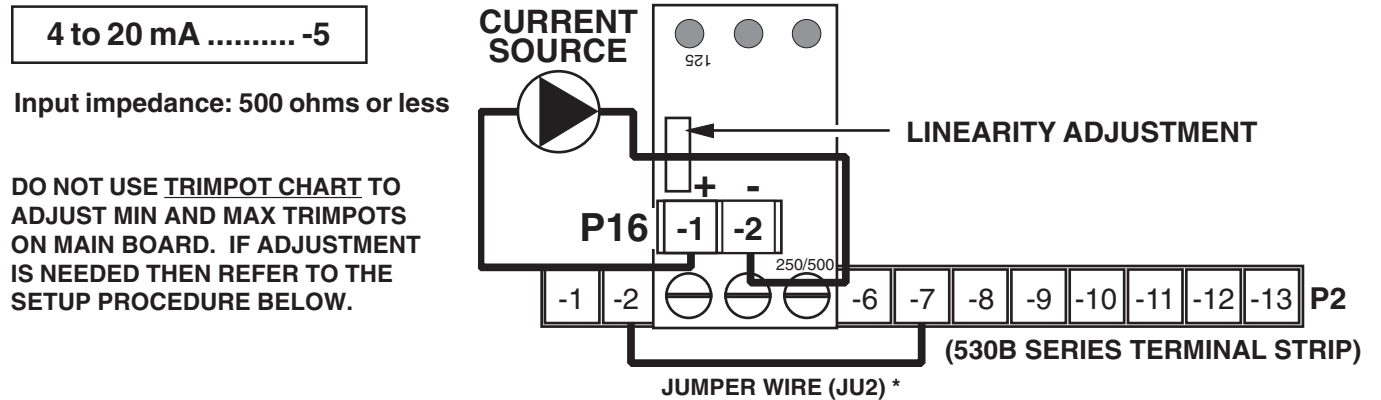

This option replaces the speedpot with a 4-20 ma. signal to control speed. The current signal input can be either grounded or ungrounded. The board sets on spacers screwed to terminals P1-3, P1-4, and P1-5 on the main board using long screws. The current source connects to the + and - two position terminal strip (P16-1 and -2) on the -5 option board.

The Linearity trimpot on the -5 option board is set at the factory for proper linearity, however this trimpot may need to be re-set after tuning the controls Max and Min trimpot settings for your specific application. If needed then refer to the setup procedure below.

Setting the Min, Max and Linearity Trimpots.

1. Preset the multi-turn Linearity trimpot on the -5 option board full CW, set the Min trimpot full CCW and set the Max trimpot at about 50% rotation.
2. Input a 4 ma. current signal to the control and turn the Min trimpot CW to your desired minimum output voltage or to deadband (the point just before you begin to get an output).
3. Input a 20 ma. current signal to the control and set the Max trimpot to the desired maximum speed setting.
4. With 20 ma. still going to the control, turn the Linearity trimpot CCW until your output speed starts to decrease. Then slowly turn it back CW until you just reach your maximum speed setting.

For enclosed models use -7 option.

*** Note:** This jumper wire is not used with some options. Consult factory if more than one option is being wired. Using the JU2 jumper wire when not required may cause permanent damage to the control.

-7 Option
Isolated 4-20 ma. Signal Follower
with Auto / Manual Switch

Factory or Field installed Chassis unit
Factory only on Enclosed models
Available on all models

Input impedance equals 500Ω or less

DO NOT USE TRIMPOT CHART TO ADJUST MIN AND MAX TRIMPOTS ON MAIN BOARD. IF ADJUSTMENT IS NEEDED THEN REFER TO THE SETUP PROCEDURE BELOW.

This option allows the control to be run in either the Manual mode via a speed pot or the Auto mode via the 4-20 ma. signal. The current signal input can be either grounded or ungrounded. The board sets on spacers screwed to terminals P1-3, P1-4, and P1-5 on the main board using long screws. The current source connects to the + and - two position terminal strip (P16-1 and -2) on the -7 option board.

This option includes a Balance trimpot which is used to scale the maximum speed in the manual mode. It is factory set so the maximum speed in manual equals the maximum speed in automatic.

The Linearity trimpot on the -7 option board is set at the factory for proper linearity, however this trimpot may need to be re-set after tuning the Max and Min trimpot settings on the control or if the Balance trimpot on the -7 must be reset for your specific application. If needed then refer to the setup procedure below.

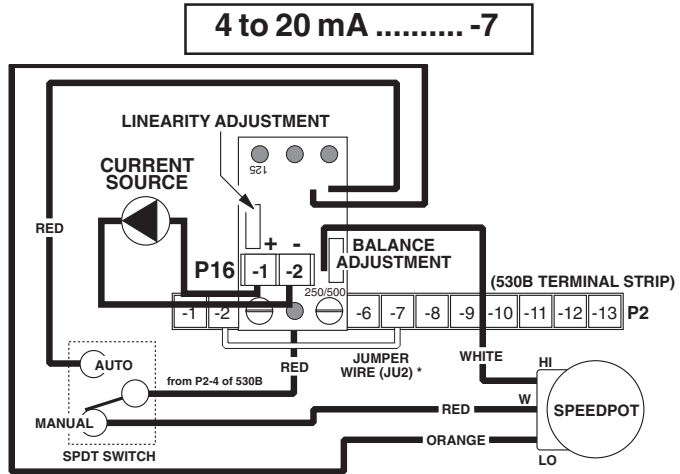

Setting the Min, Max, Balance and Linearity Trimpots.

1. Preset the multi-turn Linearity trimpot and the Balance trimpot on the -7 option board full CW, set the Min trimpot full CCW and set the Max trimpot at about 50% rotation.
2. Input a 4 ma. current signal to the control and turn the Min trimpot CW to your desired minimum output voltage or to deadband (the point just before you begin to get an output).
3. Input a 20 ma. current signal to the control and set the Max trimpot to the desired maximum speed setting.
4. Switch the control to the Manual mode setting and adjust the Balance trimpot CCW as needed to attain your required manual mode maximum output speed. (Adjustable from 50 to 100% of maximum Auto mode setting)
5. Switch the control back to Auto mode. With 20 ma. still going to the control, turn the Linearity trimpot CCW until your output speed starts to decrease. Then slowly turn it back CW until you just reach your maximum speed setting.

*** Note:** This jumper wire is not used with some options. Consult factory if more than one option is being wired. Using the JU2 jumper wire when not required may cause permanent damage to the control.

-11 Option
Ten Turn Speedpot

Field installed - ordered as separate item
Available on "C" and "RC" models only

Provides for a finer control of speed. Installation is the same as the standard speedpot.

-15A Option
Extended Accel / Decel

Factory installed
Available on all models

Extends acceleration / deceleration to 30 seconds (linear ramp).

-36M / -38M Option

Forward / Reverse with Zero Speed
Detect and Dynamic Brake

Factory or Field installed - see below
Available on all models except 3 H.P.

Option	AC Input	Installed	DBR Value	DBR location / placement
-36M	115VAC	factory or field	5Ω 30W	option board mounted
-36MA	115VAC	factory only	5Ω 50W	extrusion mounted
-38M	230VAC	factory or field	10Ω 30W	option board mounted
-38MA	230VAC	factory only	10Ω 50W	extrusion mounted

Warning: The addition of this option no longer allows for dual voltage operation of the 530B series board. The 115/230 VAC input selector switch (530B series board) must be set for the proper VAC input rating of the -36M/-38M option being used.

-36M / -38M HOOK-UP USING SPDT SWITCH OR CONTACT

NOTE:
INPUTS TO TERMINAL STRIP P5 CANNOT BE REFERENCED TO EARTH GROUND!

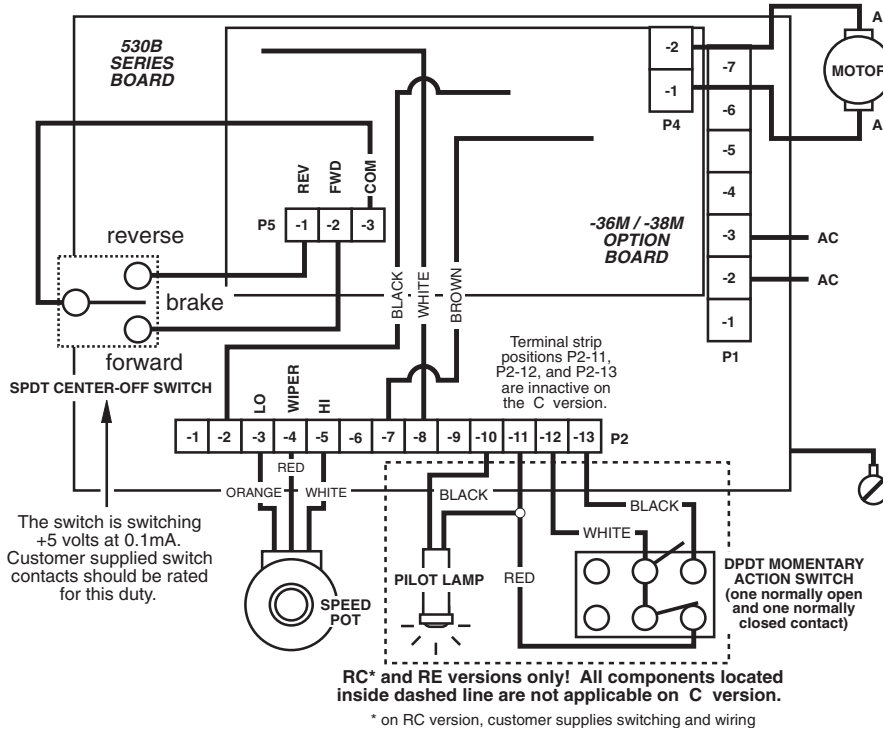

The -36M / -38M option automatically "brakes" to zero speed before reversing. The SPDT center-off switch is used to select direction. When the direction is reversed, relays K1, K2, and K3 connect the dynamic brake resistor to the armature. The motor "brakes" and at zero speed the relays reverse the armature leads, causing the motor to rotate in the opposite direction. When the switch is in the center (STOP) position, the motor armature is connected to the dynamic brake resistor.

Notes: The start-stop switch is customer provided on the "RC" version (see Hook-up Diagrams for switch wiring). The "RE" version requires a special cover that must be ordered for field installed -36M or -38M options. The Dynamic Brake Resistor is mounted accordingly per model (see above chart for placement).

VERY IMPORTANT:
DO NOT USE JU2 JUMPER WIRE with this option. WHEN RETROFITTING, JU2 JUMPER MUST BE REMOVED!!

To identify JU2 jumper location, see "Basic Hook-up Diagrams Without Options".

-36M / -38M HOOK-UP FOR NPN OPEN COLLECTOR DIRECTIONAL CONTROL

NOTE:
INPUTS TO TERMINAL STRIP P5 CANNOT BE REFERENCED TO EARTH GROUND!

Warning:
The addition of this option no longer allows for dual voltage operation of the 530B series board. The 115/230 VAC input selector switch (530B series board) must be set for the proper VAC input rating of the -36M/-38M option being used.

TRANSISTOR "A" ON = FWD.
TRANSISTOR "B" ON = REV.
BOTH "A & B" OFF = DYNAMIC BRAKE
BOTH "A & B" ON = DISALLOWED STATE
(CUSTOMER SUPPLIED LOGIC = A & B)

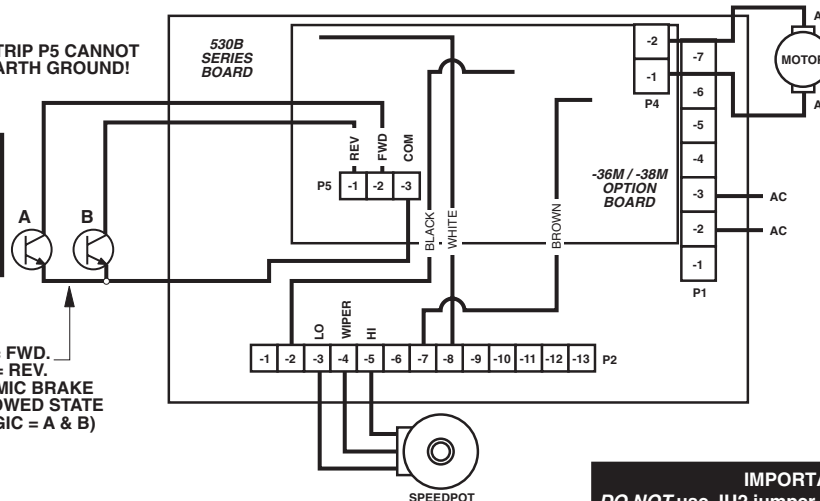

To identify JU2 jumper location, see "Basic Hook-up Diagrams Without Options".

IMPORTANT:
DO NOT use JU2 jumper wire with this option. When retrofitting, JU2 must be removed.

-36M / -38M HOOK-UP FOR UNIDIRECTIONAL RUN / DYNAMIC BRAKE

NOTE:
INPUTS TO TERMINAL STRIP P5 CANNOT BE REFERENCED TO EARTH GROUND!

Warning:
The addition of this option no longer allows for dual voltage operation of the 530B series board. The 115/230 VAC input selector switch (530B series board) must be set for the proper VAC input rating of the -36M/-38M option being used.

IMPORTANT:
DO NOT use JU2 jumper wire with this option. When retrofitting, JU2 must be removed.

To identify JU2 jumper location, see "Basic Hook-up Diagrams Without Options".

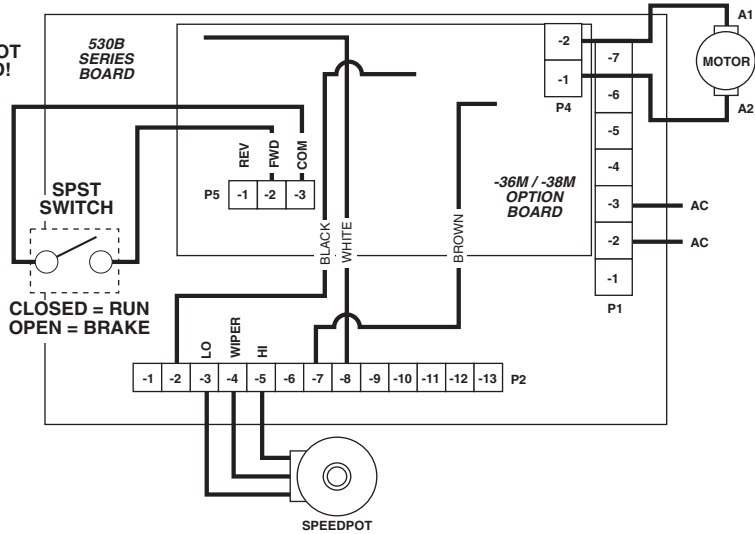

IN CASE OF DIFFICULTY

PROBLEM	POSSIBLE CAUSE(S)	CORRECTIVE ACTION(S)
Motor doesn't operate	Blown fuse Incorrect or no power source Speedpot set at zero Worn motor brushes Improper or missing jumpers	Replace fuse Install proper service Adjust speedpot CW to start Replace motor brushes See "JU2 Jumper Wire Selection Chart"
Armature output voltage cannot be adjusted, output is a constant DC level	No motor or load connected Speedpot low connection open	Check that the motor or load is connected to Armature terminals Check that speedpot low wire is connected
Motor stalls or runs very slowly with speed control turned fully CW	Low voltage Overload condition Worn motor brushes Max. speed set incorrectly	Should be above 104V or 208V Reduce load or re-adjust Current Limit Replace motor brushes See "Adjustment Procedure"
Motor hunts	Too much IR Comp Motor is in Current Limit Motor speed is above rated speed	See "Adjustment Procedure" See "Adjustment Procedure" Reduce Max trimpot setting
Repeated fuse blowing	Overload condition Worn motor brushes Defective motor Failed electrical components	Reduce load Relace motor brushes Replace motor Return for repair
Motor runs but will not stop	Incorrect wiring Defective wiring Failed component	Check "Terminal Strip Wiring" sections Check wiring Return for repair

After using this section, if control will still not operate, consult your Dart Distributor or Representative or return unit for repair.

FUSING

The motor and control are protected against overloads by the current limit circuit. Additional protection is provided through 2 fuses, which are mounted on the main board. Use exact fuse replacements if the fuse requires changing. Before changing fuses, be sure the power to the control is disconnected at the power source. Note: Both sides of VAC input are fused.

HP: 1/8 - 2.0 H.P.	FUSE SIZE: 20 Amp	FUSE TYPE: Bussman ABC-20 or Little Fuse 314020
HP: 3.0 H.P.	FUSE SIZE: 20 Amp	FUSE TYPE: Bussman ABC-20 or Little Fuse 314020

SPECIFICATIONS

AC INPUT VOLTAGE ±10% of rated line voltage
 ALTITUDE Up to 7,500 feet above sea level
 CONTROL OVERLOAD CAPACITY 200% for 1 minute
 DIMENSIONS & WEIGHTS:

	WIDTH	LENGTH	DEPTH	WEIGHT	TYPE
ENGLISH	6.70"	9.00"	2.25"	40 oz.	C
	6.70"	9.00"	2.25"	41 oz.	RC
	6.70"	10.00"	4.75"	56 oz.	RE
METRIC	171 mm	229 mm	51 mm	1134 gm.	C
	171 mm	229 mm	57 mm	1162 gm.	RC
	171 mm	254 mm	121 mm	1422 gm.	RE

DRIVE SERVICE FACTOR 1.0
 EFFICIENCY 85% typical
 ELECTRICAL SPECIFICATIONS - TYPICAL CURRENT & HORSEPOWER RANGES:

	115VAC INPUT / 0-90VDC OUTPUT		230VAC INPUT / 0-180VDC OUTPUT	
H.P.	MAX AC AMPS	MAX ARM AMPS	MAX AC AMPS	MAX ARM AMPS
1/8	1.80	1.40	-----	-----
1/6	2.60	2.10	-----	-----
1/4	3.50	2.70	1.80	1.40
1/3	4.40	3.40	2.20	1.70
1/2	6.50	5.00	3.30	2.50
3/4	9.30	7.20	4.80	3.70
1.0	13.20	10.20	6.50	5.00
1.5	21.50	14.70	9.70	7.50
2.0	-----	-----	12.90	9.90
3.0	-----	-----	22.00	15.00

FUSE PROTECTION 2 AC line fuses (see "Fusing")
 HUMIDITY 99% non-condensing
 INPUT FREQUENCY 50 or 60 Hertz
 MAXIMUM ARMATURE CURRENT - CONTINUOUS 10 ADC (2 H.P.); 15 ADC (3 H.P.)
 PILOT LAMP ("RE" VERSION) Neon
 POWER DEVICES Packaged full wave bridge
 SHUNT FIELD VOLTAGE 100VDC for 115VAC in; 200VDC for 230VAC in; (1.0 A max. - 530B; 1.5 A max. - 533B)
 SPEED CONTROL Via 5KΩ Potentiometer OR 0 to +10 VDC isolated signal
 SPEED RANGE 50:1
 SPEED REGULATION ±1% of base speed
 TACHOMETER FEEDBACK jumper selectable 3V or 7V per 1000 RPM
 TEMPERATURE RANGE -10° to 45° C. ambient (15° to 115° F.)
 TRANSIENT VOLTAGE PROTECTION G-Mov
 TRIMPOTS:

ACCELERATION RANGE 0.3 to 12 seconds - adjustable
 CURRENT LIMIT RANGE 1 to 20 Amps (1/8 to 2 H.P.)
 2 to 30 Amps (1.5 and 3 H.P.)
 DECELERATION RANGE 0.6 to 12 seconds - adjustable
 I.R. COMPENSATION RANGE 1/8 through 2.0 h.p. (530B controls)
 1.5 and 3.0 h.p. (533B control)
 MAXIMUM SPEED RANGE 60% to 120% of base speed
 MINIMUM SPEED RANGE 0 to 30% of maximum speed
 TYPE RAMP OF ACCEL / DECEL Linear

530B SERIES PARTS PLACEMENT & LIST

RESISTORS

R1	220K
R2	5K TRIM (MIN)
R3	47K
R4	300K
R5	10K
R6	4.7K
R7	250K TRIM (ACCEL)
R8	1K
R9	27K
R10	4.7K
R11	250K TRIM (DECEL)
R12	1K
R13	47K
R14	4.7K
R15	47Ω 1/2W
R16	91K 1/2W
R17	180K 1/2W
R18	470Ω
R19	47K
R20	6.8K
R21	300K
R22	1K
R23	47K
R24	470K
R25	10K
R26	680K
R27	22K
R28	2.2K
R29	1K
R30	220K
R31	390Ω
R32	390Ω
R33	39K
R34	1K TRIM (CUR)
R35	2.2K
R36	470Ω
R37	50K TRIM (MAX)
R38	100Ω TRIM (I.R.)
R39	.SEE BELOW
R40	100K
R41	SEE BELOW
R42	33K
R43	100K

ACTIVE DEVICES

Q1	2N4124
Q2	LM78L12 REG.
U1	LM358 IC
U2	LM324 IC
U3	3052 MOC
U4	L512F BRIDGE

CAPACITORS

C1	.01μF 63V
C2	1μF 50V N.P.
C3	.01μF 400V
C4	.01μF 400V
C5	.068μF 250VAC
C6	.01μF 400V
C7	.01μF 63V
C8	NOT USED
C9	.22μF 250V
C10	150μF 16V
C11	47μF 16V
C12	470μF 50V
C13	1μF 50V N.P.
C14	.1μF 63V

DIODES

D1	S6A4
D2	S6A4
D3	1N4005
D4	1N4005
D5	1N914B
D6	1N5233B
D7	1N914B
D8	1N5242B
D9	1N4005
D10	1N5233B
D11	1N4005
D12	1N4005
D13	1N914B
D14	1N4005
D15	1N4005
D16	1N4005

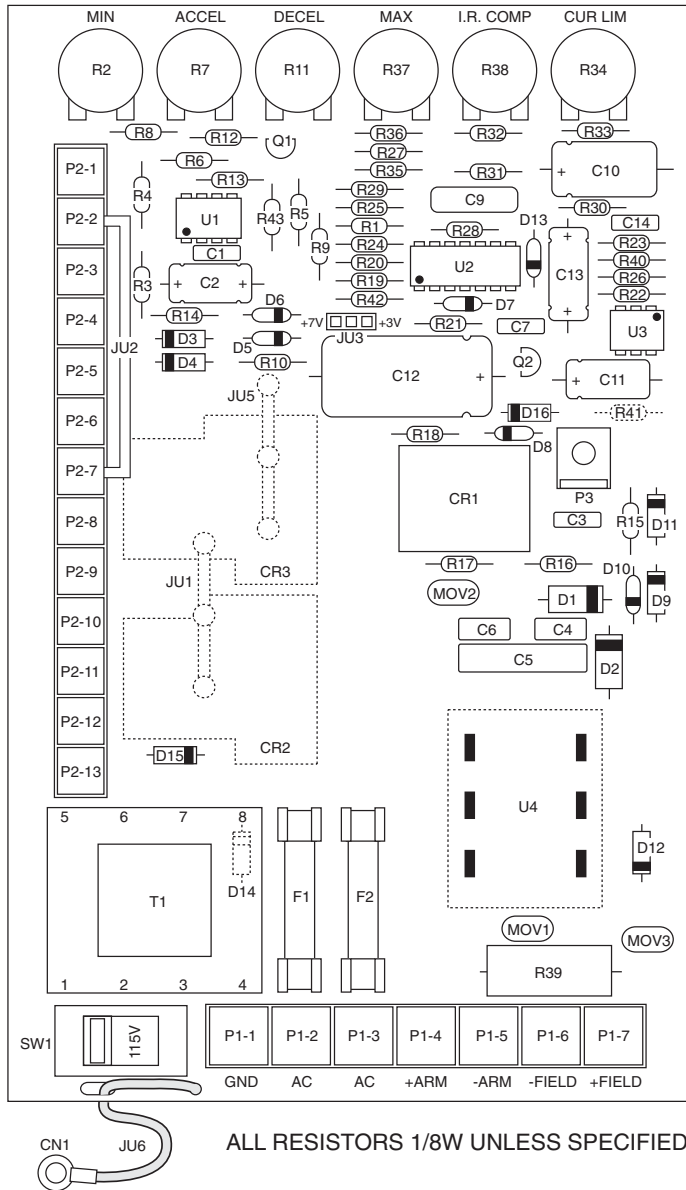

MISCELLANEOUS

CN1	CT60R16USB CONNECTOR	JU6	WC16GN3.5 WIRE
CR1	T73 RELAY	MOV1	275V G-MOV
CR2	SEE BELOW	MOV2	275V G-MOV
CR3	SEE BELOW	MOV3	275V G-MOV
F1	20A FUSE	PCB	A-4-2563C PRINTED CIRCUIT
F2	20A FUSE	P1	7 POS. TERMINAL STRIP
JU1	SEE BELOW	P2	13 POS. TERMINAL STRIP
JU2	WC16WH2.5SL JUMPER WIRE (SEE MANUAL "JUMPER WIRES")	P3	1/4" MALE SPADE PIN
JU3	3 POS. MALE CONN. W/JUMPER	SW1	115/230VAC SWITCH (DPDT)
JU5	SEE BELOW	T1	DST428 TRANSFORMER

-15A OPTION CHANGES

R13	180K
-----	------

530BC CHANGES:

CR2	NOT USED
CR3	NOT USED
JU1	RLB2503S RAIL
JU5	RLB2503S RAIL
R39	.015Ω 5W
R41	1K 1/2W

530BRC CHANGES:

CR2	T9A RELAY
CR3	T9A RELAY
JU1	NOT USED
JU5	NOT USED
R39	.015Ω 5W
R41	NOT USED

530BRE CHANGES:

CR2	T9A RELAY
CR3	T9A RELAY
JU1	NOT USED
JU5	NOT USED
R39	.015Ω 5W
R41	NOT USED

533BC CHANGES:

CR2	NOT USED
CR3	NOT USED
JU1	RLB2503S RAIL
JU5	RLB2503S RAIL
R39	.005Ω 5W
R41	1K 1/2W

530B SERIES SCHEMATIC

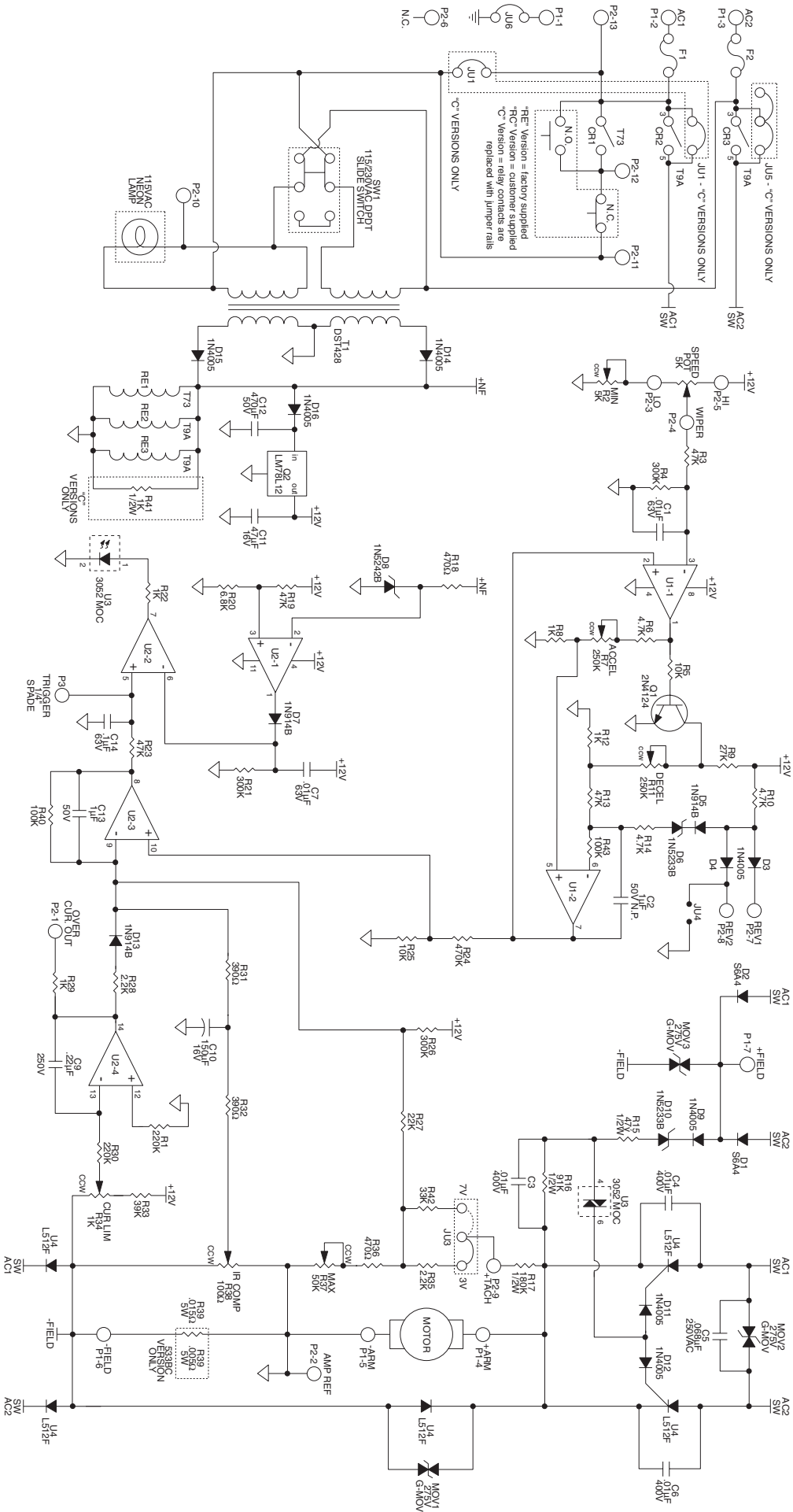

REPAIR PROCEDURE

In the event that a Product manufactured by Dart Controls Incorporated (DCI) is in need of repair service, it should be shipped, freight paid, to: Dart Controls, Inc., 5000 W. 106th Street, Zionsville, IN. 46077, ATTN: Repair Department.

Those orders received from anyone without an existing account with DCI will need to specify if they will be paying COD or Credit Card (Master Card or Visa). This information is required before work can begin. If you have an account with Dart your order will be processed according to the terms listed on your account.

Completed repairs are returned with a Repair Report that states the problem with the control and the possible cause. Repair orders are returned via UPS Ground unless other arrangements are made. If you have further questions regarding repair procedures, contact your Dart Controls, Inc. at 317-733-2133 Ext.460.

YOUR MOTOR SPEED CONTROL SOLUTIONS PROVIDER



125D SERIES
AC INPUT - VARIABLE DC OUTPUT
1/50 HP through 1.0 HP



250G SERIES
AC INPUT - VARIABLE DC OUTPUT
1/50 HP through 2.0 HP



65 SERIES
DC INPUT - VARIABLE DC OUTPUT
CURRENT RATINGS OF 20, 40, AND
60 AMPS



700/COMMUTROL SERIES
DC BRUSHLESS
5 & 20 Amp for
12,24,& 36VDC Inputs



MDP SERIES
PROGRAMMABLE
CLOSED LOOP DC
SPEED CONTROL



DM SERIES
FIELD PROGRAMMABLE
DIGITAL TACHOMETER

Dart Controls, Inc. is a designer, manufacturer, and marketer of analog and digital electronic variable speed drives, controls, and accessories for AC, DC, and DC brushless motor applications.

Shown above is just a sampling of the expanded line of Dart controls that feature the latest in electronic technology and engineering. Products are manufactured in the U.S.A. at our Zionsville (Indianapolis,

Indiana) production and headquarters facility - with over 2,000,000 variable speed units in the field.

In addition to the standard off-the-shelf products, you can select from a wide variety of options to customize controls for your specific application. For further information and application assistance, contact your local Dart sales representative, stocking distributor, or Dart Controls, Inc.

Dart Controls, Inc.

Manufacturer of high quality DC and AC motor speed controls and accessories since 1963.

P.O. Box 10
5000 W. 106th Street
Zionsville, Indiana 46077
Phone: (317) 733-2133
Fax: (317) 873-1105